

Instructions

For

630E-001A

Rotary Switch Mounting Plate

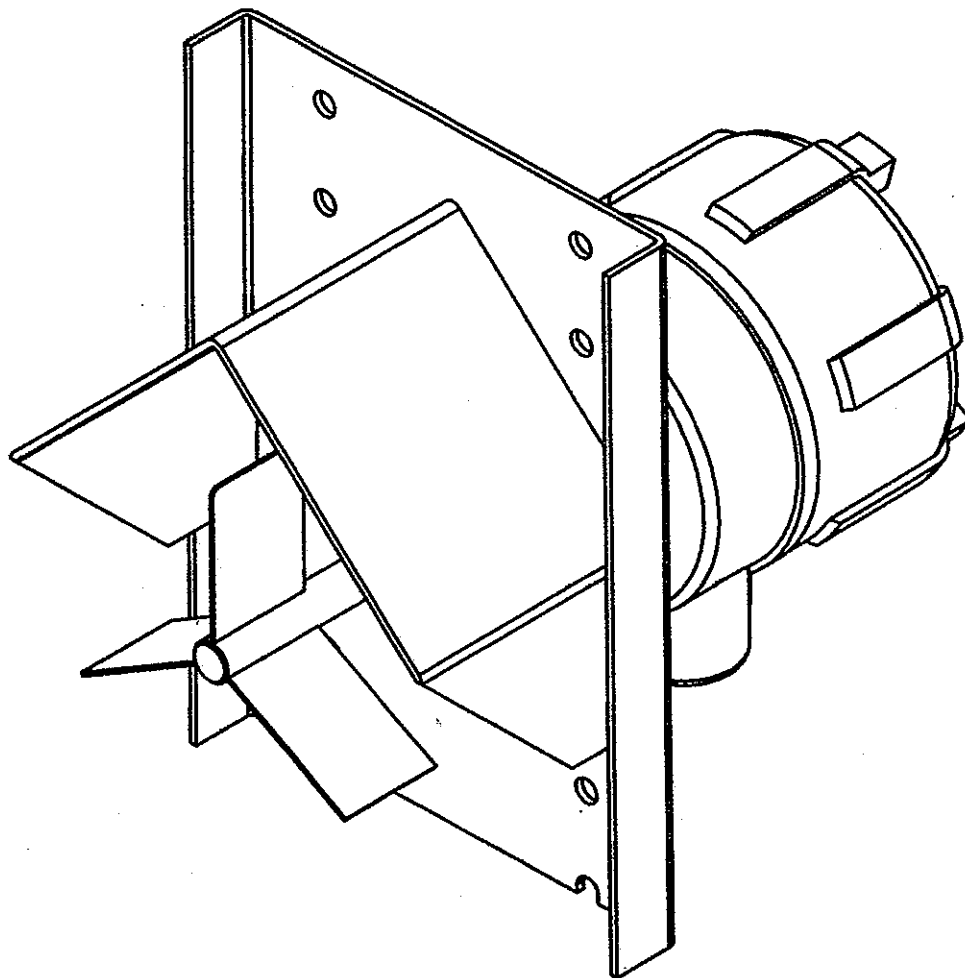

Shivers Manufacturing, Inc.
614 W. English St.
Corydon, IA 50060
Ph. (641) 872-1005 ** Fax (641) 872-1593
www.shivers.com

P-12523
2-24-09

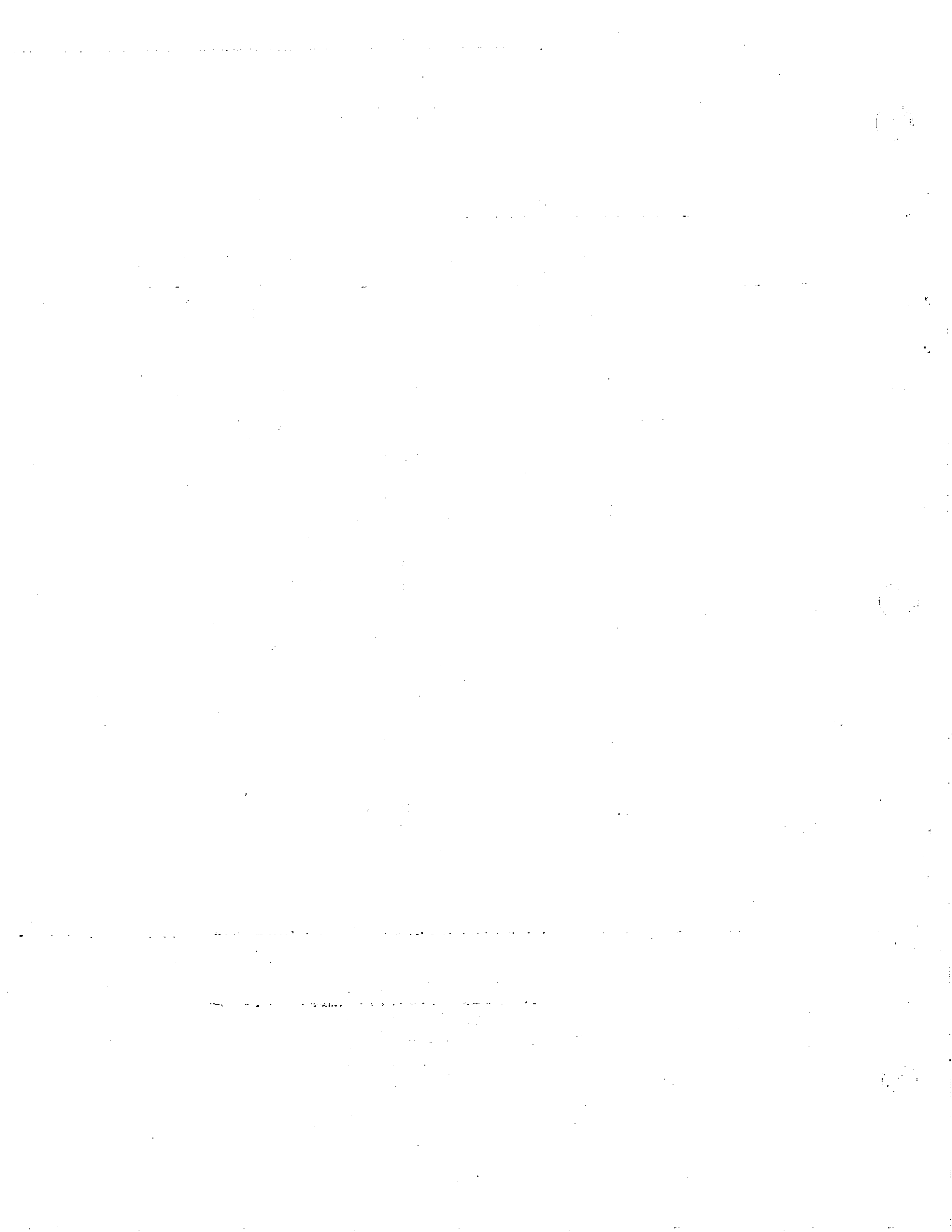

Introduction

The 630E-001A Rotary Switch Mounting Plate Kit is used to mount a rotary type paddle switch in a grain bin for level control. It is specifically designed to work for a Bin Master number BRMX-115VAC switch with a GRP-30 Paddle, available from Garner Industries (www.binmaster.com or 1-800-228-0275). Other rotary type switches may also work, but have not been tested.

Installation

- 1) Also refer to the instructions supplied with the rotary switch.
- 2) Hold the 630-025W Mounting Plate Weldment up to the bin wall at the approximate level desired. The plate mounts to the inside of the bin wall, so adjust it up or down so the corrugations line up with the mounting holes as shown.

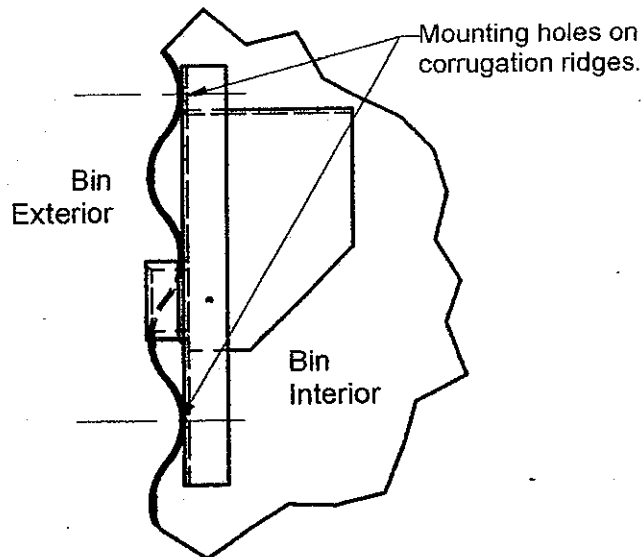
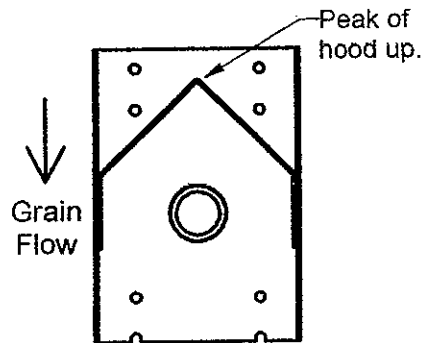

- 3) Mark the large center hole and cut an approximately 3" diameter hole in the bin sidewall.

- 4) Hold the mounting plate back up to the bin wall and mark and drill 4 mounting holes. Extra holes are provided in the mounting plate which will match up to a Shivers Low Grain Shut-Off or Grain Level Indicator, if one of those is being replaced.

5) Use sealant around the 3" hole and mount the plate to the bin wall. Bolts can either go in or out.

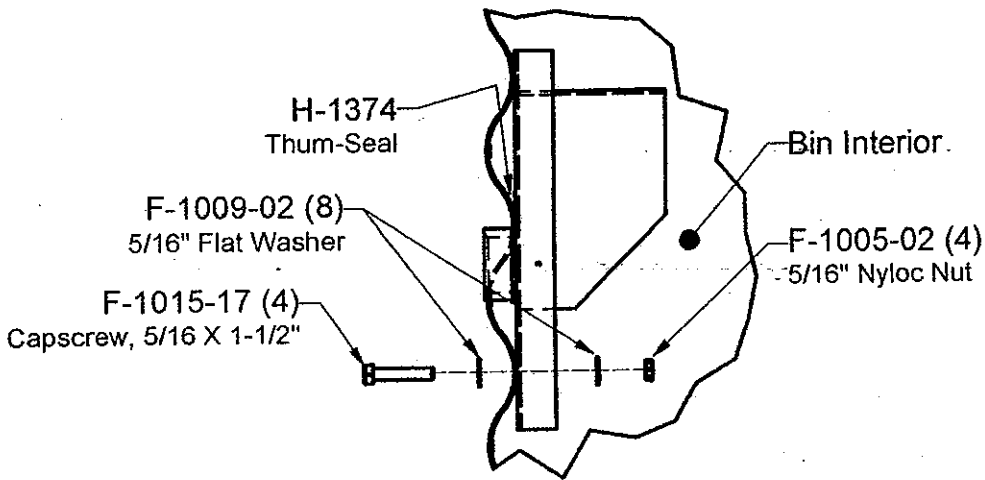

6) Apply anti-sieze to the threads of the rotary switch and screw it into the mounting plate. Make sure the conduit openings are down.

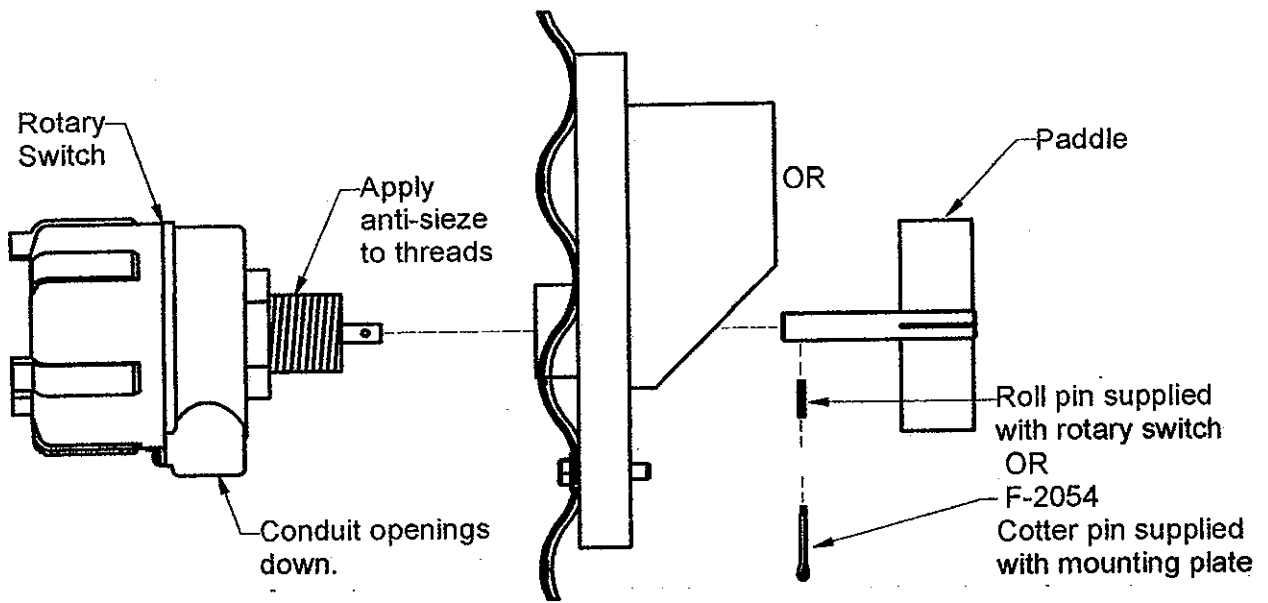

7) Install the paddle using either the roll pin or cotter pin supplied. If using the roll pin, start it into the paddle first, then when it is on the rotary switch shaft, use pliers to push it all the way through. Don't use a hammer, as this may damage the bearings in the rotary switch.

8) Loosen the cover holding screw on the rotary switch and unscrew the cover. Wire the rotary switch for your application. A couple of examples are given in the appendix.

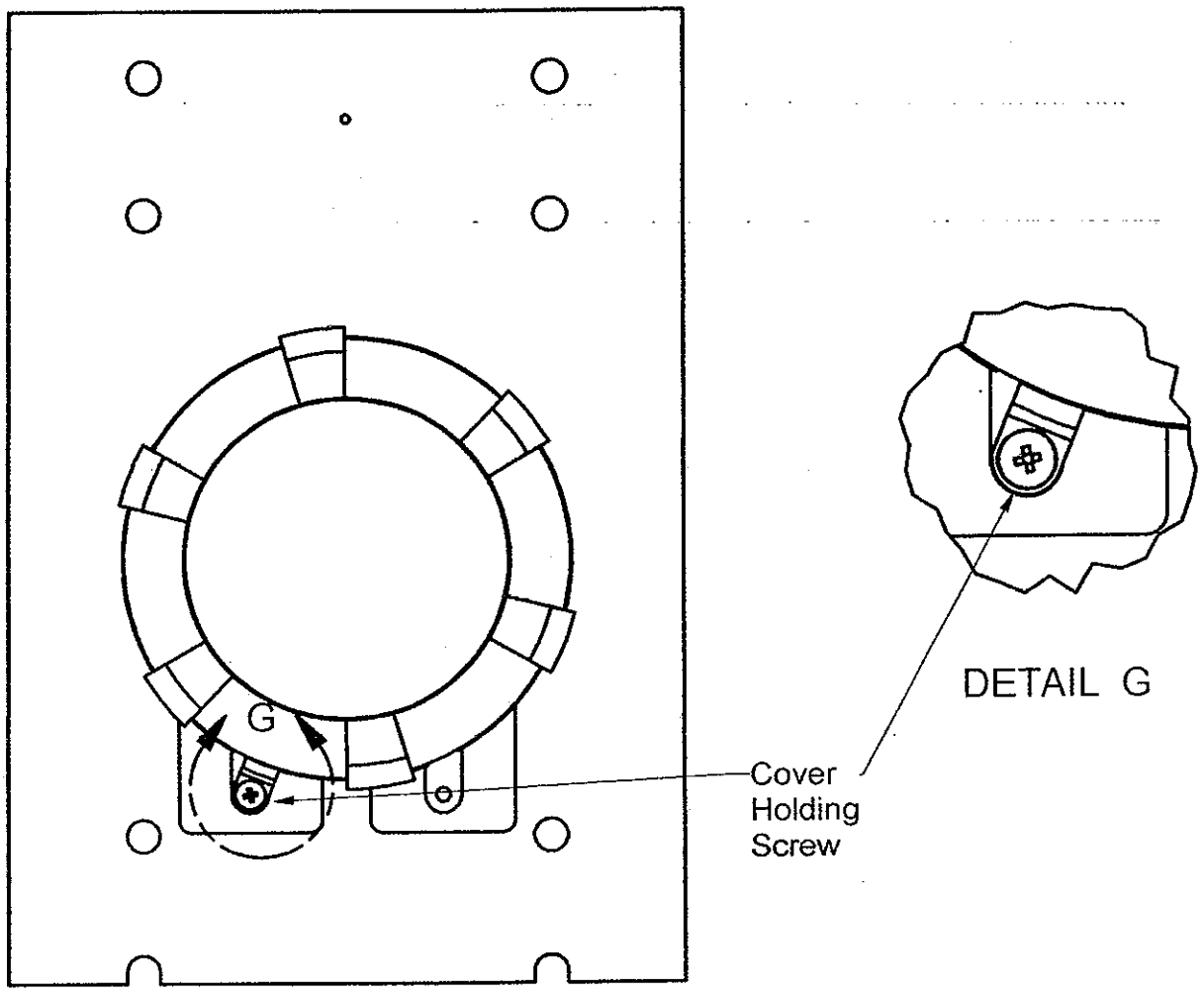

9) When wiring is complete, apply anti-sieze to cover threads and screw cover onto switch. Lock cover in place by tightening cover holding screw.

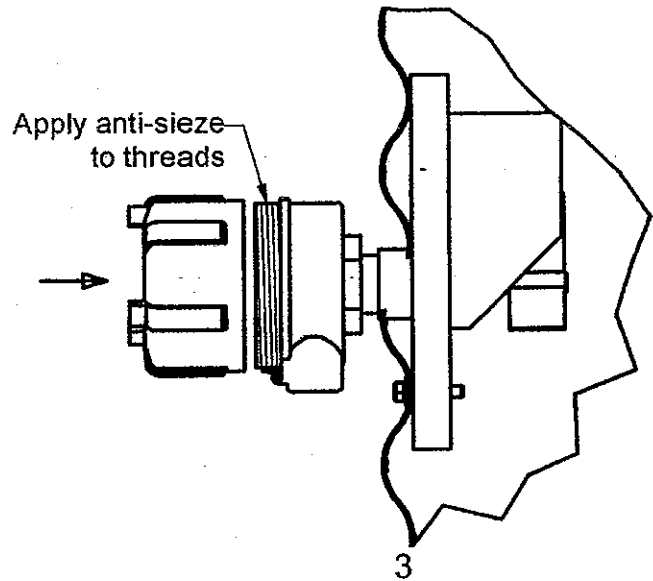

Appendix

For Shivers Low Level Grain Drying Control System, typical wiring for a BinMaster BMRX powered rotary switch is shown. This will work for either the high level or low level switch.

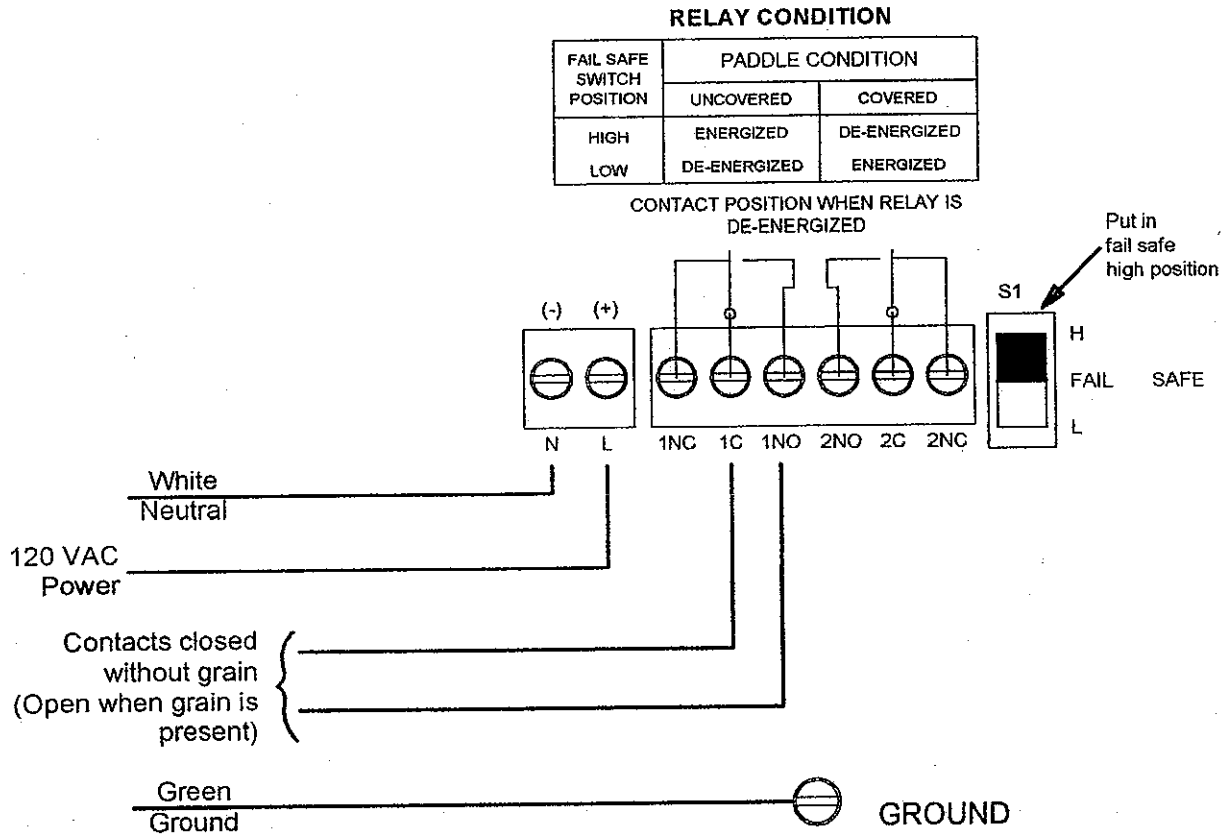

For replacement of Shivers Low Grain Shut-Off (LGSO) or Grain Level Indicator (GLI).

(For LGSO, neutral and ground wires will usually need to be supplied. A power wire may also need to be supplied, depending on the control panel.)

(For GLI replacement, a bypass switch, indicator light, and 3 pole relay will be required somewhere.)

