

DELUXE COMP-U-DRY Generation 2

By Shivers

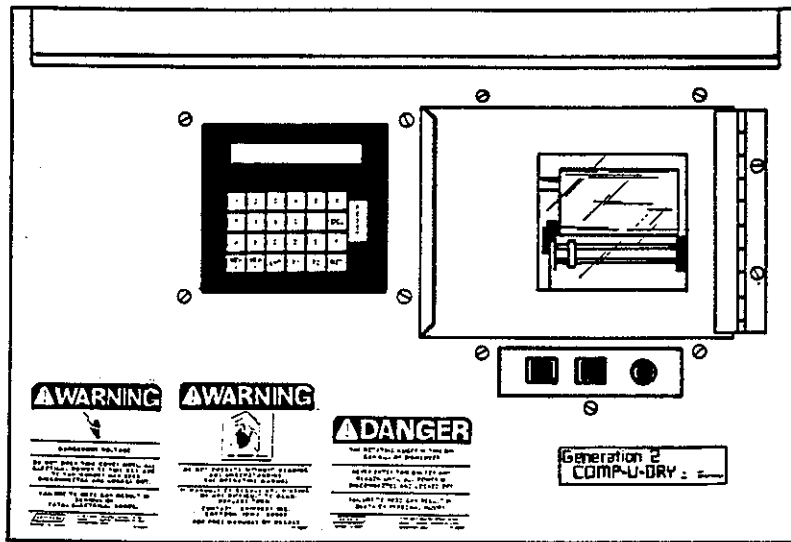

INSTALLATION INSTRUCTIONS AND WIRING CONNECTIONS

Shivers Incorporated
614 West English
Corydon, Iowa 50060
515/872-1005

P-10416
2/1/90

TABLE OF CONTENTS

	PAGE
NOMENCLATURE * * * * *	1-2
MECHANICAL INSTALLATION * * * * *	3-7
ELECTRICAL INSTALLATION * * * * *	8
10 POINT "I" TERMINAL EXPLANATION * * * * *	9
WIRING MOISTURE SENSOR * * * * *	10
WIRING PLENUM TEMPERATURE PROBE * * * * *	11
16 POINT "F" TERMINAL EXPLANATION * * * * *	12-13
SHIVVER'S FAN INTERRUPT * * * * *	14
SHIVVER'S UHP FAN INTERRUPT * * * * *	14
BLUE FLAME & BIG BLUE FAN INTERRUPT * * * * *	15
SHIVVER'S FAN INTERRUPT WITH HI-LIMIT CONTROL * * * * *	16
SHIVVER'S DELUXE CIRCU-TROL & BURNER TO COMP-U-DRY * * (models 295 & 74C)	17-19
SHIVVERS COMPACT CONTROL CENTER * * * * *	20-24
SHIVVER'S SMALL CIRCU-TROL (Model 296) & BURNER * * * (model 296)	25-27
SHIVVER'S 1974-77 CIRCU-TROLS * * * * *	28-33
NECO 230 CONTROL PANEL AND LOW GRAIN SHUTOFF * * * * *	34-37
GENERIC WIRING INSTRUCTIONS * * * * * (for all panels not specifically covered)	38-43

COMP-U-DRY CONTROL BOX

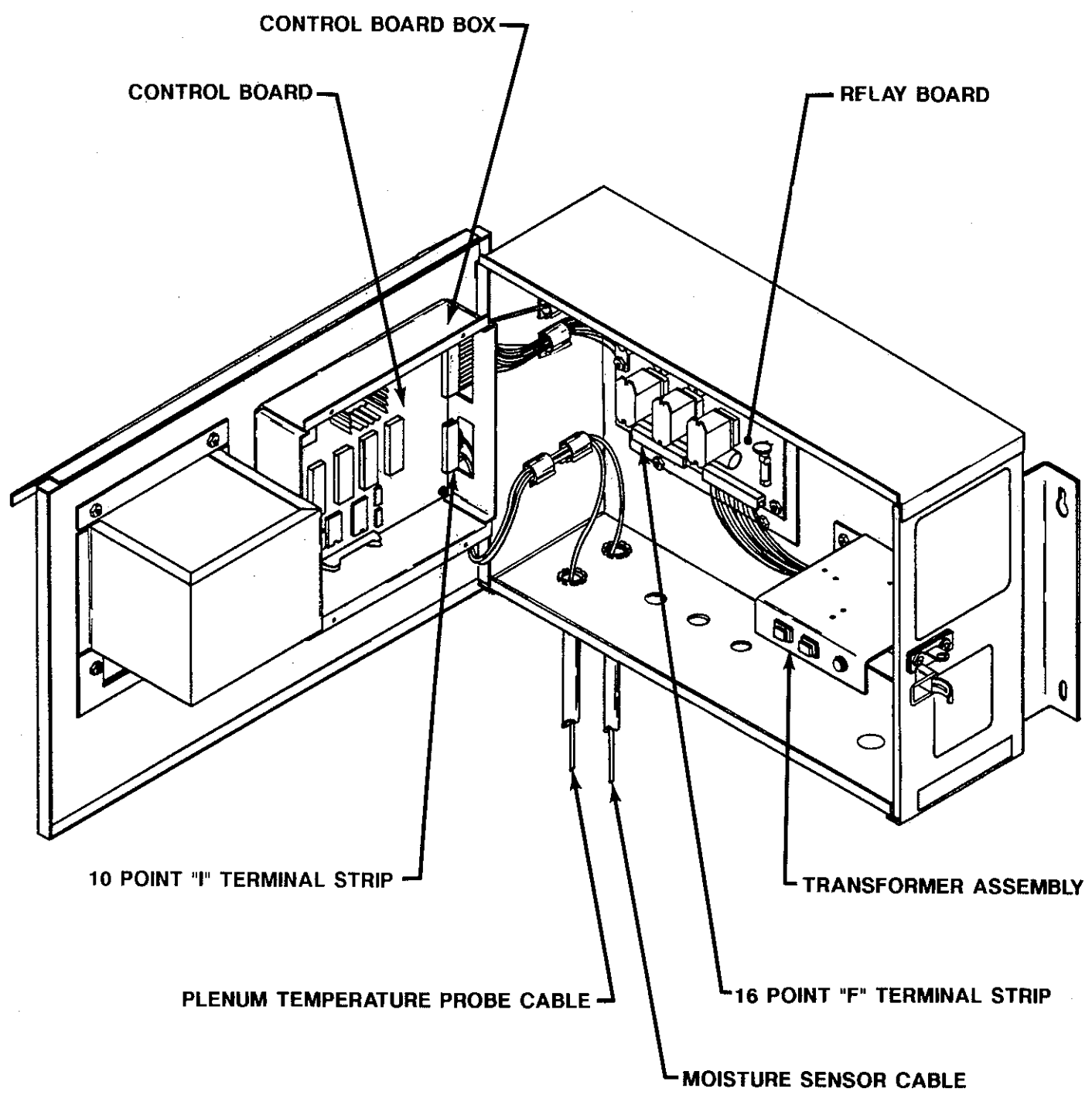

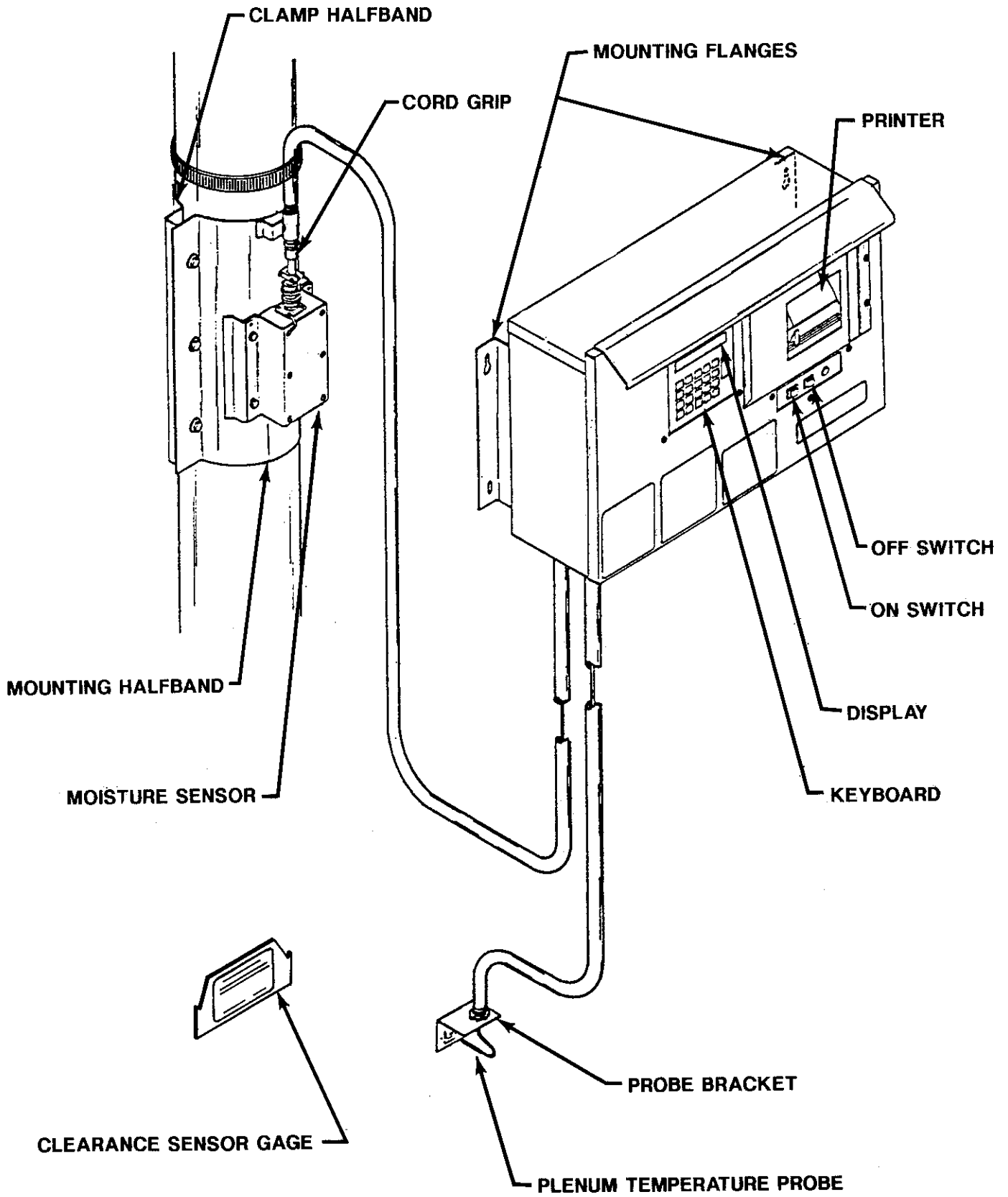

MECHANICAL INSTALLATION

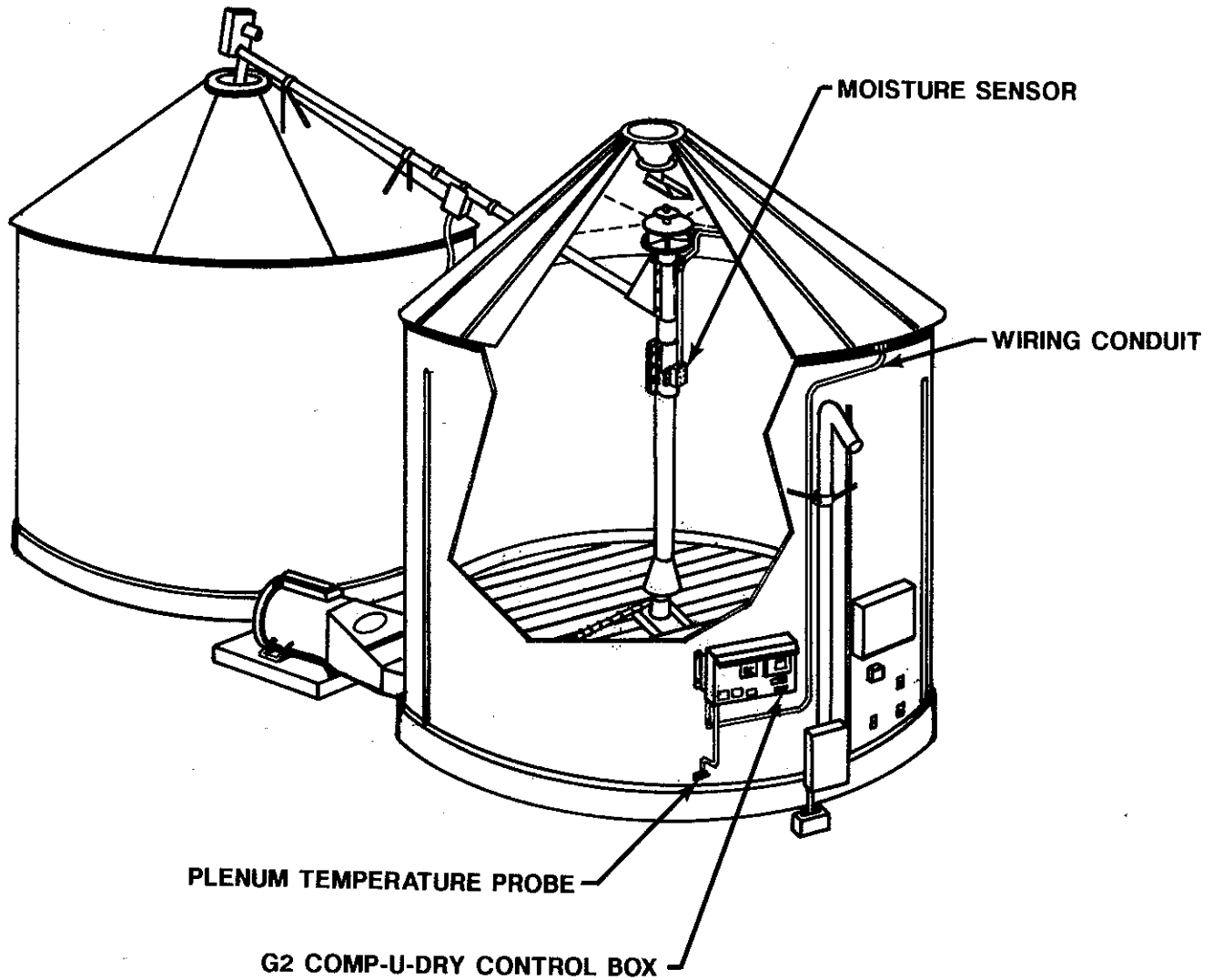

There are three units which need to be mounted on the drying system.

- 1) The G2 Comp-U-Dry Control Box.
- 2) The Moisture Sensor.
- 3) The Plenum Temperature Probe.

MECHANICAL INSTALLATION CONTROL BOX

While the 62 Comp-U-Dry Control Box is designed to be weather resistant and may be mounted on the bin sidewall, it is recommended that it be mounted in a building or enclosure near the drying bin for maximum life and minimum maintenance. Seventy five (75) feet of moisture sensor cable and fifteen (15) feet of temperature probe wire are provided with the unit. Extension kits are available if necessary.

The Comp-U-Dry Control Box will require a space approximately 30 inches wide for mounting. Mounting flanges are attached to the box.

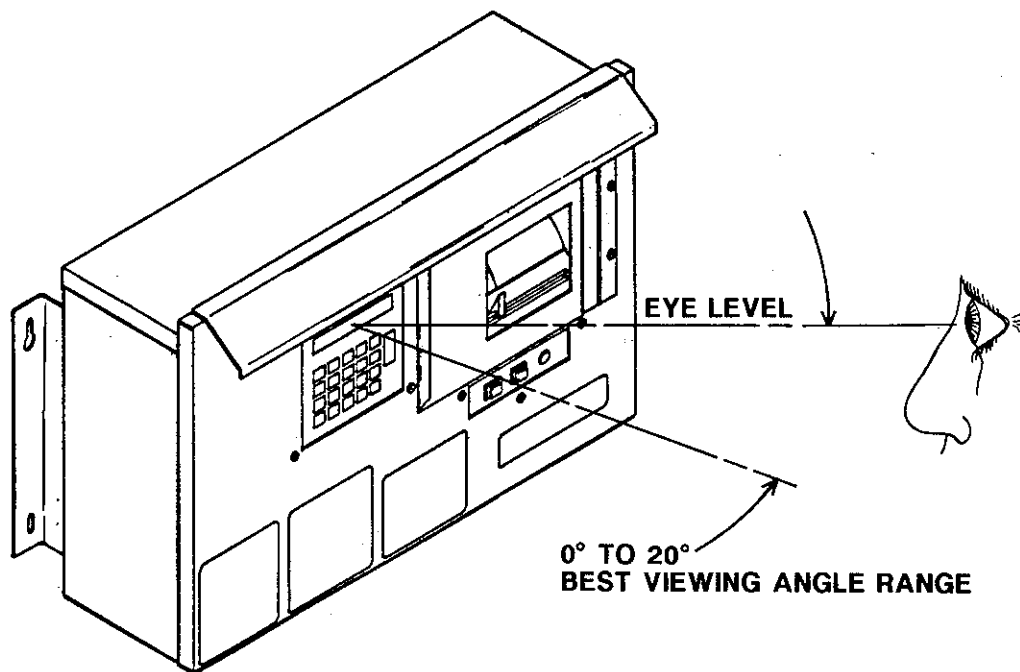

It is important that the Comp-U-Dry Control box be mounted with the display at or slightly above eye level. The display may be difficult to read if the viewing angle is downward.

MOUNTING THE MOISTURE SENSOR
!!! MAKE SURE ALL POWER IS DISCONNECTED !!!

For Circu-Lators, the Moisture Sensor should be mounted below the lowest boot on the center vertical. There must be sufficient room above the Moisture Sensor for the wire conduit.

On Dri-Flo type machines, the Moisture Sensor should be mounted on the bottom of the horizontal discharge tube rotated slightly towards the climb side of the auger. Be sure the moisture sensor is mounted in the proper direction for the grain flow.

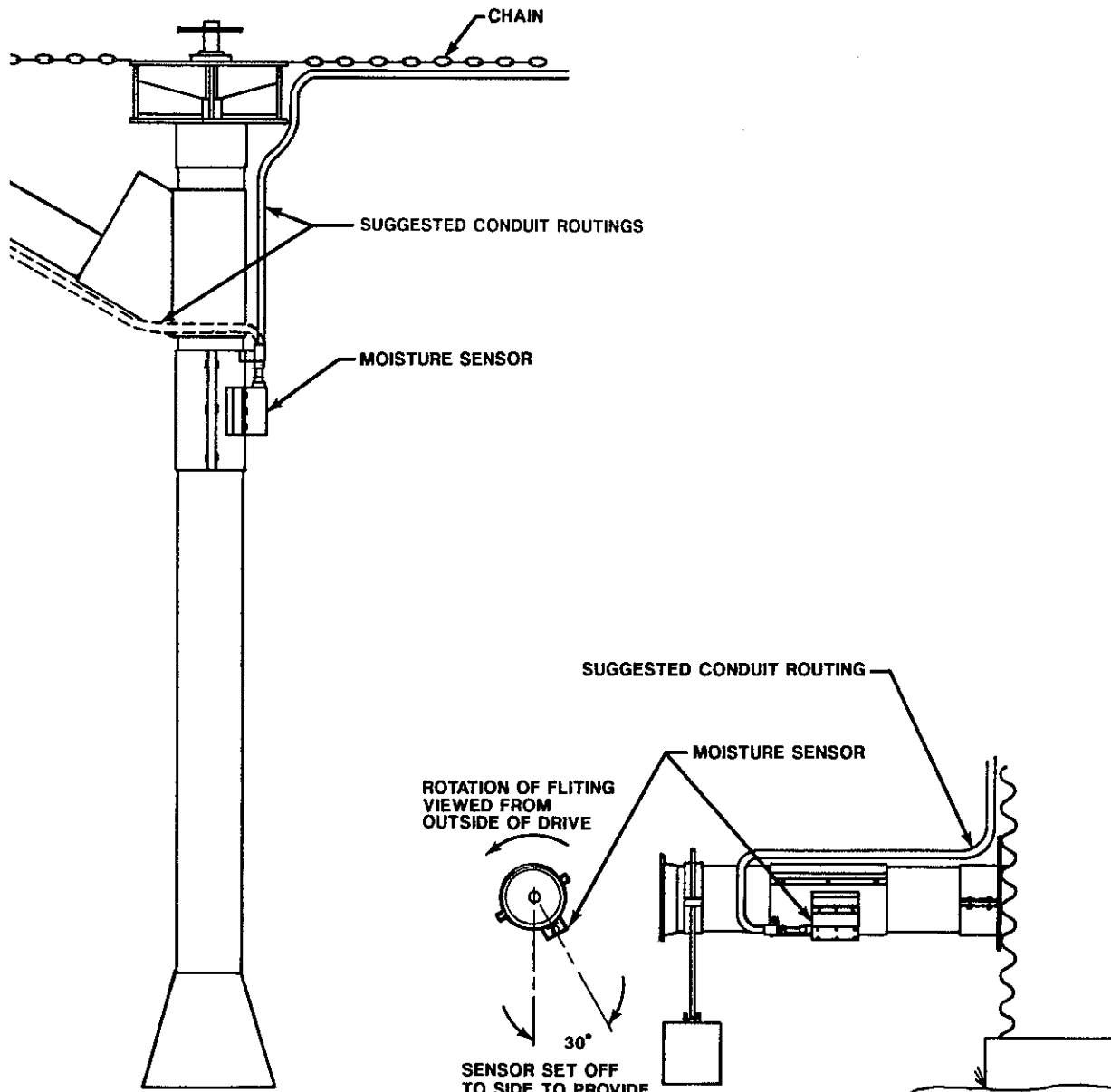

VERTICAL UNLOAD
(CIRCULATOR) MACHINE

HORIZONTAL UNLOAD (DRI-FLO) MACHINE

**MOUNTING THE MOISTURE SENSOR
!!! MAKE SURE ALL POWER IS DISCONNECTED !!!**

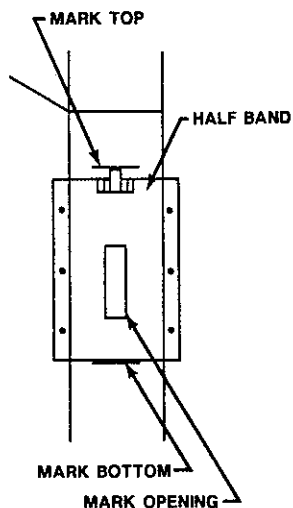

1. Hold the mounting halfband to the discharge auger in the location desired. Mark the outline of the rectangular opening and the end of the halfband location on the tube. Remove the half band.

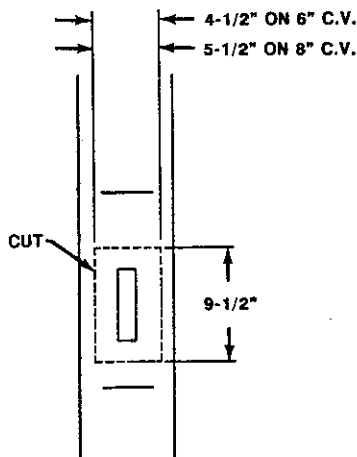

2. Cut a rectangular hole in the discharge auger tube about 2" larger than the outline marked on the tube.

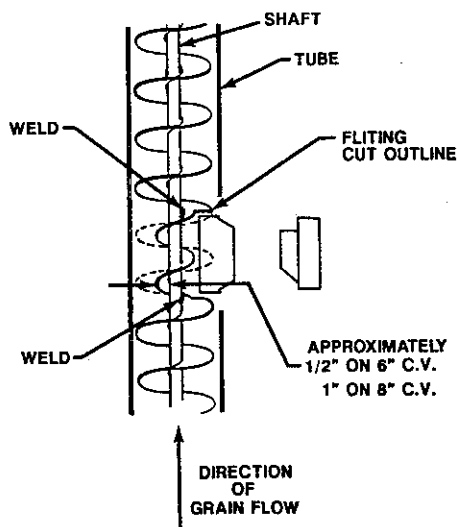

3. Through this opening cut the fliting to clear the Sensor Clearance Gage. NOTE: Weld fliting to shaft solid enough to prevent unraveling before cutting. On a six inch discharge auger there should be approximately 1/2" of fliting left on the shaft. Approximately 1" of fliting should remain on an 8" auger.

4. Mount the half bands on the center vertical. Insert the Sensor Clearance Gage and have someone rotate the center vertical auger by hand to insure clearance.

4. Attach the Moisture Sensor with (4) 1/4-20x1/2 hex head cap screws and lock washers.

PLENUM TEMPERATURE PROBE INSTALLATION

The Plenum Temperature probe is used to sense the temperature of the plenum. The probe is supplied with fifteen (15) feet of cable attached. Extension kits are available if needed. It should enter the Comp-U-Dry control box through the hole provided in the lower left corner.

Drill a 5/32 inch diameter hole in the plenum about 1/2 way between the bin floor and the drying floor. The hole should be on a ridge of the bin sheet. Insert a wire to make sure the hole is not obstructed by a floor leg or other structure. If clear, redrill the hole with a 1/2 inch diameter drill. Hold the plenum temperature probe bracket with the right angle conduit mounting flange to the top. Mark the two mounting holes. Remove the bracket and drill the two holes with a 5/32 inch diameter drill. Install the bracket with two #10 sheet metal screws provided.

Insert the temperature probe until the black plastic coating is resting on the metal bracket for proper temperature readings. See page 11.

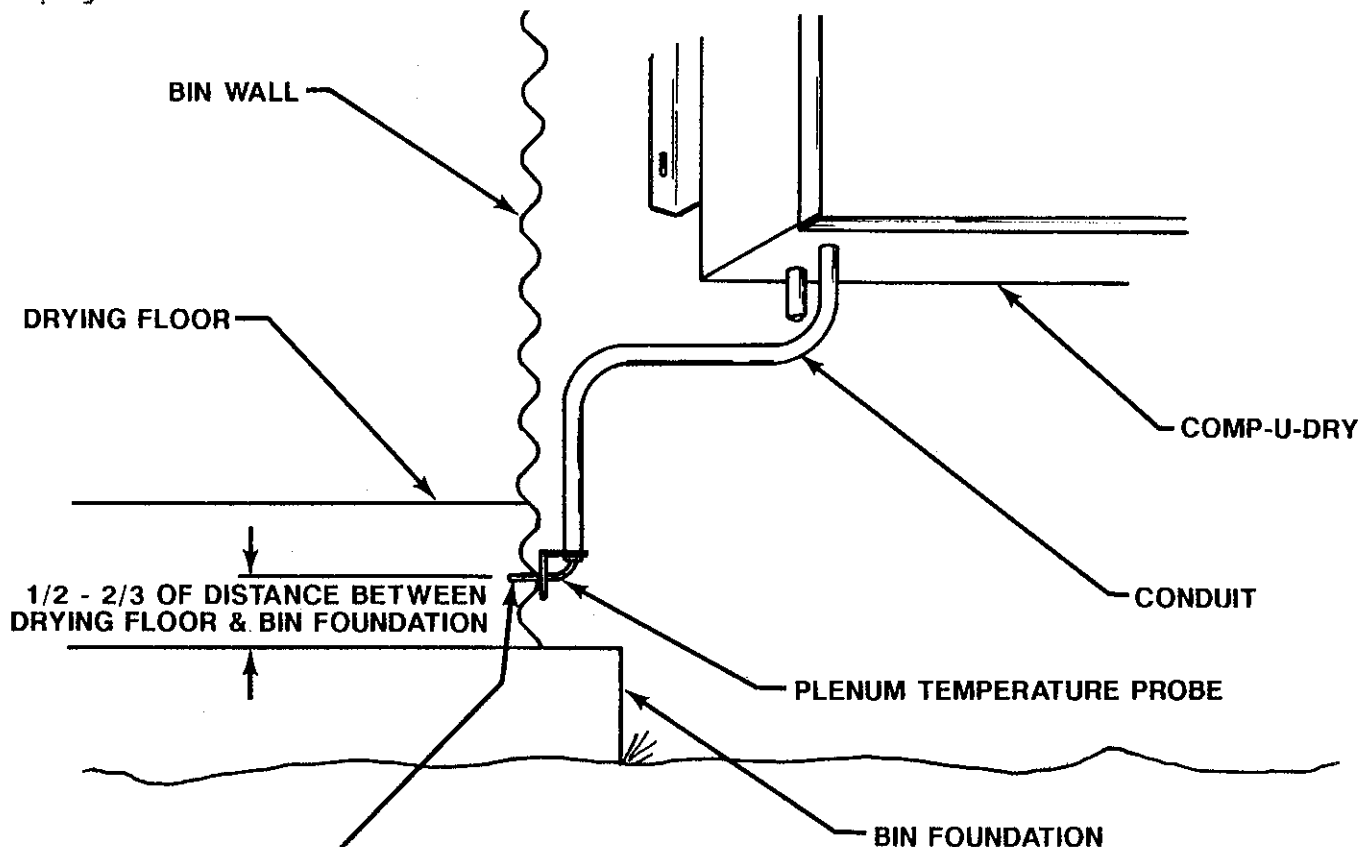

NOTE: The air must exhaust freely from the plenum around the probe to insure that the plenum air temperature is being sensed.

Due to variations of temperature around the bin, it may be desirable to locate the plenum temperature sensing probe near the existing plenum probe for better temperature correlation.

COMP-U-DRY ELECTRICAL INSTALLATION

There are four systems which need to be connected to the Comp-U-Dry Grain Dryer Control. They are as follows:

- 1) **MOISTURE SENSOR....**Requires a 4 pair shielded cable. Seventy five (75) feet provided with the unit. Extension kits are available. It should be installed in conduit or otherwise protected from the elements. **DO NOT RUN OTHER HIGH VOLTAGE (110 volt) WIRES IN THE CONDUIT.**

- 2) **THE PLENUM TEMPERATURE PROBE..**Fifteen (15) feet of temperature sensor wire is supplied with the Comp-U-Dry. It should be installed in conduit or otherwise protected from the elements. **DO NOT RUN OTHER HIGH VOLTAGE (110 volt) WIRES IN THE CONDUIT.** Temperature Sensor wire and Moisture Sensor cable may be in the same conduit.

- 3) **THE DRYER FAN INTERRUPT.....**Requires three (two interrupt and one neutral) wires supplied by customer. These may be 16 gauge stranded wires and should be in conduit or otherwise protected from the elements. **NOTE: In some burner control boxes the neutral is grounded.**

- 4) **CIRCU-TROL.....**Normally requires nine or ten (eight or nine control and one ground) wires supplied by customer. These should be 16 gauge stranded and should be in conduit or otherwise protected from the elements.

NOTE 1 Use of the conduit for "ground" is not advisable. A ground wire should be run inside each high voltage (110 volt) conduit.

NOTE 2 Comp-U-Dry operates on 110 volts AC which is supplied from the Circu-Trol. For operation on other voltages, contact the factory.

NOTE 3 When installation is complete, the various control functions may be checked using the Comp-U-Dry Utility program. See the Comp-U-Dry G2 operating instructions.

**WIRING THE 10 POINT "I" TERMINAL STRIP
MOISTURE SENSOR AND PLENUM TEMPERATURE PROBE**

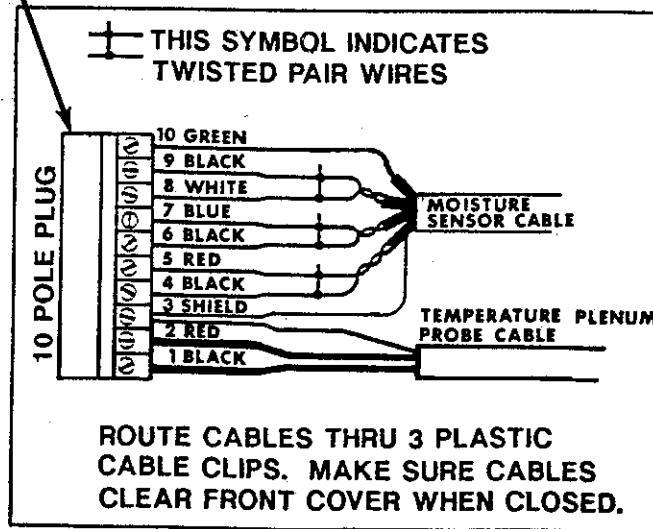
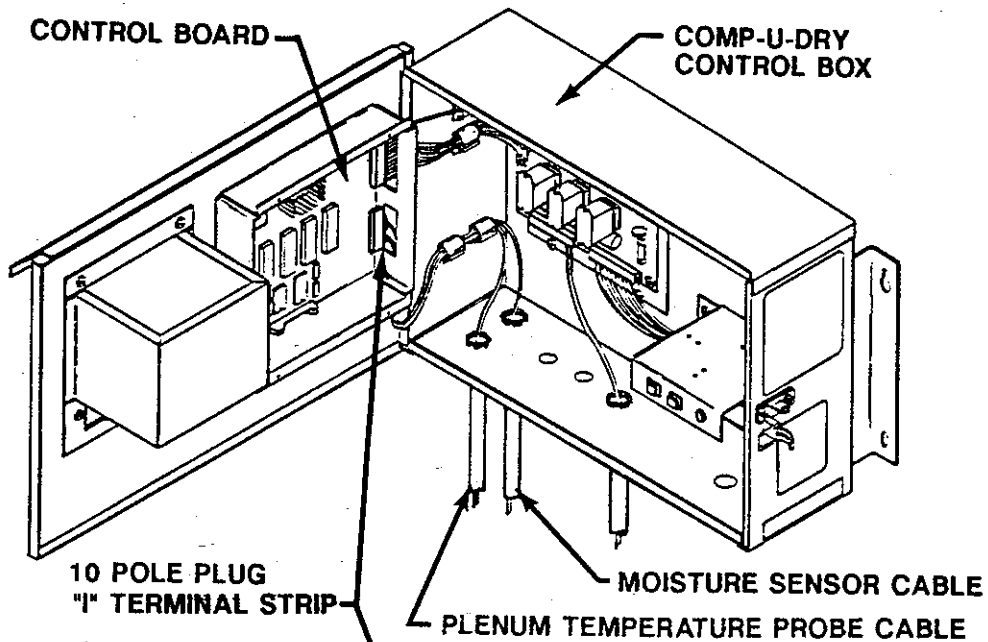

1. Terminals 1 and 2 are for Plenum Temperature Probe.
2. Terminal 3 is neutral for both Plenum Temperature Probe and Moisture Sensor.
3. Terminals 4 through 10 are for Moisture Sensor.

NOTE: Wires in Moisture Sensor Cable are in twisted pairs within the cable shielding. When untwisting for installation, they should be marked with tape to maintain the pair identity.

WIRING THE MOISTURE SENSOR

Seventy five feet of 4 pair shielded cable is provided with the Comp-U-Dry with a polarized plug attached to one end.

1. Make sure cord grip is screwed into mounting halfband. Draw the cable thru the cord grip and the conduit into the lower left corner of the Comp-U-Dry Control Box.
2. Attach the polarized plug to the Moisture Sensor after it is installed on the auger tube. Tighten the cord grip.
3. Cut cable for routing through two cable clips in the control box and one cable clip on the door and wiring to 10 pole plug. Carefully strip off outer insulation and identify wire pairs using black tape or shrink tubing. When completed, the cable ends should look similar to the cable as received from the factory. It is good practice to tin the ends of the wires with solder.
4. Install the wires per the diagram below.

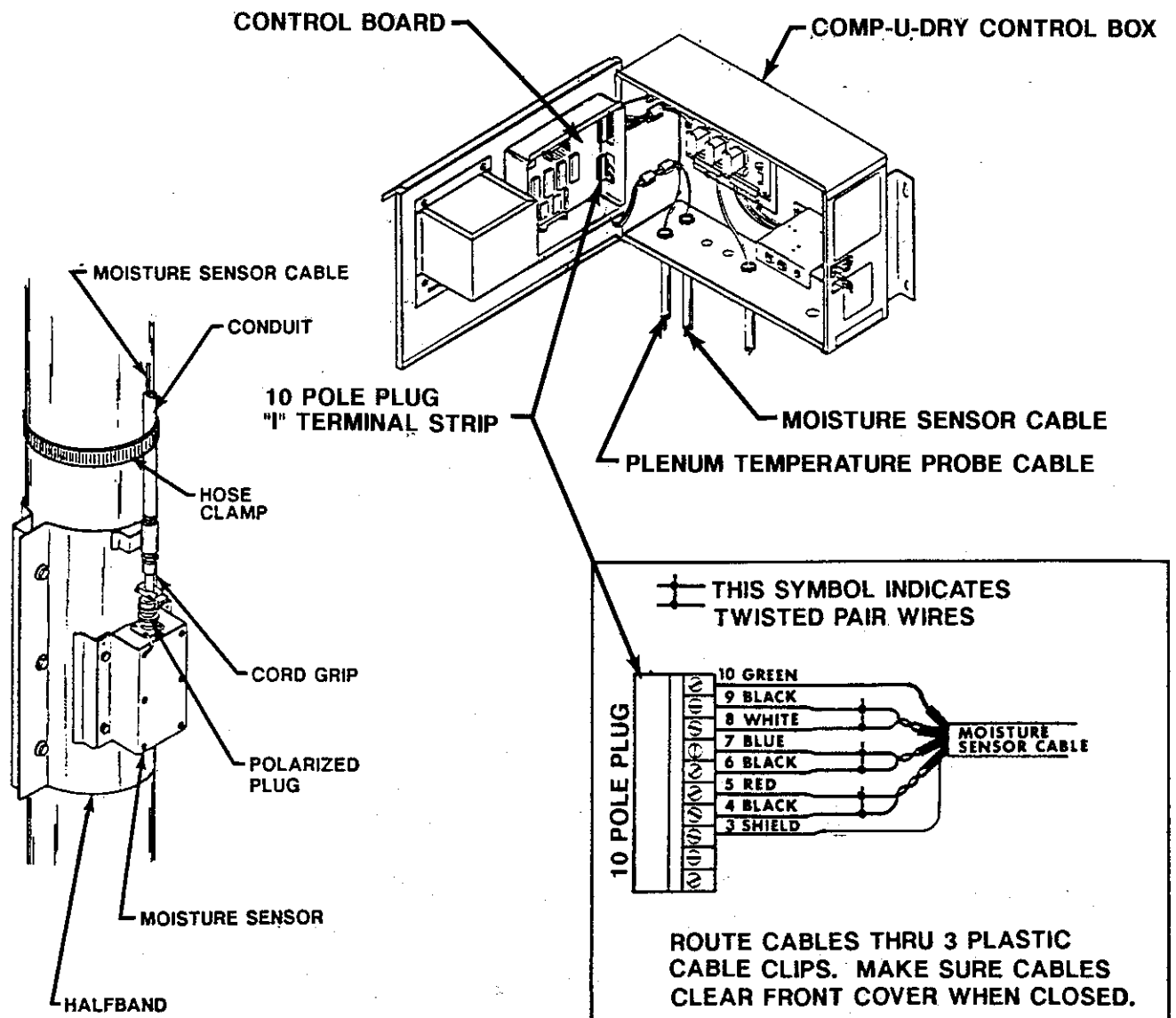

WIRING THE PLENUM TEMPERATURE PROBE

The plenum temperature probe has 15 feet of cable attached to it.

1. Insert the Plenum Temperature Probe into the drying bin thru the Plenum Temperature Probe Mounting Bracket until the black plastic coating is resting on the mounting bracket. Draw the cable thru the conduit into the lower left corner of the Control Box.
2. Thread the cable thru the two cable clips on the bottom left side of the control box and up thru the cable clip attached to the door.
3. Cut and carefully strip the cable for insertion into the 10 pole plug. When complete, the cable end should look similar to the cable as received from the factory. It is good practice to tin the ends of the wires with solder.
4. Install the wires per the diagram below.

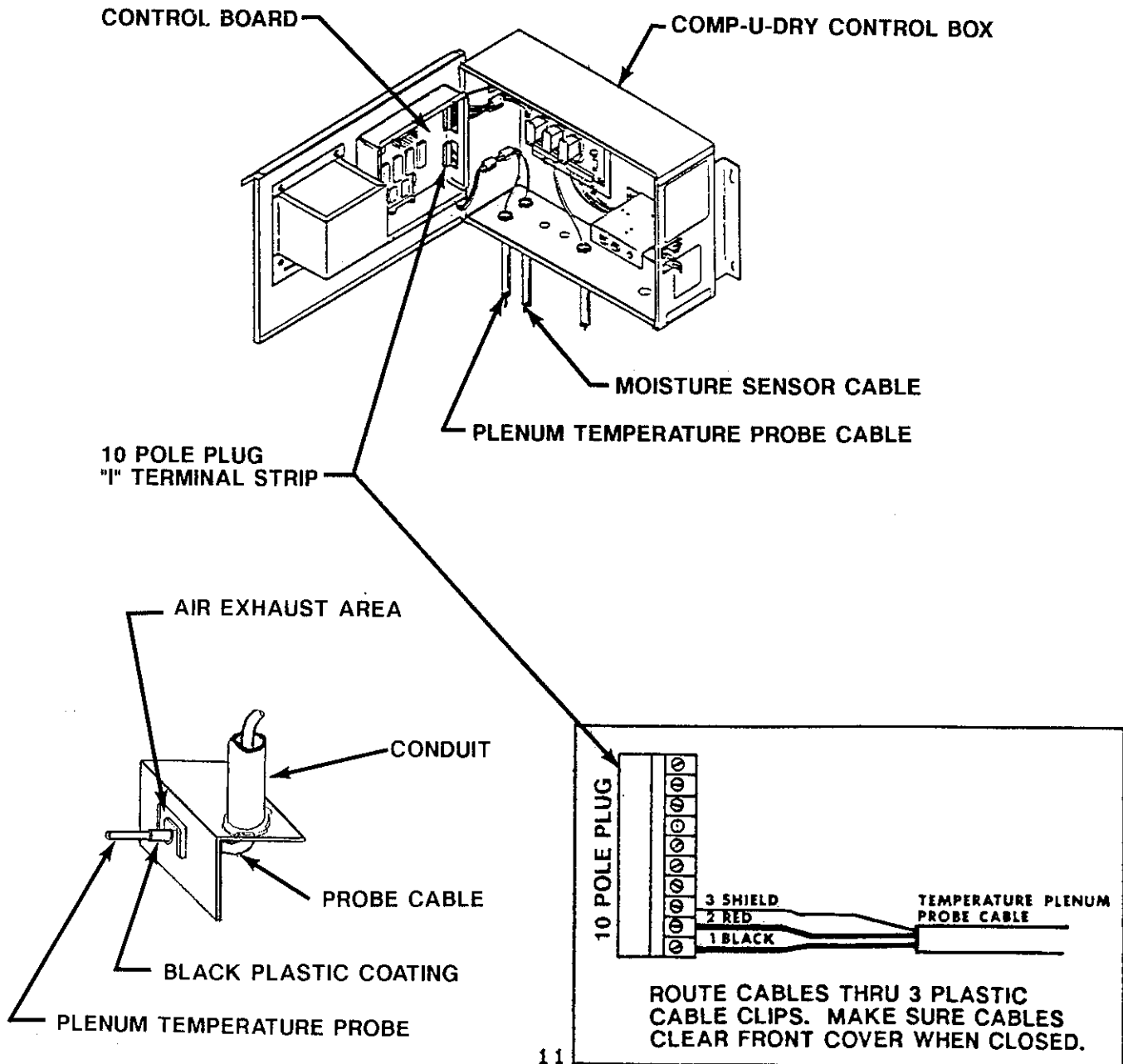

FUNCTIONAL DESCRIPTION AND EXPLANATION OF
16 POINT "F" TERMINAL STRIP

Except for the Moisture Sensor and Plenum Temperature Probe cables, all connections from the Comp-U-Dry Control Box to the grain dryer are made to the 16 point "F" terminal strip. Understanding the function of this terminal strip is helpful in wiring and trouble shooting the unit.

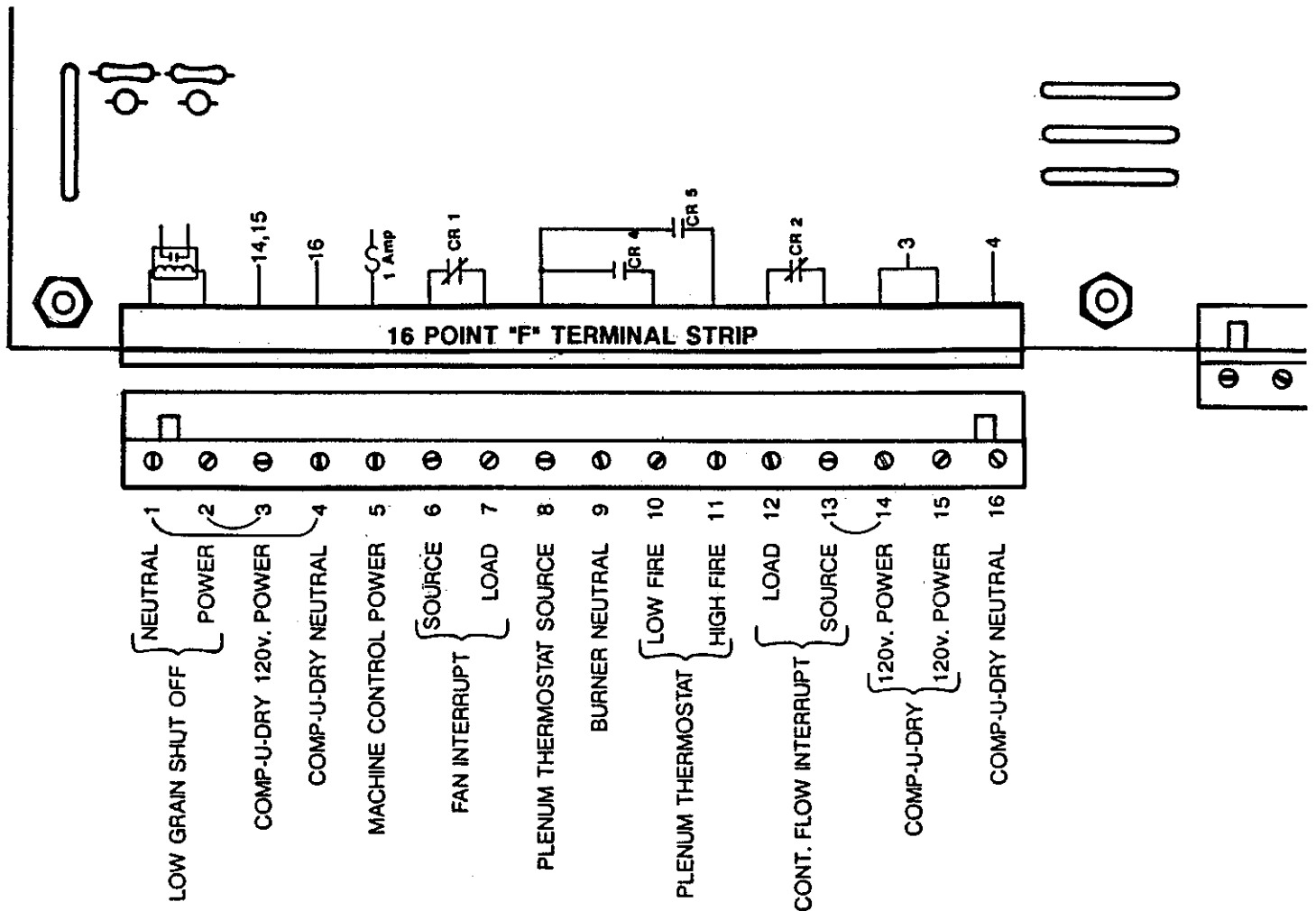

1. Power (110 volts fused for 5 amps) must be supplied to the Comp-U-Dry on terminal 15. Terminals 3, 14, and 15 are connected together on the Relay board. When power is applied to terminal 15, it will also be present on terminals 3 and 14.

2. Terminal 16 is the Comp-U-Dry neutral. It is also connected to terminal 4. When terminal 16 is connected to neutral, terminal 4 will also be neutral.

3. The Comp-U-Dry controls the discharge augers by supplying 110 volt, 1 amp power on terminal 5. The power side of the coil of the discharge auger contactor should be connected to terminal 5. The neutral side of the auger contactor coil should be the same neutral as connected to the Comp-U-Dry neutral on terminal 16.

16 POINT "F" TERMINAL STRIP CONTINUED

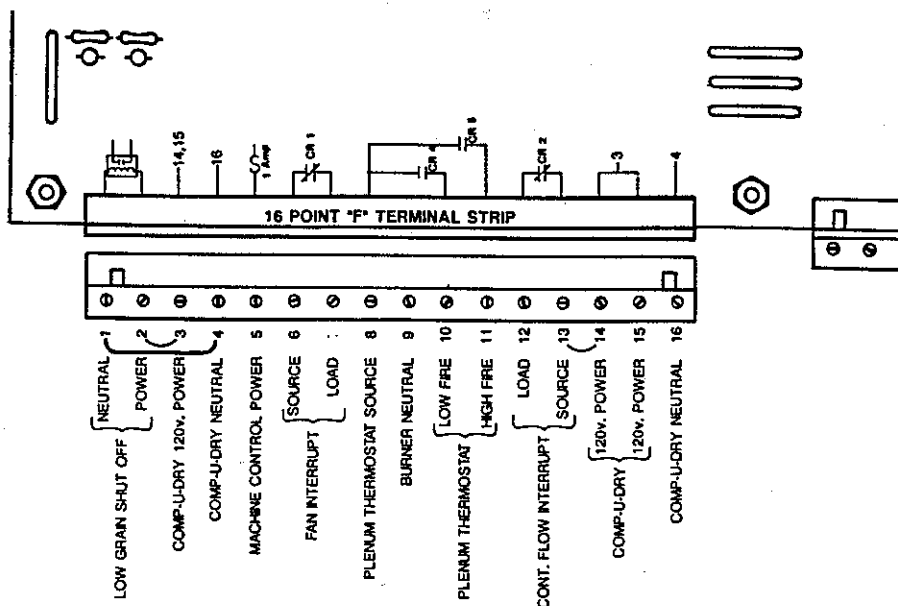

4. To prevent transfer of wet grain during the sample cycle, an interrupt is provided on terminals 13 and 12. The source power for the continuous flow or transfer auger contactor coil should be wired to terminal 13. Terminal 12 will then be wired as the load, (to the auger contactor coil). This circuit will be normally closed except when interrupted by the Comp-U-Dry during the sample cycle. The Comp-U-Dry is shipped with a jumper between terminals 13 and 14.

5. The Comp-U-Dry will control the grain dryer burner through terminals 8,9,10,and 11. The source power for the plenum thermostat should be wired to terminal 8. When low fire is indicated this power will be available on terminal 10, which should be wired to the low fire or on-off burner solenoid. For two stage burners power will be available on terminal 11 for high fire. The burner control neutral should be wired to terminal 9. NOTE: Some non-Shivvers burners have separate (4-wire) Hi-Lo thermostat circuits. They will require a relay to function properly. See page 42 for wiring instructions.

6. To allow the Comp-U-Dry to shut the fan down one hour after the bin is out of grain, an interrupt is provided between terminals 6 and 7. The power to the fan motor contactor coil should be wired in series to terminal 6 and 7, with the source side on terminal 6. This will not operate unless the "bin out of grain" or "low grain shutoff" is connected.

7. Terminals 1 and 2 are used to inform the Comp-U-Dry when the bin is empty in drying systems that have a "bin out of grain" or "low grain shutoff". Power (110 volts) must be supplied to terminal 2 when the bin is full. Terminal 1 is the neutral for this power. The "bin out of grain" or "low grain shutoff" will open either the power or neutral to inform the Comp-U-Dry when the bin is empty. The Comp-U-Dry is shipped with a jumper from terminal 2 to 3 (power) and a jumper from terminal 1 to 4 (neutral) to allow operation on drying systems with no "low grain shutoff".

CONNECTING THE DRYER FAN INTERRUPT

The purpose of the dryer fan interrupt is to allow the Comp-U-Dry to shut down the fan one hour after the low grain shutoff indicates the bin is out of grain. Three wires should be run from the fan control box to the Comp-U-Dry. They are a white neutral wire and two interrupt wires. In some burner control boxes the neutral is grounded.

The interrupt lines normally provide a continuous circuit while running, but one hour after low grain shut down they are open for 5 seconds to interrupt the fan contactor hold in circuit. The interrupt lines should be installed in series with the fan stop switch.

For Shivers crop dryers, a jumper (wire #31) is installed between terminal N and G of the Fan control terminal strip. This jumper provides continuity for the fan motor contactor coil interlock circuitry, and must be removed when installing the fan interrupt.

CONNECTING SHIVERS UHP FAN

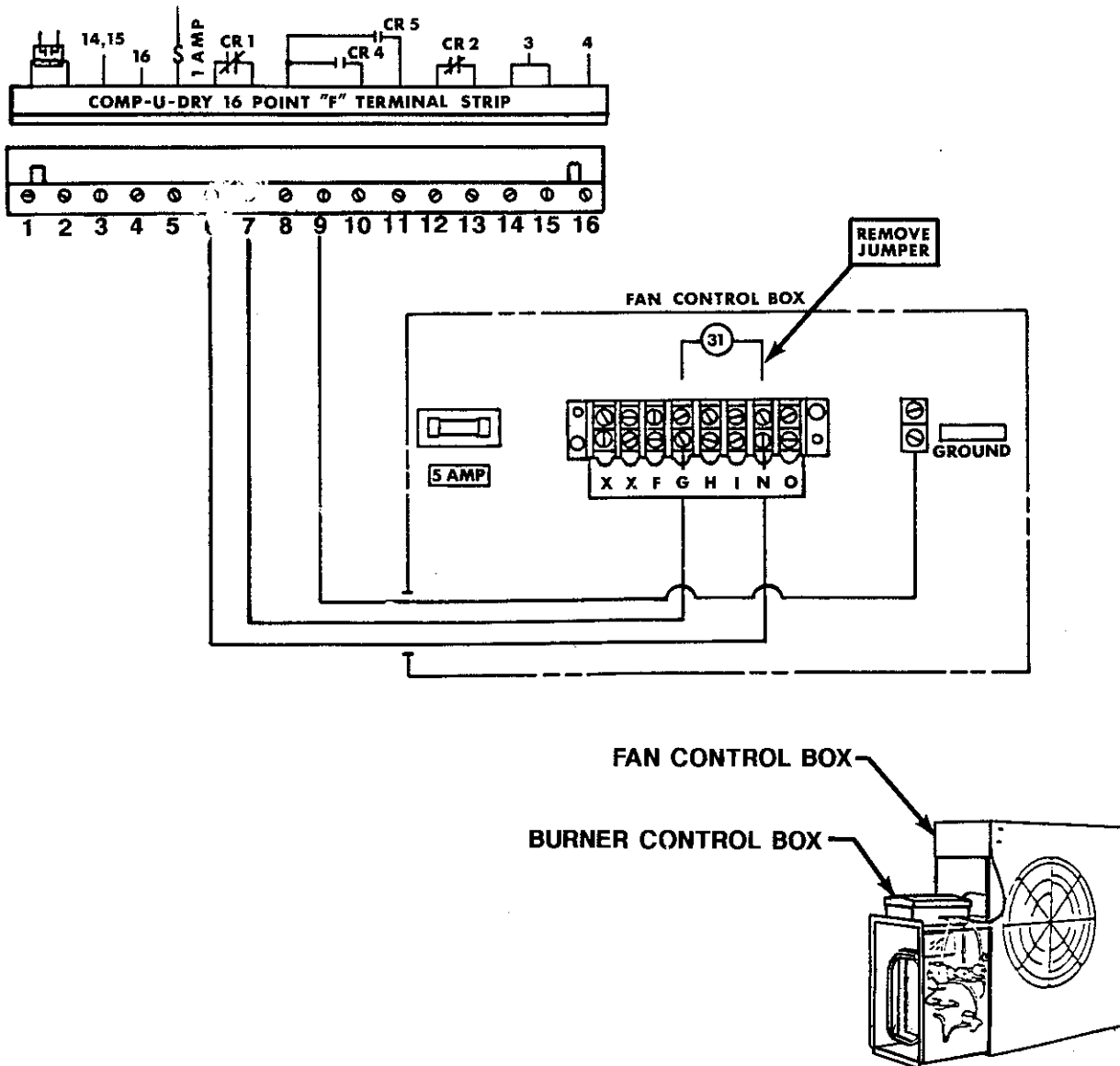

CONNECTING DRYER FAN INTERRUPT FOR SHIVVERS BLUE FLAME AND BIG BLUE BURNERS

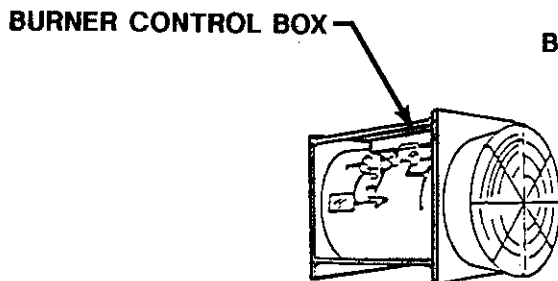
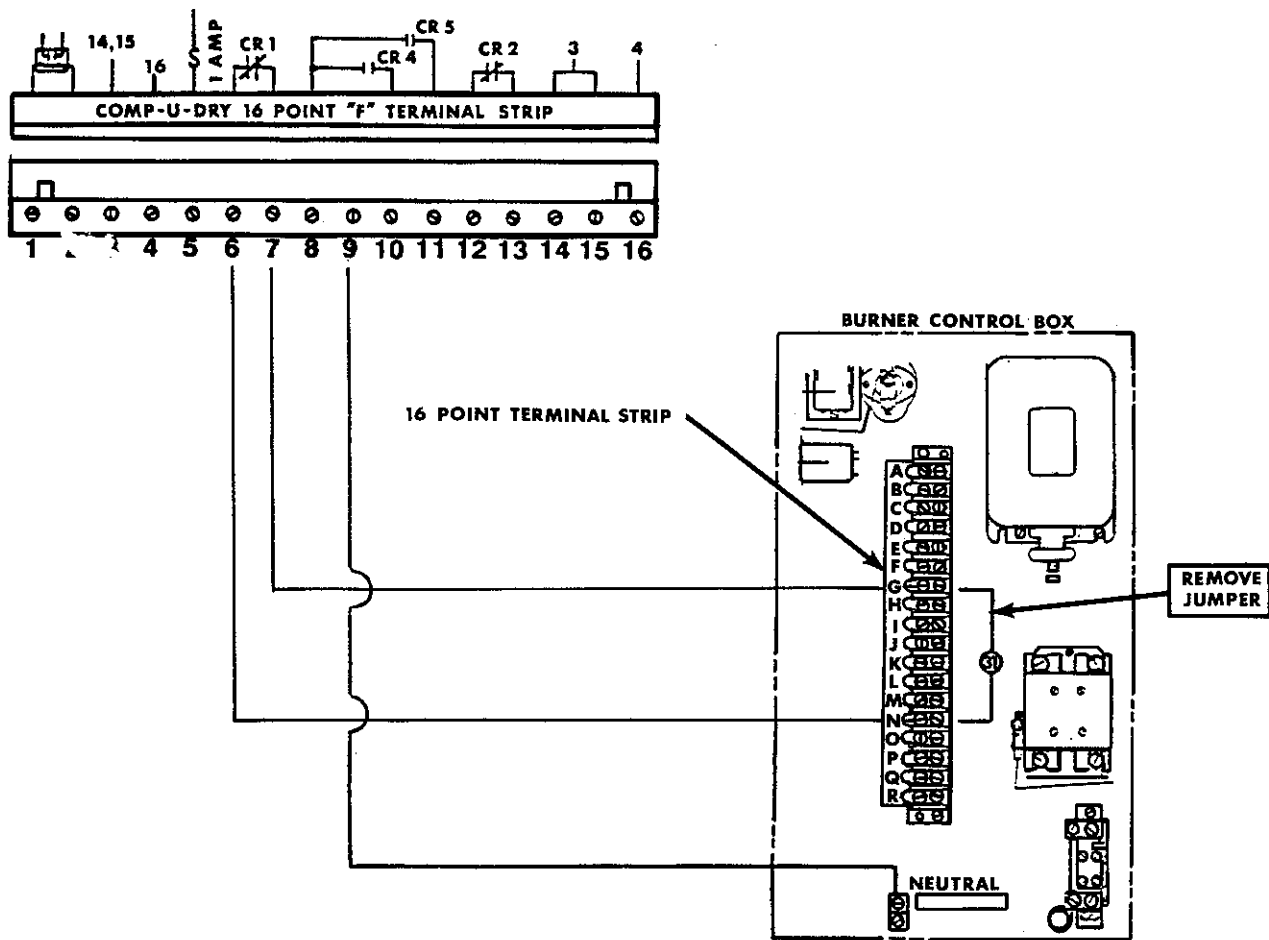

BLUE FLAME BURNER
(SINGLE BURNER INSTALLATION)

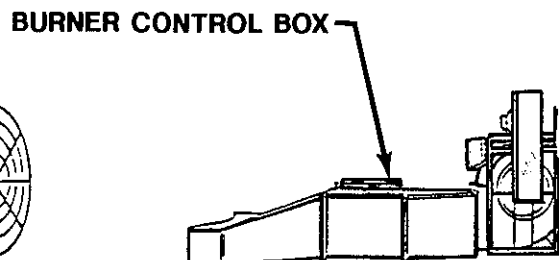

OR
BIG BLUE BURNER
(SINGLE BURNER INSTALLATION)

NOTE: The neutral line MUST BE installed even though the customer does not want the Comp-U-Dry to shut the fan down automatically.

WIRING FAN INTERRUPT WITH GRAIN HI LIMIT CONTROL BOX

For a Shivers two burner installation a GRAIN HI-LIMIT CONTROL BOX is used to control both fans. In this case, the fan interrupt lines from the Comp-u-dry 16 point "F" terminal strip terminals 6 & 7 should wire to terminals 4 & 5 respectively of the GRAIN HI-LIMIT CONTROL BOX. The jumper between terminals 4 & 5 should be removed.

A jumper should be installed between terminal 9 and terminal 4 of the Comp-u-dry 16 point "F" terminal strip instead of wiring burner neutral to terminal 9.

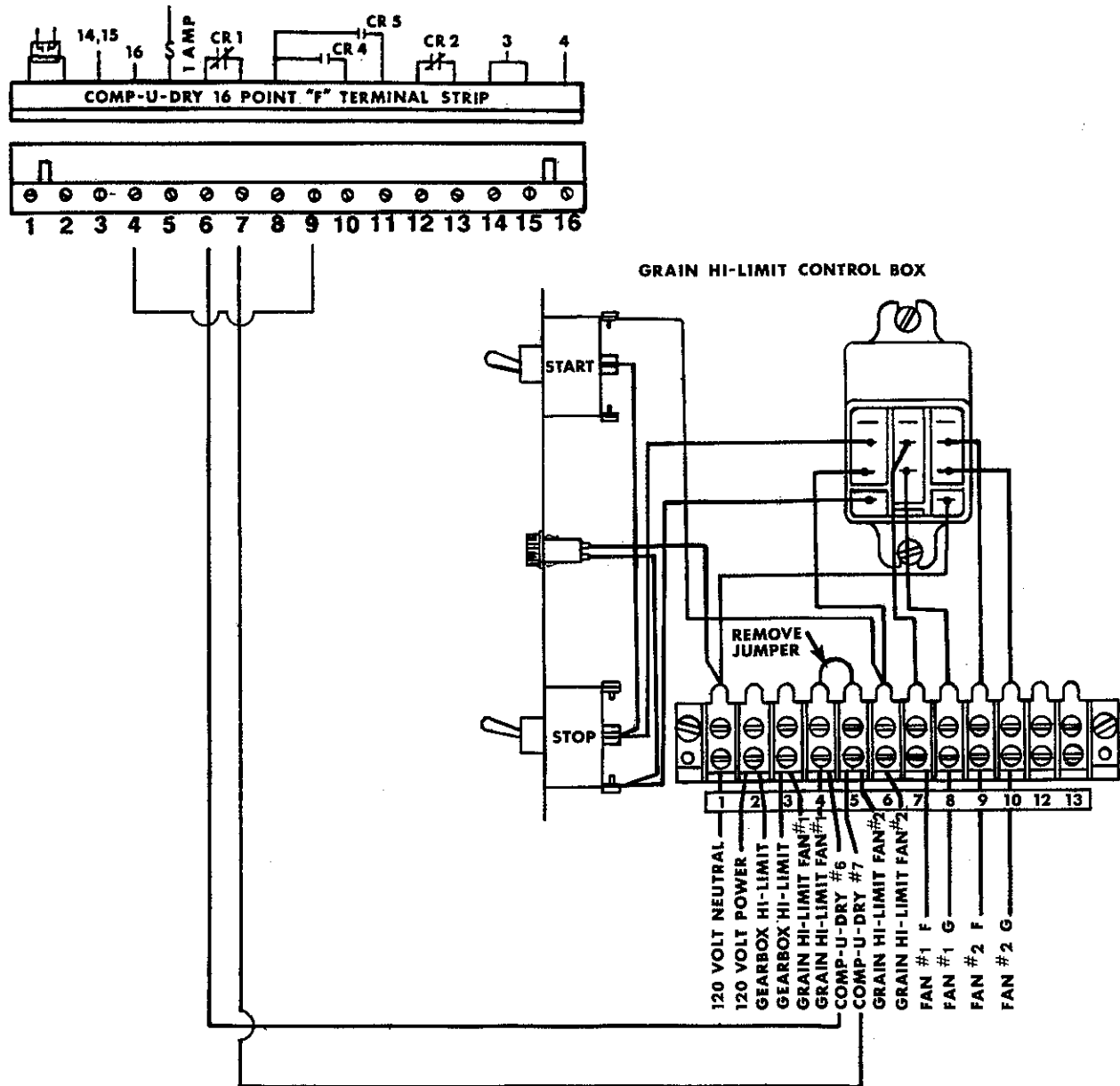

NOTE: Some grain hi-limit boxes may have the gearbox hi-limit connected between terminals 4 & 5. In this case, remove jumper between terminals 2 & 3 of the grain hi-limit box and connect the fan interrupt to these terminals.

WIRING TO THE DELUXE CIRCU-TROL MODEL 295 OR MODEL 74C

To allow parallel operation of the Comp-U-Dry and the Circu-Trol, a relay must be installed in the Circu-Trol. Also a continuous flow interrupt line must be added to prevent wet grain transfer while the moisture sample is being taken by the Comp-U-Dry.

1. DELUXE (295) CIRCU-TROL RELAY WIRING:

1. Mount the 2 pole relay in any convenient location in the Circu-Trol control box.
2. Remove wire #16 from the grain thermostat "W" terminal and connect it to the "N.O." relay terminal.
3. Remove wire #15 from the grain thermostat "B" terminal and connect it to the "N.C." relay terminal.
4. Connect a wire from the grain thermostat power source "R" terminal to the "common" relay terminal.
5. Connect a wire from the grain thermostat output terminal "W" to the relay "coil" terminal.
6. Connect a neutral wire from the other terminal of the relay coil to neutral terminal "B" in the Circu-Trol.
7. Connect a machine discharge auger control wire from terminal 5 of the Comp-U-Dry 16 point "F" terminal strip to the grain thermostat terminal "W".

11. CONTINUOUS FLOW SWITCH REWIRING:

1. Remove wire #10 from between the Circu-Trol "Machine Switch" and the first "Continuous Flow Switch". Discard this wire.
2. Remove wire #11 from the Circu-Trol "Machine Switch" and reconnect this end to the first "Continuous Flow Switch" where wire #10 had been connected.
3. Connect a continuous flow interrupt wire from the Circu-Trol "D" terminal to terminal 12 of the Comp-U-Dry 16 point "F" terminal strip.

SEE DIAGRAM OF BEFORE AND AFTER WIRING

MODEL 295 OR MODEL 74C DELUXE CIRCUITROL

BEFORE

BOLD WIRES NEED TO BE CHANGED

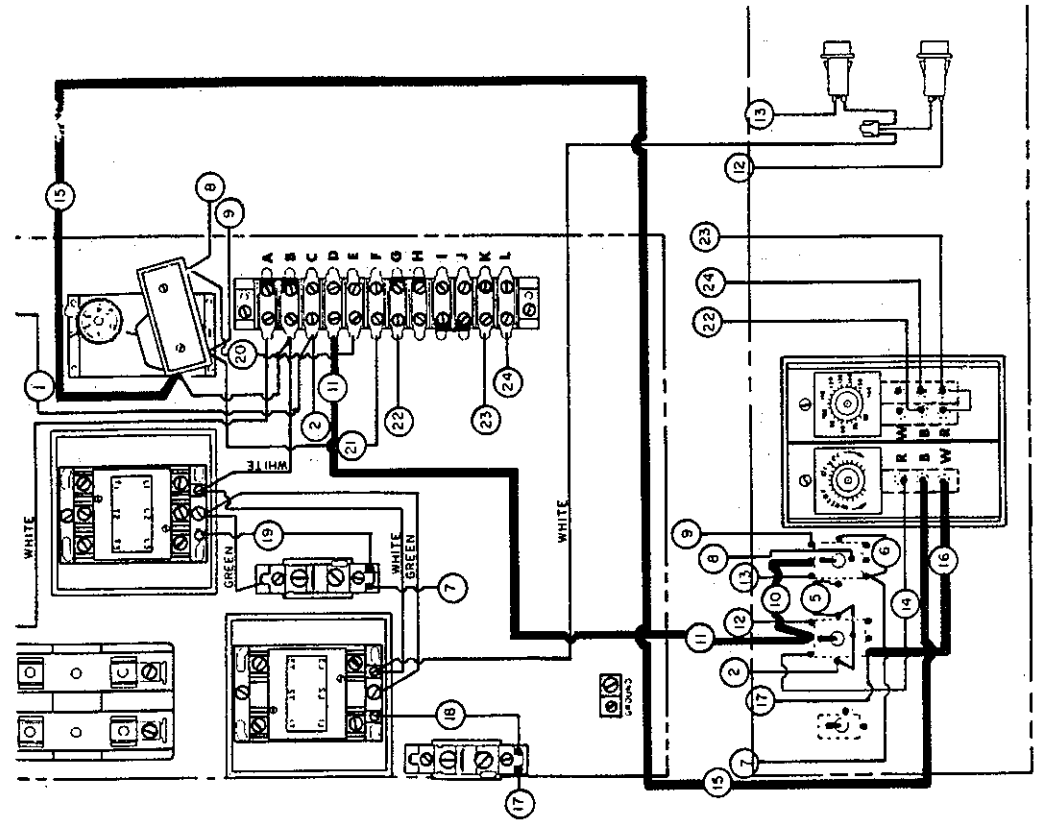

AFTER

BOLD WIRES ARE FINAL CONFIGURATION

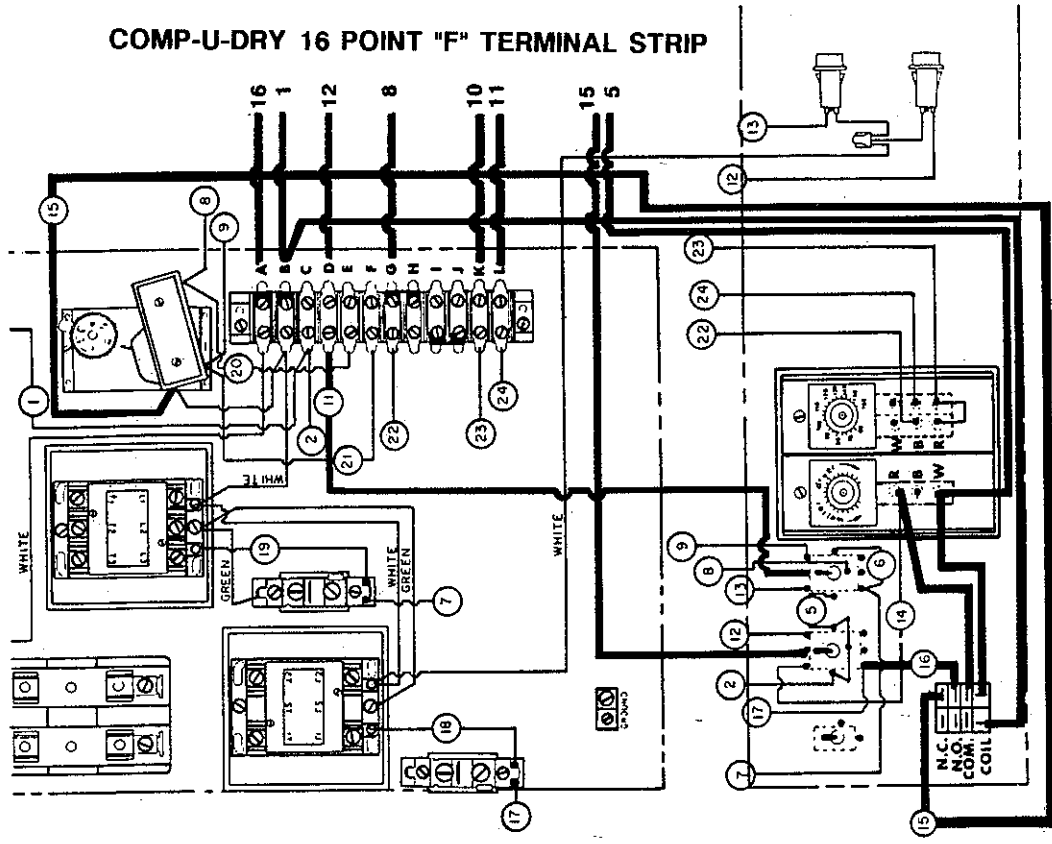

**INTERCONNECTING COMP-U-DRY 16 POINT "F" TERMINAL STRIP
TO DELUXE (MODEL 295 OR MODEL 74C) CIRCU-TROL**

If the Circu-Trol does not have a Low Grain Shutoff (LGSO) connected to it then there should be a jumper installed between terminals 1 and 4 of the Comp-U-Dry 16 point "F" terminal strip. If a Low Grain Shutoff is installed then the jumper (if present) between terminal 1 and 4 of the Comp-U-Dry 16 point "F" terminal strip should be removed and terminal 1 should be connected to terminal "B" of the Circu-Trol.

Some non-Shivvers burners have separate (4-wire) Hi-Lo burner thermostat circuits. They will require a relay to function properly. See page 42 for wiring instructions.

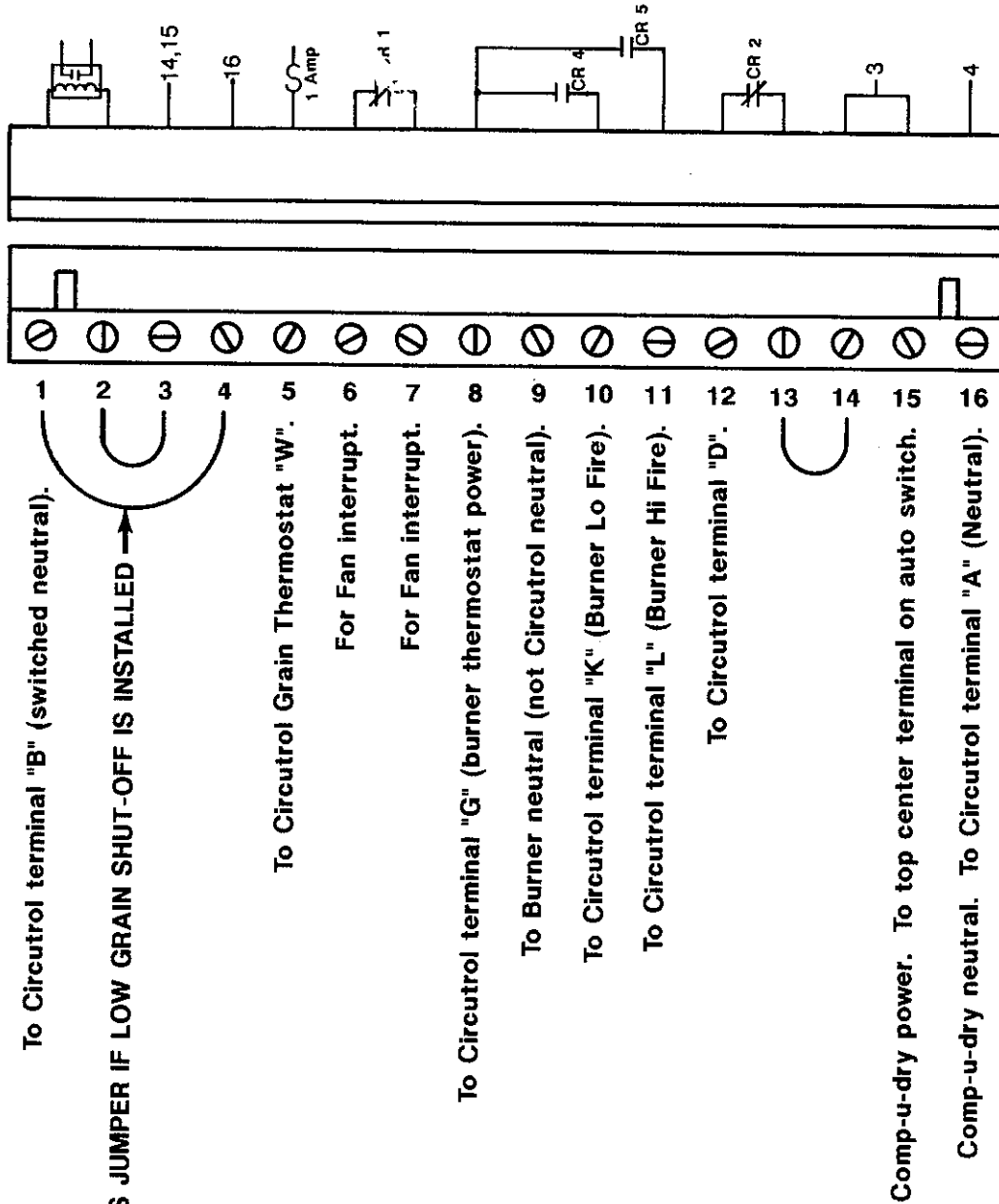

**WIRING TO THE COMPACT CONTROL CENTER
SHOWN WITH AUXILIARY EQUIPMENT KIT
AND LOW GRAIN SHUTOFF**

The basic Compact Control Center provides control for the main discharge auger. If it has an Auxiliary Equipment Kit it will also control a continuous flow auger. The Auxiliary Equipment Kit includes a timer to allow the continuous flow auger to empty after the main auger is turned off. The Compact Control Center also may be wired with a Low Grain Shutoff to turn off the burner when the bin is empty. If a Low Grain Shutoff is installed, an additional two pole relay will be required to permit the Comp-U-Dry to turn off the fan and burner when the bin is empty. This relay will be installed in the Compact Control Center. Wiring is shown below.

For wiring non-Shivvers 4 wire Hi-Lo burner thermostat circuits, see page 42.

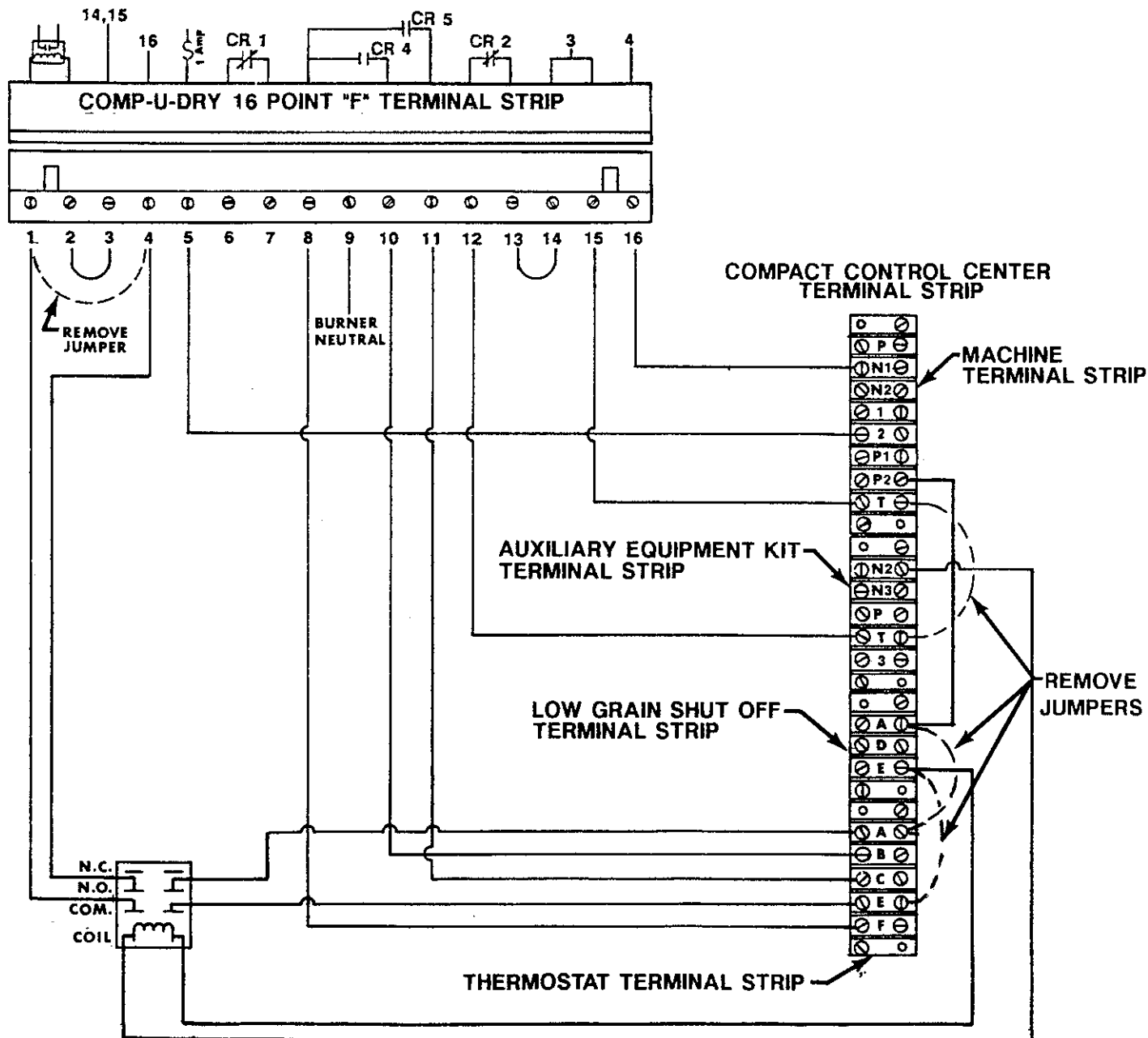

Additional wiring details are on the following pages.

WIRING DIAGRAM OF COMPACT CONTROL CENTER
WITH AUXILIARY EQUIPMENT KIT
BEFORE WIRING TO COMP-U-DRY

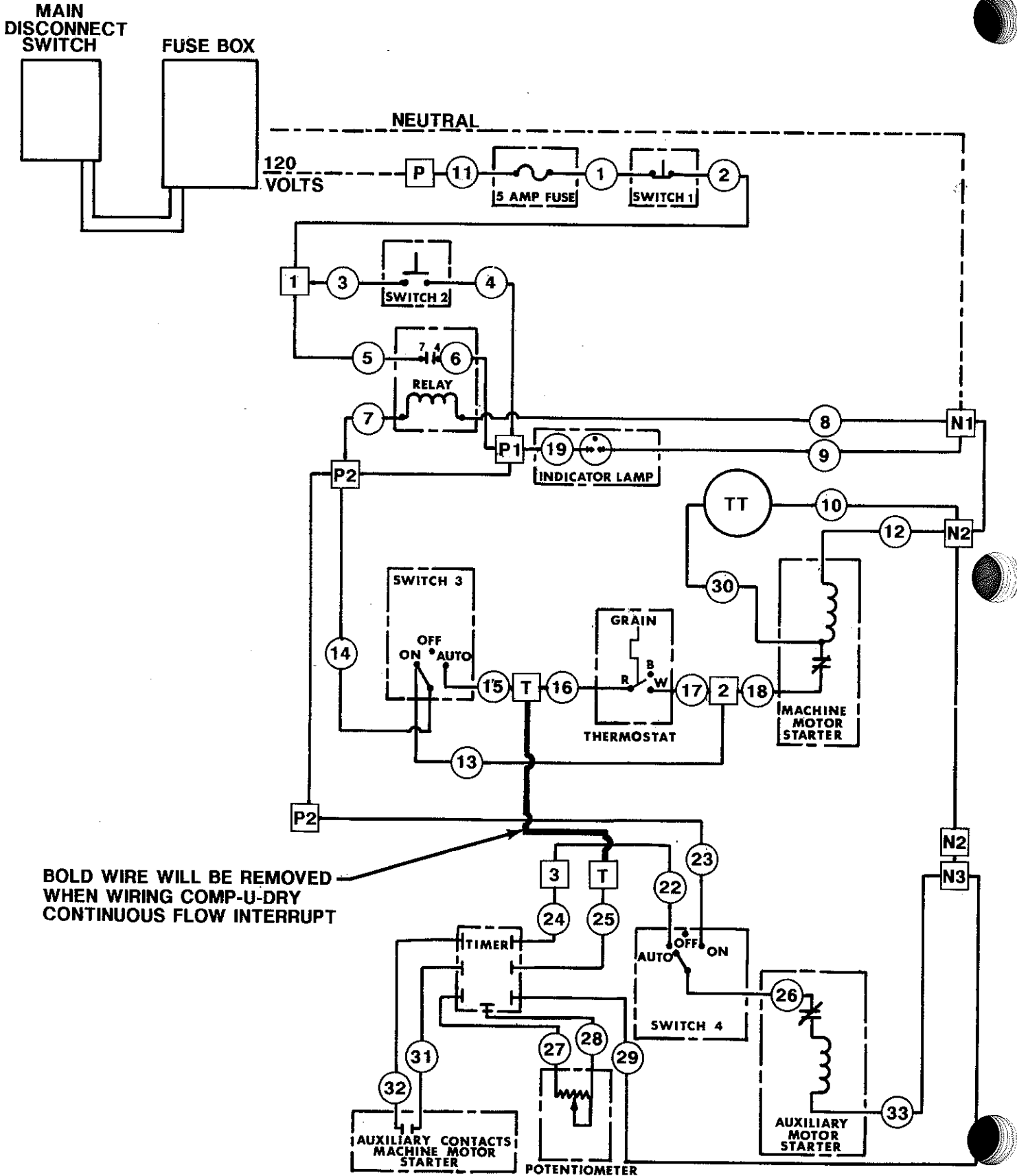

**BOLD WIRE WILL BE REMOVED
WHEN WIRING COMP-U-DRY
CONTINUOUS FLOW INTERRUPT**

WIRING DIAGRAM OF COMPACT CONTROL CENTER
WITH AUXILIARY EQUIPMENT KIT
AND NO LOW GRAIN SHUTOFF
AFTER WIRING TO COMP-U-DRY

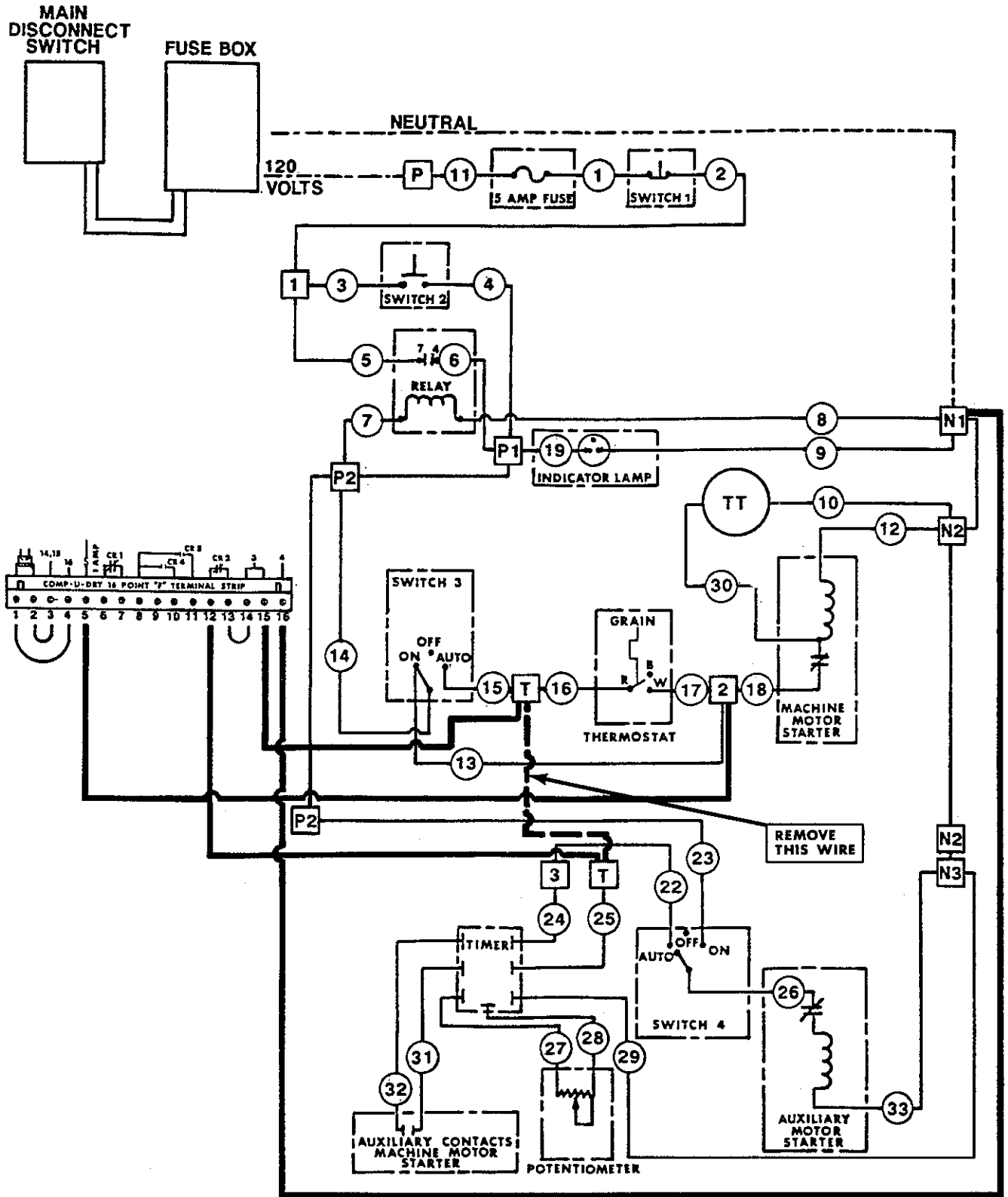

WIRING COMPACT CONTROL CENTER 2 STAGE PLENUM
THERMOSTAT WITHOUT LOW GRAIN SHUTOFF
TO G2 COMP-U-DRY

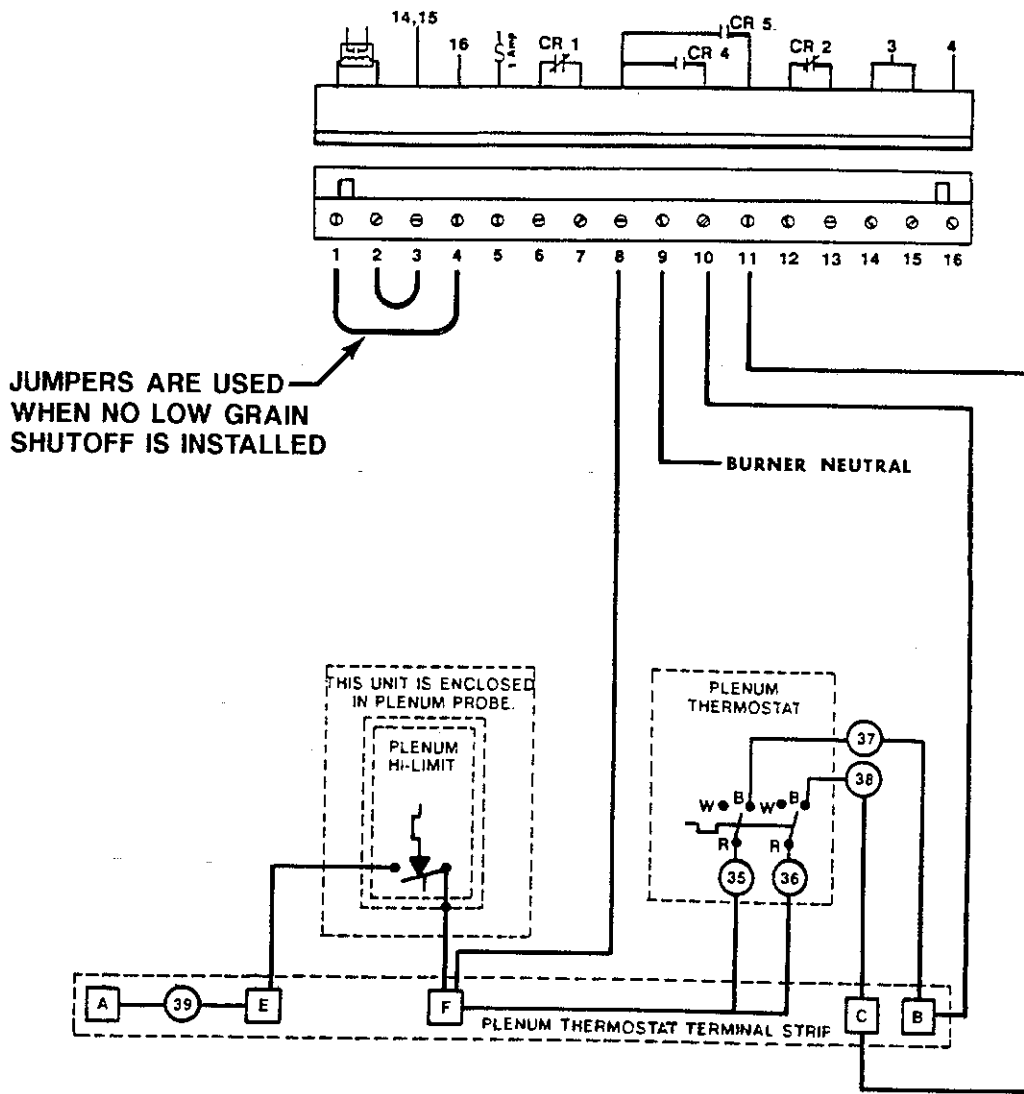

Some non-Shivvers burners have separate (4-wire) Hi-Lo plenum thermostat circuits. They will require a relay to function properly. See page 42 for wiring instructions.

WIRING OF COMPACT CONTROL CENTER 2 STAGE PLENUM
THERMOSTAT WITH LOW GRAIN SHUTOFF
TO G2 COMP-U-DRY

BEFORE

BOLD WIRES NEED TO BE CHANGED

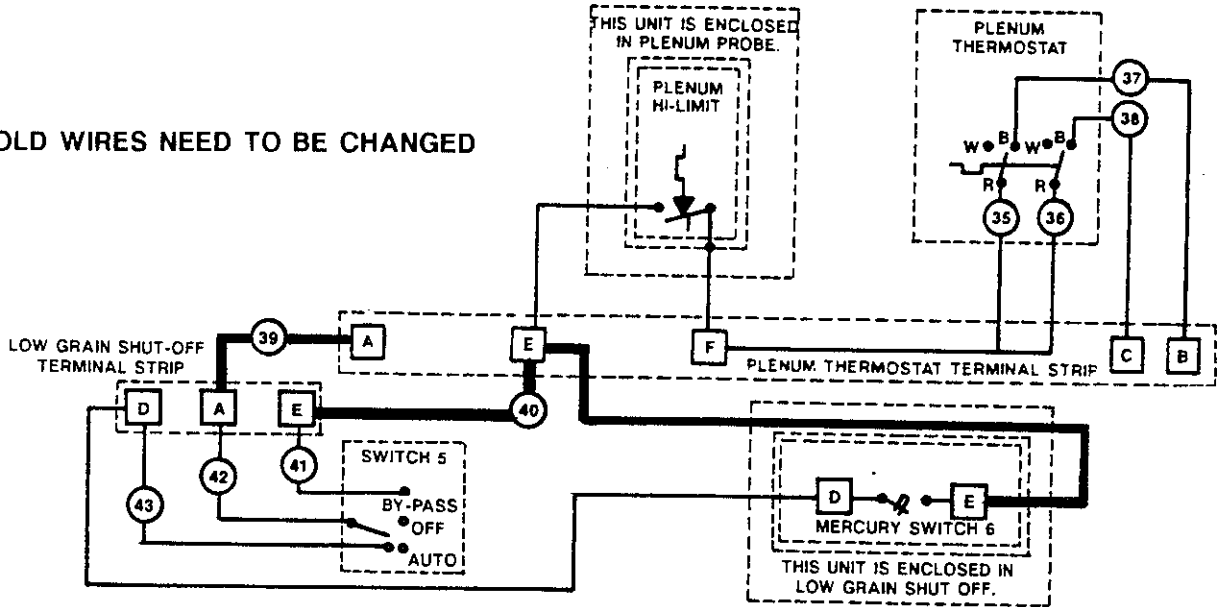

AFTER

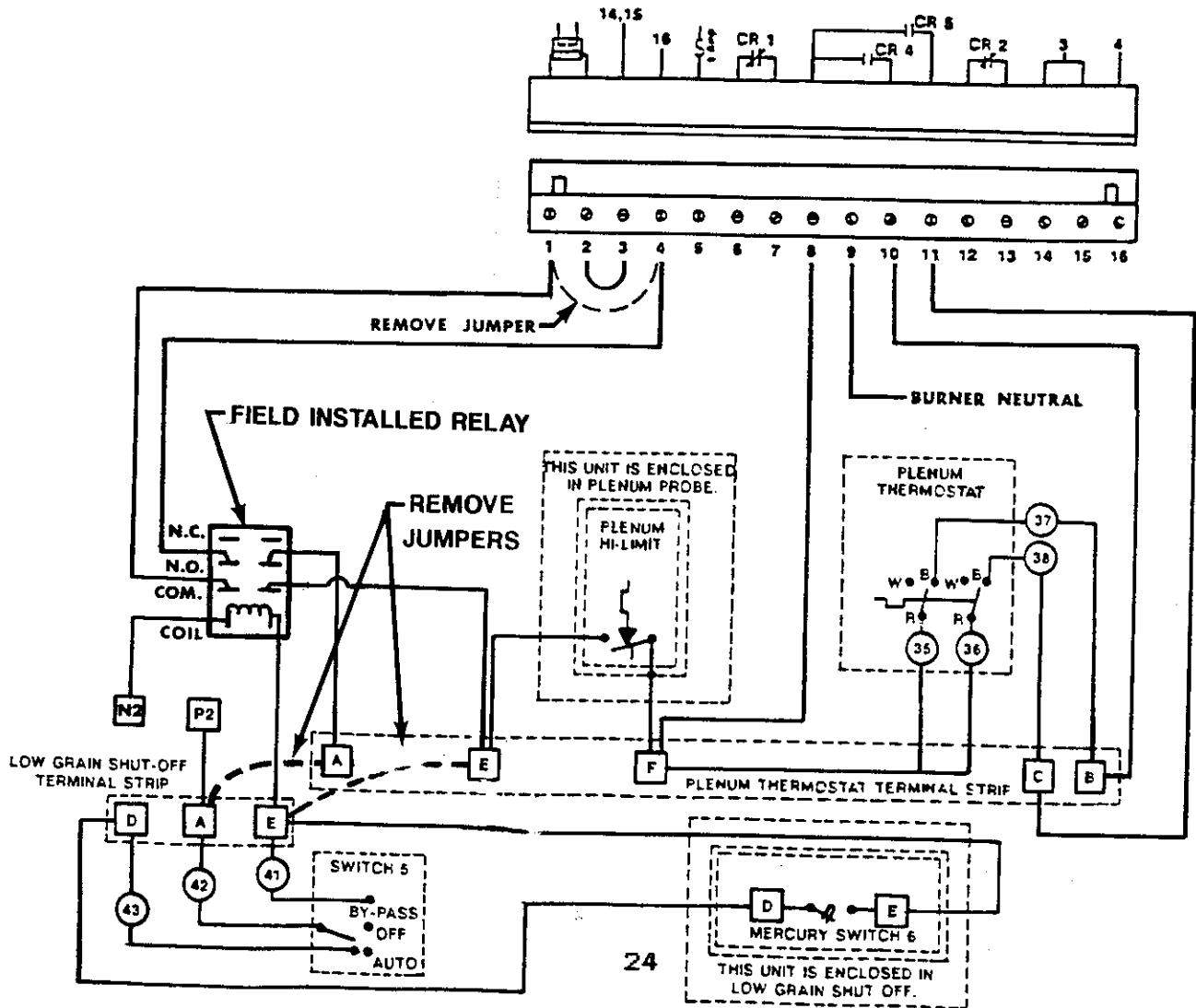

WIRING TO THE SMALL CIRCU-TROL
MODEL SERIES 296

The Comp-U-Dry functions as a parallel system to the Circu-Trol. Either the Circu-Trol or the Comp-U-Dry will control the grain drying operation depending on how the grain and plenum thermostats are set.

To allow parallel operation, a relay must be installed in the Circu-Trol and a continuous flow interrupt line must be added to prevent wet grain transfer while the moisture sample is being taken by the Comp-U-Dry.

SMALL (296) CIRCU-TROL RELAY WIRING:

1. Mount the 2 pole relay in any convenient location in the Circu-Trol.
2. Remove wire 11 from grain thermostat terminal "W" and connect it to the "N.O." relay terminal.
3. Remove wire 13 from the grain thermostat terminal "B" and connect it to the "N.C." relay terminal.
4. Connect a wire from the grain thermostat power source terminal "R" to the relay "common" terminal.
5. Connect a wire from the grain thermostat output terminal "W" to the relay "coil" terminal.
6. Connect a neutral wire from the other terminal of the relay coil to neutral terminal "2" in the Circu-Trol.
7. Connect a machine discharge auger control wire from terminal 5 of the Comp-U-Dry 16 point "F" terminal strip to the grain thermostat terminal "W".

CONTINUOUS FLOW SWITCH REWIRING:

1. Remove wire #3 from between the Circuitrol "Machine Switch" and the "Continuous Flow Switch". Discard this wire.
2. Run a wire from the "Continuous Flow Switch" where wire #3 was attached to terminal 12 of the Comp-U-Dry 16 point "F" terminal.
3. Run a wire from the "Machine Switch" where wire #3 was attached to terminal 15 of the Comp-U-Dry 16 point "F" terminal.

COMP-U-DRY NEUTRAL:

1. Connect a neutral wire from terminal 1 of the small Circu-Trol to terminal 16 of the Comp-U-Dry 16 point "F" terminal strip.

SEE DIAGRAM OF BEFORE AND AFTER WIRING

MODEL 296 (SMALL) CIRCUITROL

COMP-U-DRY 16 POINT "F" TERMINAL STRIP

BEFORE

BOLD WIRES NEED TO BE CHANGED

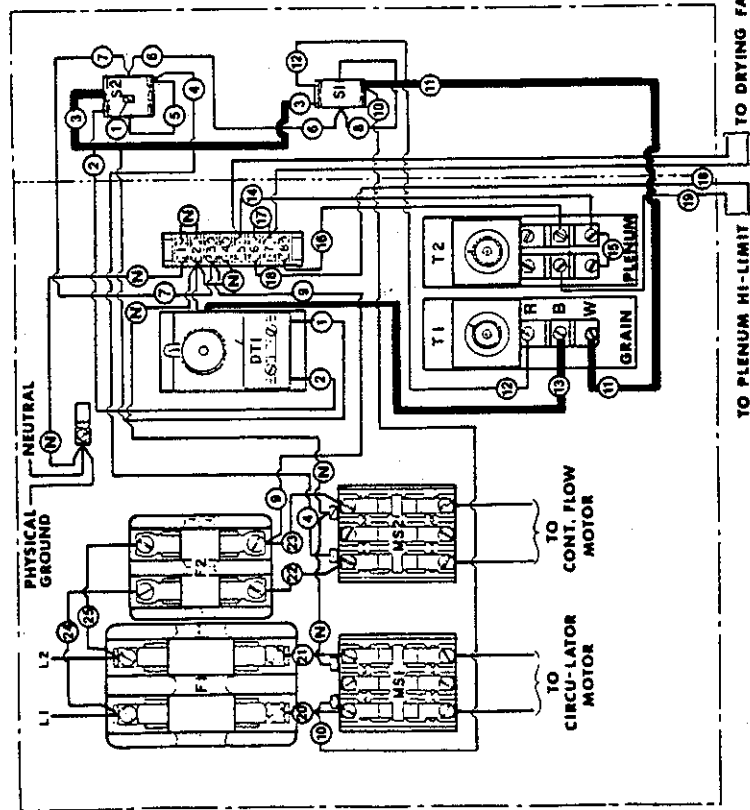

AFTER

BOLD WIRES ARE FINAL CONFIGURATION

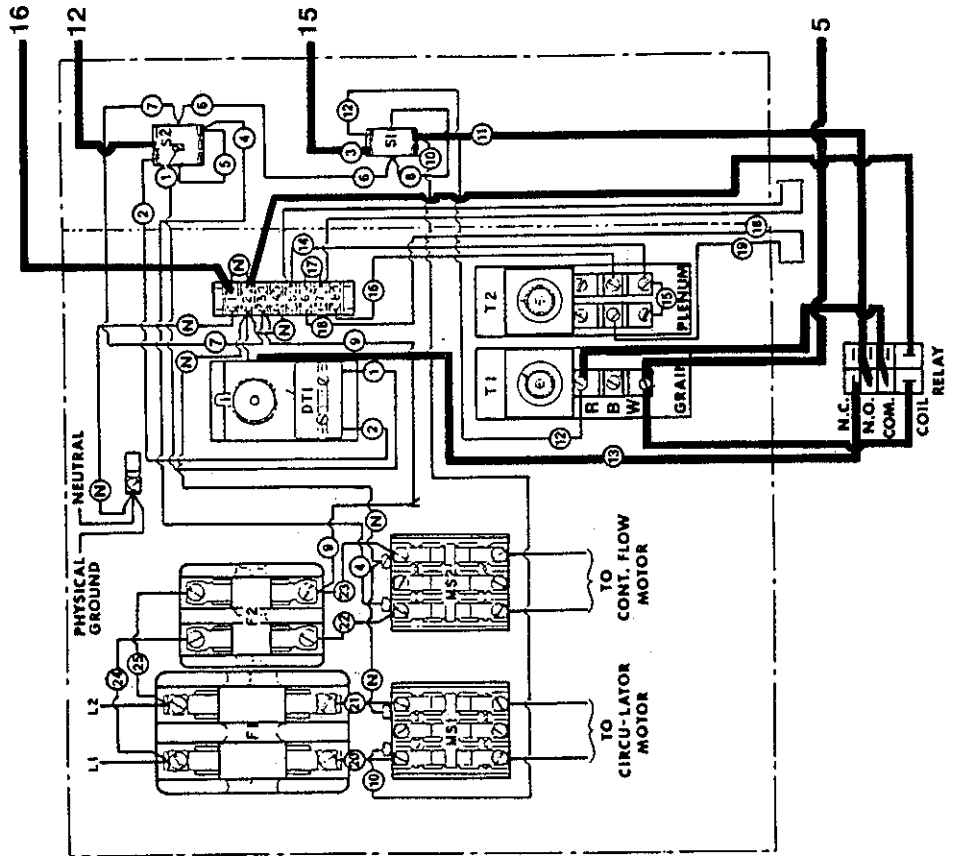

**G-2 COMP-U-DRY
WIRING TO SERIES 296 SMALL CIRCUITROL
2-STAGE PLENUM THERMOSTAT**

**COMP-U-DRY
TERMINAL**

**THERMOSTAT
TERMINAL**

- # 8-----TO-----R (BOTTOM)
- #10-----TO-----B (LEFT SIDE)
- #11-----TO-----B (RIGHT SIDE)
- # 9-----TO-----BURNER NEUTRAL

NOTE: For single stage plenum thermostats, do not wire terminal # 11.

NOTE: For wiring non-Shivvers 4 wire Hi-Lo plenum thermostat circuits, see page 42.

296 small circuitrol

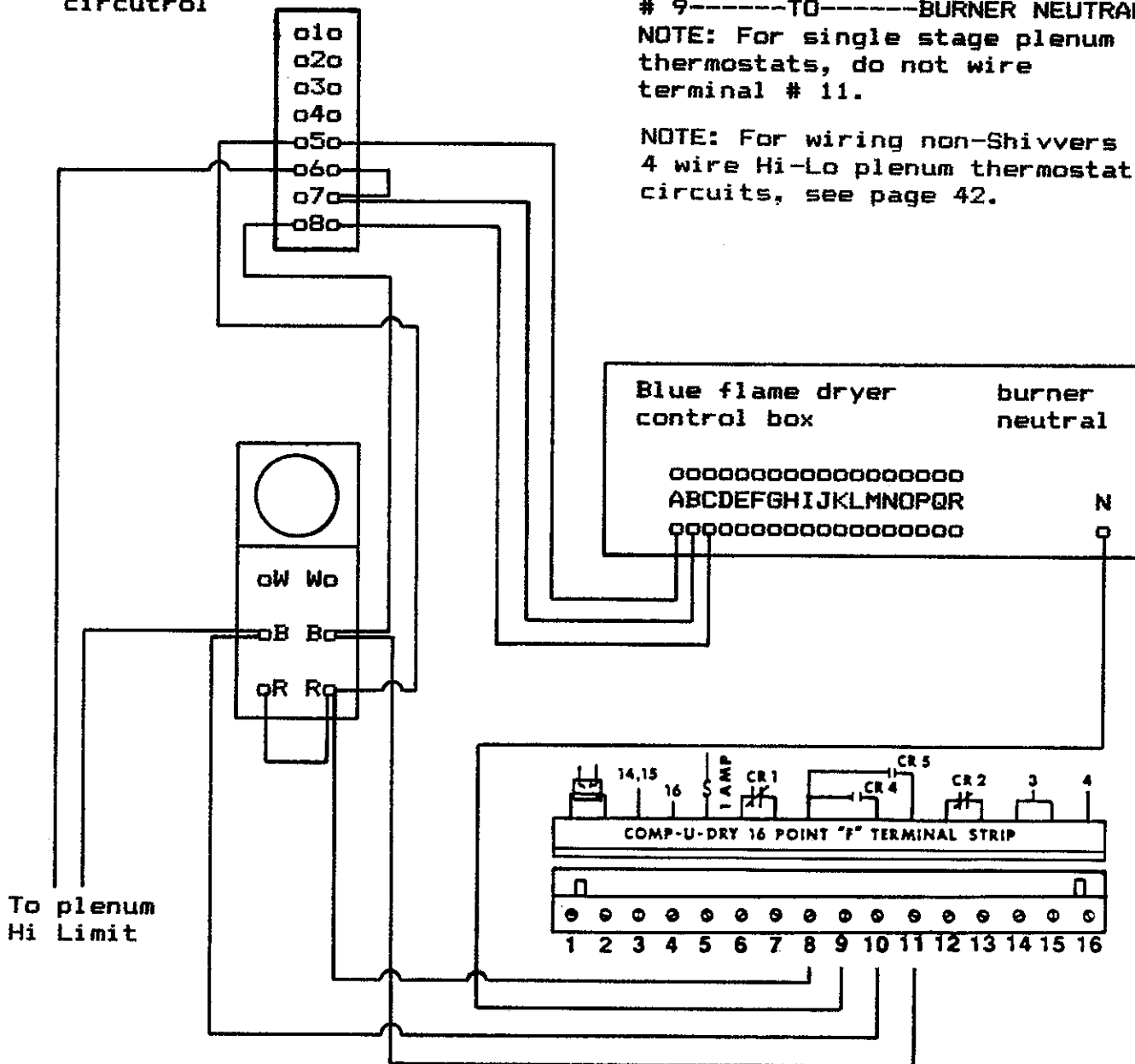

WIRING TO THE 1974-77 CIRCU-TROLS

To allow parallel operation of the Comp-U-Dry and the grain thermostat a relay will be required which should be mounted in the Circu-Trol.

WIRING THE COMP-U-DRY POWER AND NEUTRAL:

1. Connect the neutral terminal 1 of the Circu-Trol to neutral terminal 16 of the Comp-U-Dry 16 point "F" terminal strip.
2. Connect the Comp-U-Dry power input terminal 15 to the Circu-Lator "AUTO" switch terminal to which the indicator light is connected.

WIRING THE CIRCU-TROL CONTROL RELAY:

1. Mount the 2 pole relay in any convenient location in the Circu-Trol control box.
2. Remove the wire from the grain thermostat terminal "W" and connect it to the "N.O." relay terminal.
3. Remove the wire from the grain thermostat terminal "B" and connect it to the "N.C." relay terminal.
4. Connect a wire from the grain thermostat power source terminal "R" to the "Common" relay terminal.
5. Connect a wire from terminal "W" of the grain thermostat to the coil of the relay. Connect the other terminal of the relay coil to neutral terminal 1 in the Circu-Trol.
6. Connect a discharge auger control wire from the Comp-U-Dry terminal 5 to the grain thermostat terminal "W".

WIRING THE CONTINUOUS FLOW INTERRUPT:

1. Remove the other end of the wire which is attached to terminal 2 of the Time Delay Unit relay and connect it to terminal 13 of the Comp-U-Dry. Remove the jumper between Comp-U-Dry terminals 13 and 14.
2. Connect terminal 12 of the Comp-U-Dry to terminal 4 of the Circu-Trol.

WIRING THE BURNER:

1. Connect terminal 8 of the Comp-U-Dry to terminal "R" of the plenum thermostat.
2. Connect terminal 9 of the Comp-U-Dry to the burner neutral.
3. Connect terminal 10 of the Comp-U-Dry to terminal "B" of the plenum thermostat. (For a 2 stage thermostat it should be on the left terminal "B").
4. For a 2 stage thermostat connect Comp-U-Dry terminal 11 to the Hi-fire or right hand "B" terminal of the plenum thermostat.
5. If the burner neutral is not the same as the Circu-Trol neutral, remove the jumper between terminals 4 and 9 of the Comp-U-Dry 16 point "F" terminal strip and wire the burner neutral to terminal 9.

For wiring non-Shivvers 4 wire Hi-Lo plenum thermostat circuits, see page 42.

Additional wiring will be required if a Grain Level Indicator is used. See pages 31 through 33.

1974-77 CIRCUL-TROL WITHOUT GRAIN LEVEL INDICATOR

BEFORE
BOLD WRES NEED TO BE CHANGED

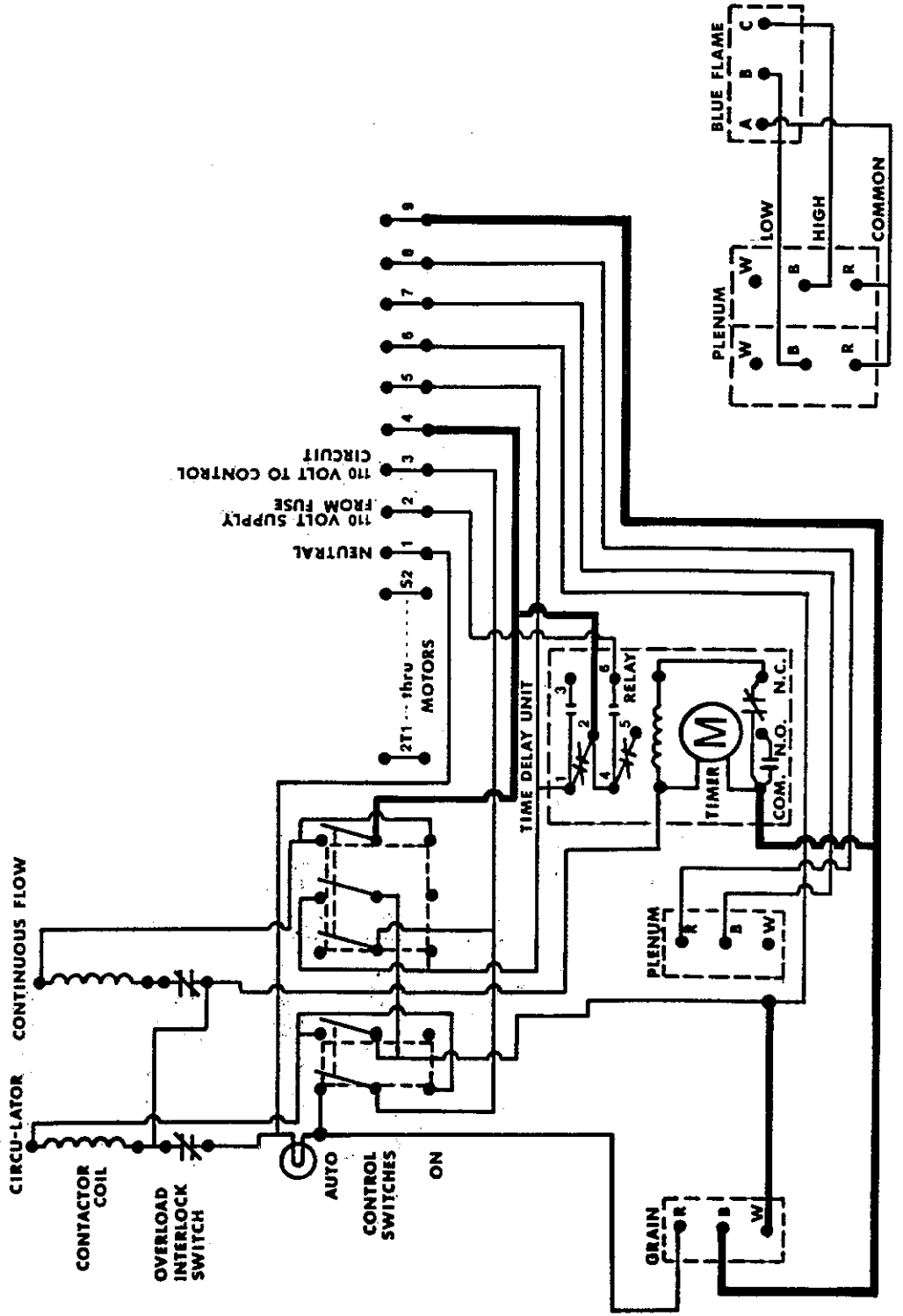

THERMOSTATS:
R-B OPENS ON
HEAT RISE
R-W CLOSSES ON
HEAT RISE
R: COMMON
B: HEAT
W: COOL

2 STAGE THERMOSTAT WIRING

1974-77 CIRCU-TROL WITHOUT GRAIN LEVEL INDICATOR

AFTER

BOLD WIRES ARE FINAL CONFIGURATION

NOTE: ○ THIS SYMBOL INDICATES TERMINAL NUMBER ON COMP-U-DRY 16 POINT "F" TERMINAL STRIP.

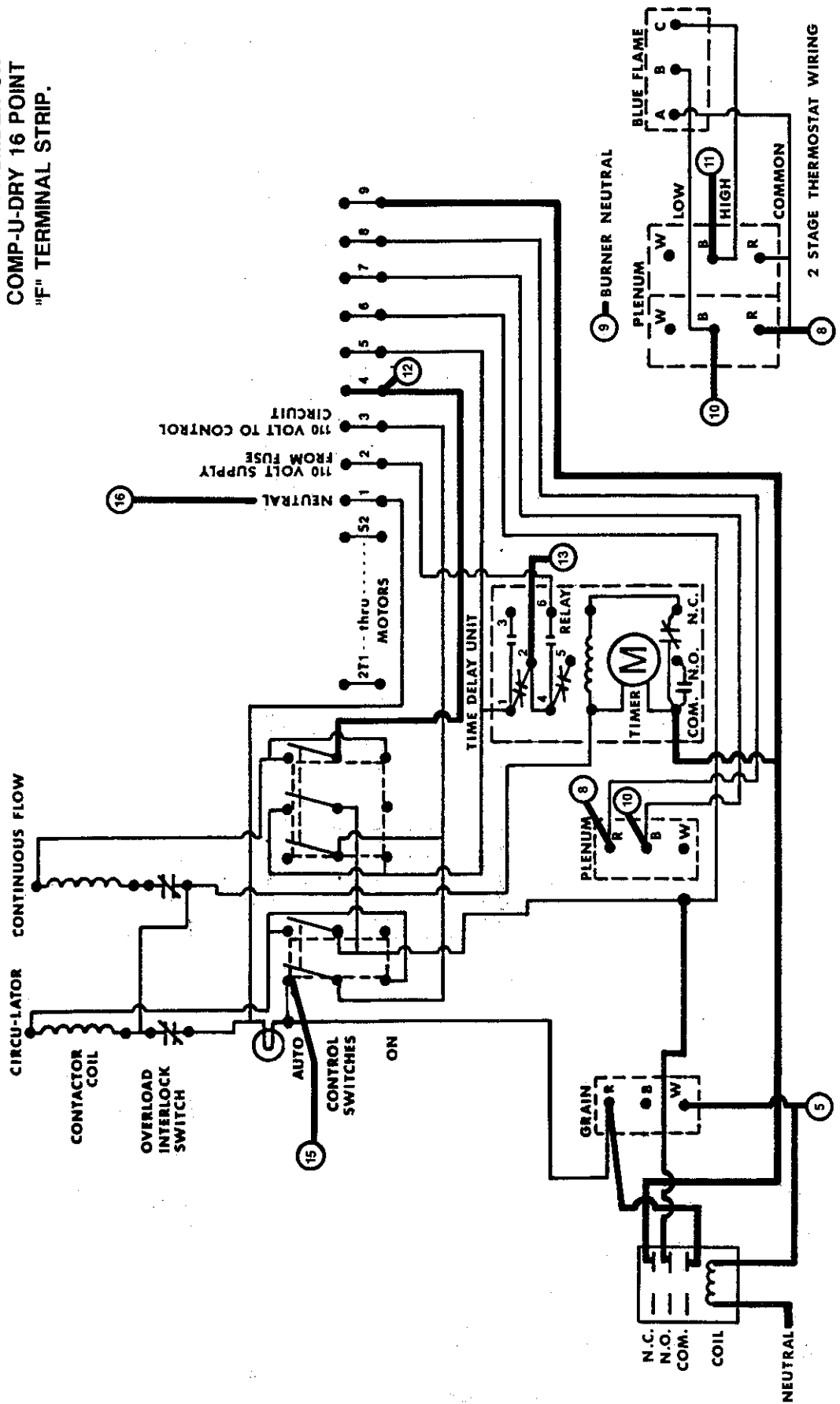

1974-77 CIRCULO-TROL WITH GRAIN LEVEL INDICATOR

BEFORE

BOLD WIRES NEED TO BE CHANGED

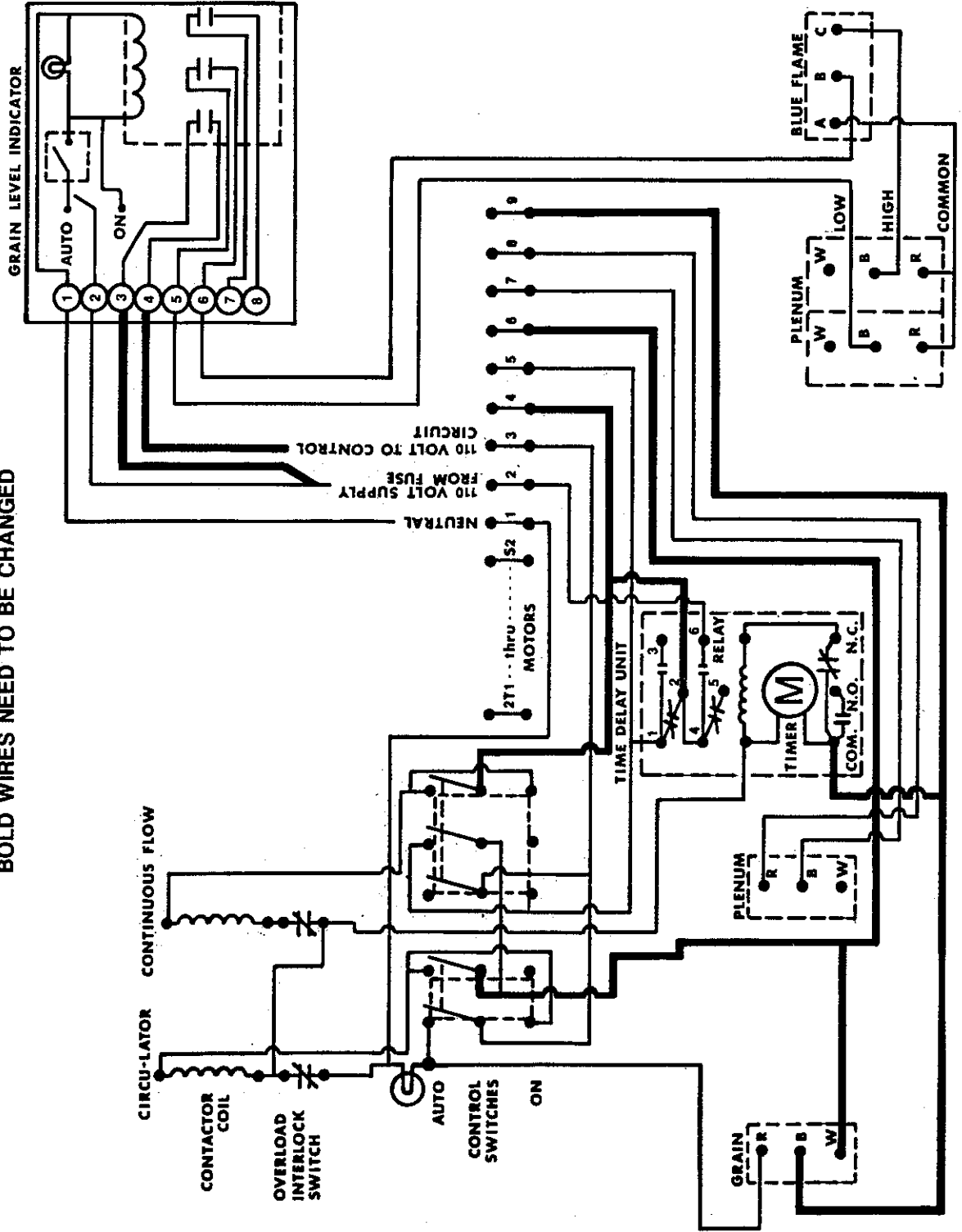

1974-77 CIRCUL-TROL WITH GRAIN LEVEL INDICATOR

AFTER

BOLD WIRES ARE FINAL CONFIGURATION

NOTE: ○ THIS SYMBOL INDICATES TERMINAL NUMBER ON COMP-U-DRY 16 POINT "F" TERMINAL STRIP.

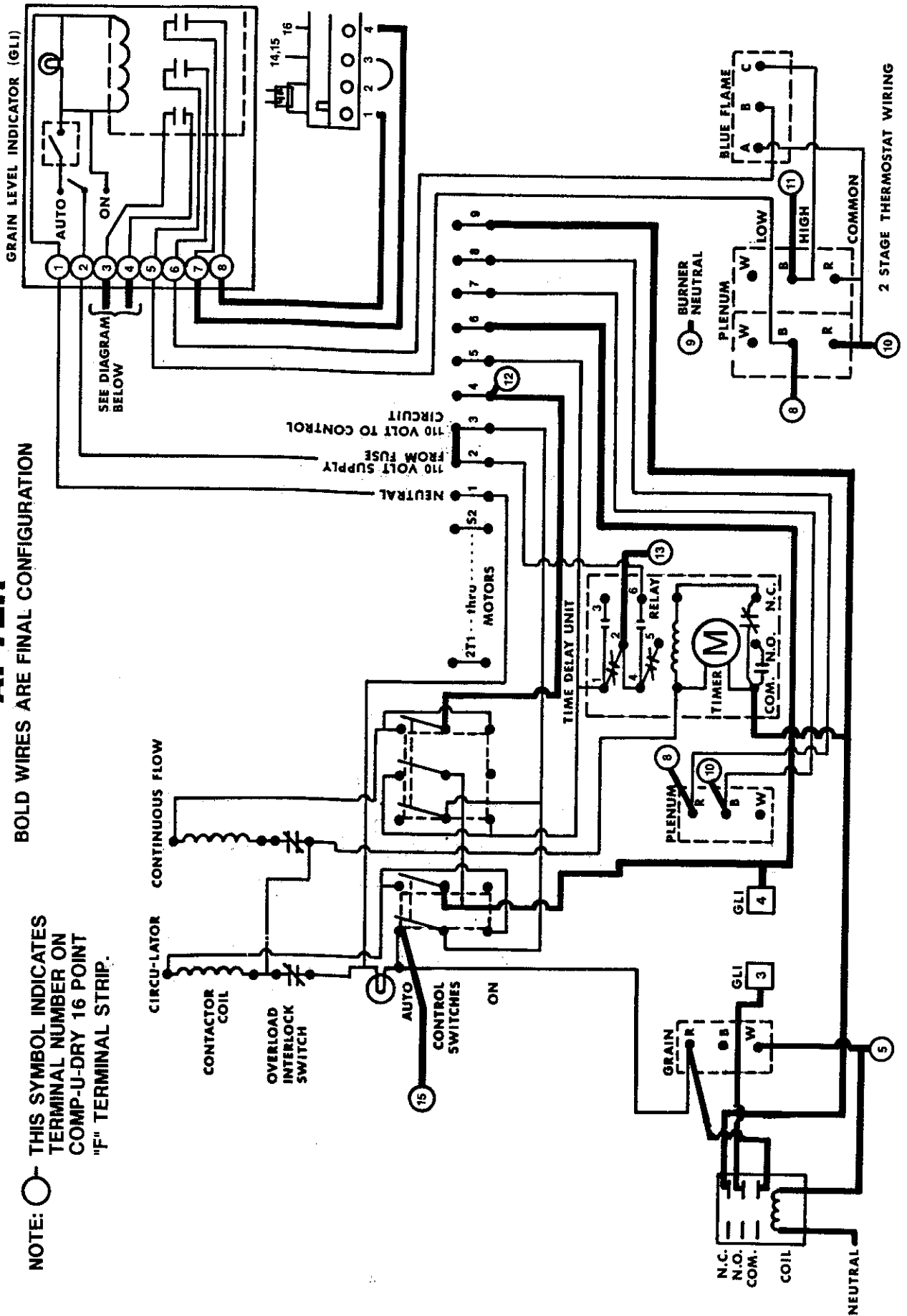

**IF A GRAIN LEVEL INDICATOR (GLI) IS USED
THE FOLLOWING WIRING IS REQUIRED**

1. Remove the wires between the GLI terminals 3 and 4 and the circuitrol. If there is a jumper between the GLI terminal 2 and 3 it should be removed. The wire between GLI terminal 2 and the Circu-Trol terminal 2 should remain.
2. Install a jumper between terminal 2 and 3 of the Circu-Trol.
3. Remove the wire on the Grain thermostat terminal "W" which runs to the "AUTO" switch and connect it to the GLI terminal 4.
4. Connect the Grain thermostat terminal "W" to terminal 3 of the GLI.
5. Remove the jumper between Comp-U-Dry terminal 1 and 4.
6. Connect Comp-U-Dry terminal 1 to GLI terminal 7.
7. Connect Comp-U-Dry terminal 4 to GLI terminal 8.

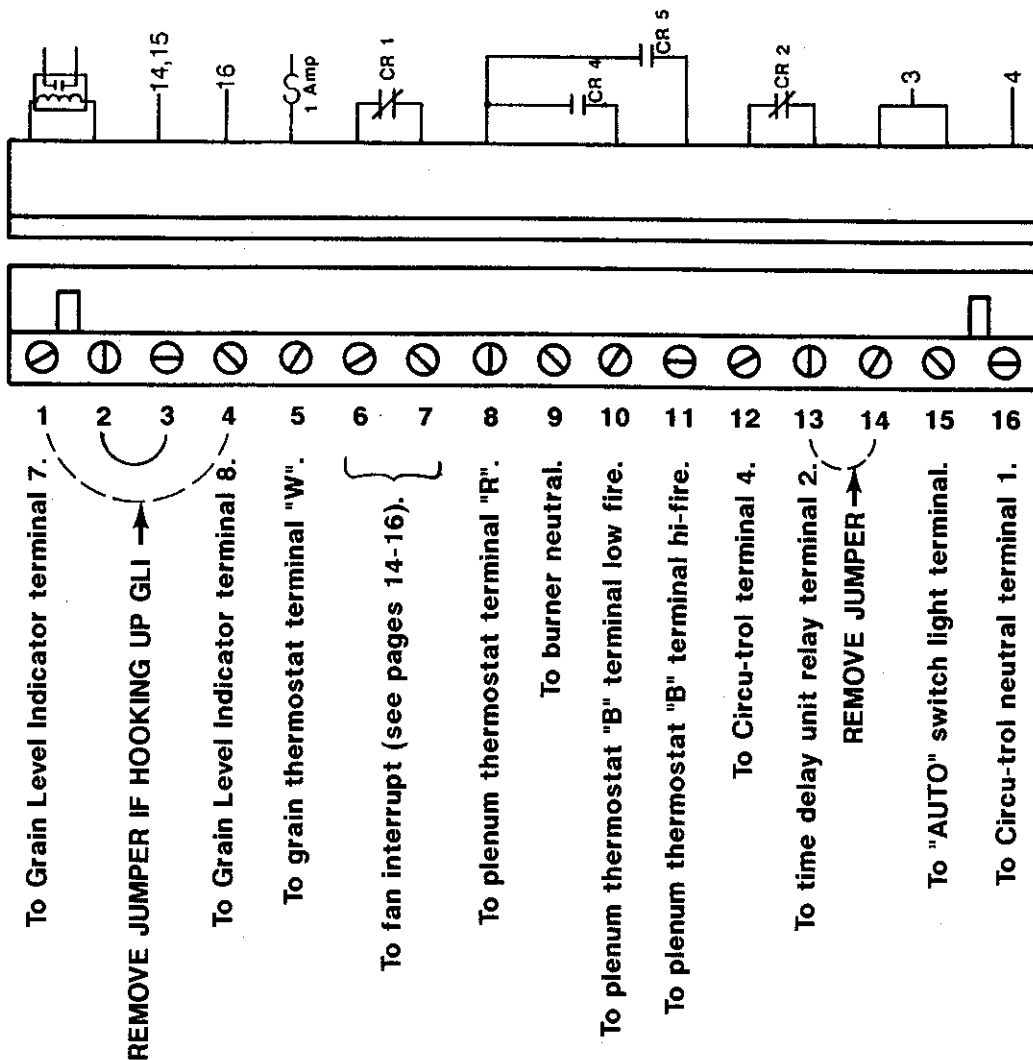

WIRING THE NECO DELUXE CONTROL PANEL
230 VOLT SINGLE PHASE

THE COMP-U-DRY OPERATES ON AND CONTROLS 120 VAC POWER SUPPLY. BE SURE THAT IT IS NOT CONNECTED TO ANY 230 VOLT SUPPLY.

The Comp-U-Dry functions as a parallel system to the NECO DELUXE CONTROL PANEL. Either the NECO DELUXE CONTROL PANEL or the Comp-U-Dry will control the grain drying operation. Control is determined by the grain and plenum (burner) thermostat settings.

To allow parallel operation, a relay must be installed in the NECO DELUXE CONTROL PANEL. If your system is equipped with a LOW GRAIN SHUT-OFF, you will also need to install an additional 2 pole relay to operate this line. This relay must have a voltage rating capable of accomodating the voltage from your power source. Mount this relay in a convenient location close to the LOW GRAIN SHUT-OFF switch. DO NOT mount this relay in the Comp-U-Dry panel.

SEE THE DETAIL DRAWINGS SHOWING HOW THESE CONNECTIONS ARE MADE TO THE RELAYS, THE COMP-U-DRY, AND HOW THE FINAL WIRING SHALL APPEAR.

NECO DELUXE 230 VOLT SINGLE PHASE RELAY WIRING for operation of the grain thermostat a relay is required to avoid "feed back" on the on the machine control line.

- 1) Mount a 2 pole relay in any convenient location in the NECO DELUXE CONTROL PANEL.
- 2) Connect a wire from the grain (Circu-flow) thermostat "R" location to the "N.O." relay terminal.
- 3) Connect a wire from the grain (Circu-flow) thermostat "W" location to the "common" relay terminal.
- 4) Connect a discharge auger control wire from terminal 5 of the Comp-U-Dry 16 point "F" terminal strip to the relay coil terminal. Connect a wire from the other relay coil terminal to the NECO DELUXE control panel.

NECO CONTINUOUS FLOW SWITCH REWIRING

- 1) Remove the red wire from between CF174 switch and CF206 switch.

NECO LOW GRAIN SHUT-OFF REWIRING

- 1) Remove the wires that connect the LOW GRAIN SHUT-OFF switch to your plenum (burner) thermostat and the burner control box.

SEE THE DETAIL DRAWINGS SHOWING THESE CONNECTIONS BEFORE AND AFTER.

INTERCONNECTING COMP-U-DRY
16 POINT "F" TERMINAL STRIP TO

* * * * *
*
* NECO DELUXE CONTROL PANEL *
* 230 VOLT SINGLE PHASE *
*
* * * * *

A relay should be field installed in the Neco Deluxe Control Panel to allow parallel operation of the Comp-U-Dry and the Neco Deluxe Control Panel. A second relay should be installed for operating the Low Grain Shutoff. Detail instructions for hook-up of each unit are given on the following pages.

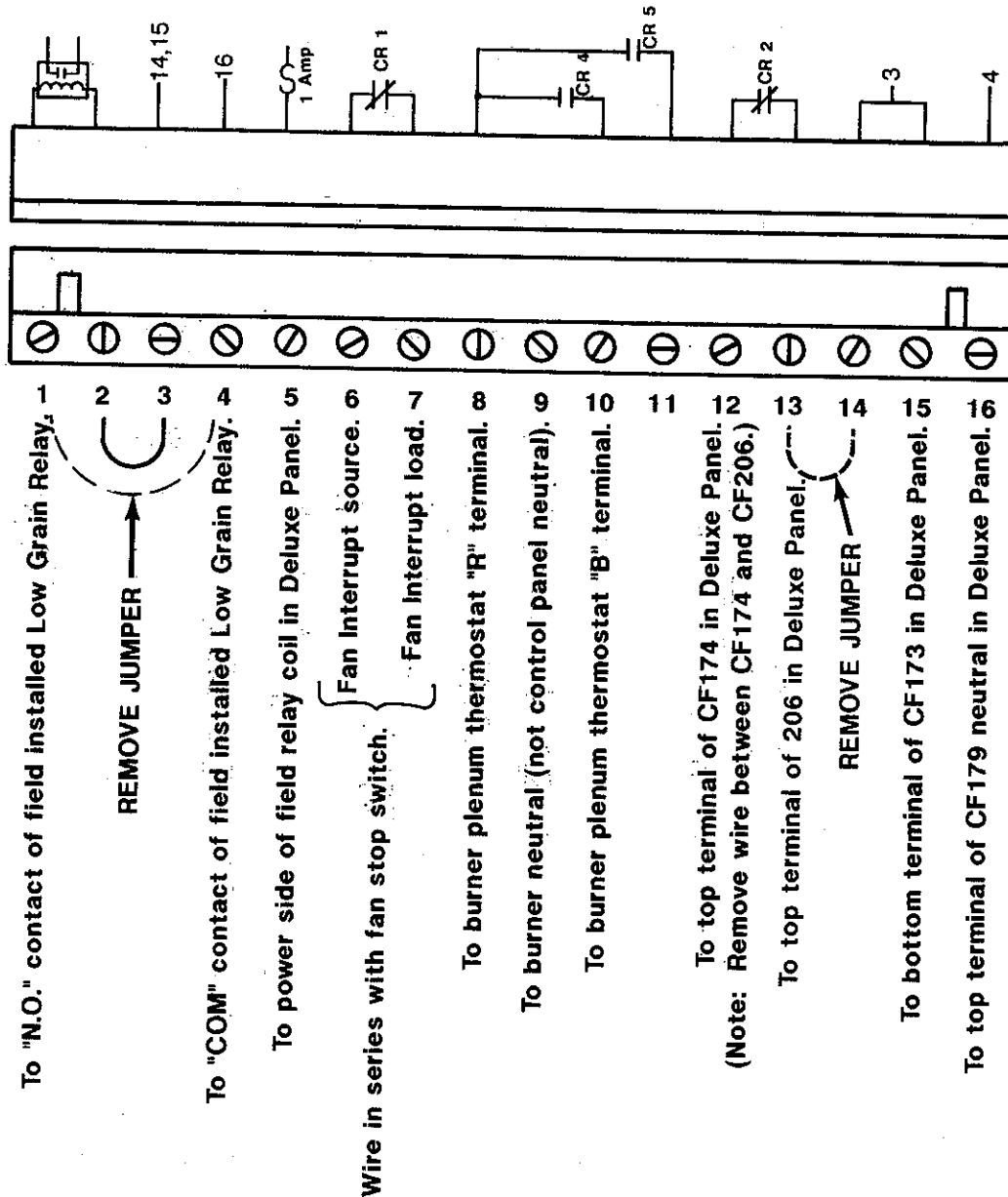

The Comp-U-Dry controls the burner thru connections to the Comp-U-Dry 16 point "F" terminal strip thru terminals 8 and 10.

NECO DELUXE

BEFORE

BOLD WIRE NEEDS TO BE CHANGED

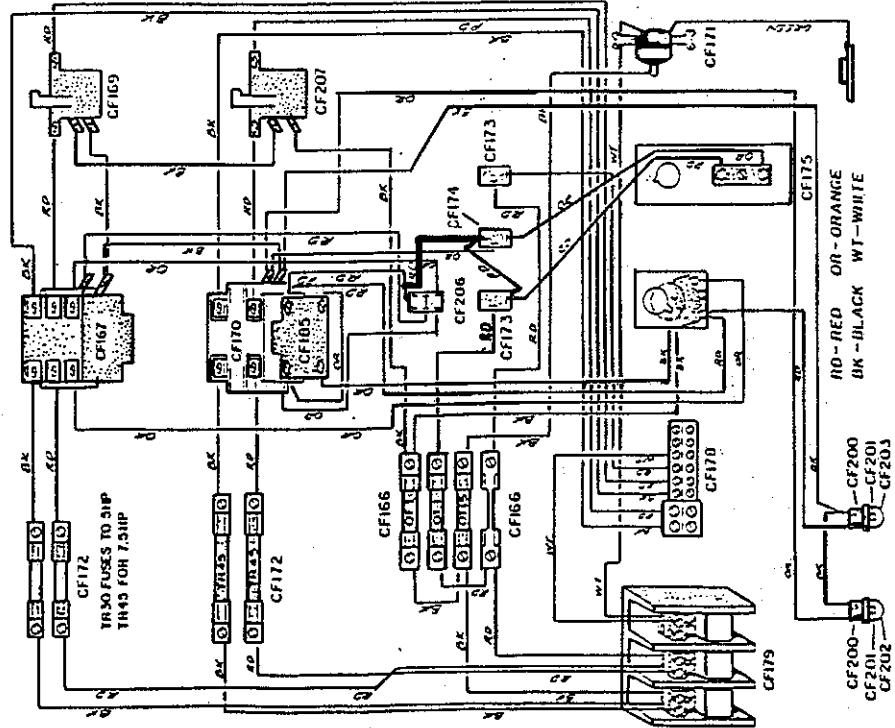

AFTER

BOLD WIRES ARE FINAL CONFIGURATION

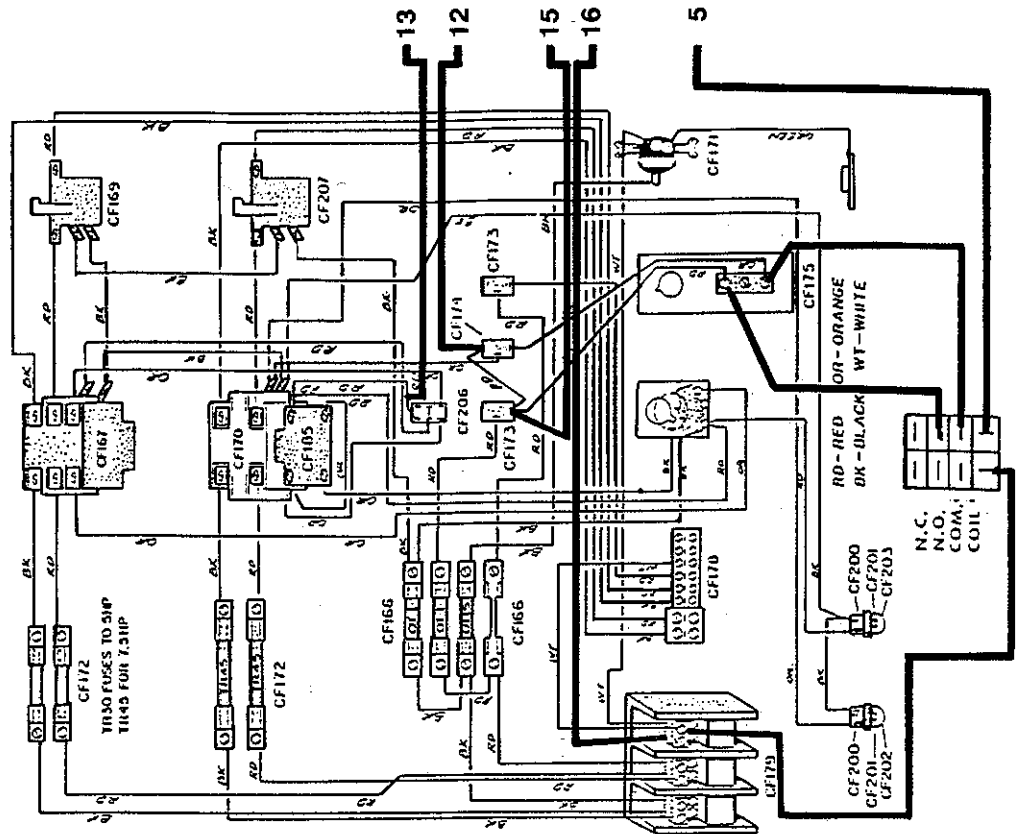

COMP-U-DRY 16 POINT "F" TERMINAL STRIP

NECO DELUXE WITH LOW GRAIN SHUT-OFF

BURNER THERMOSTAT

BEFORE

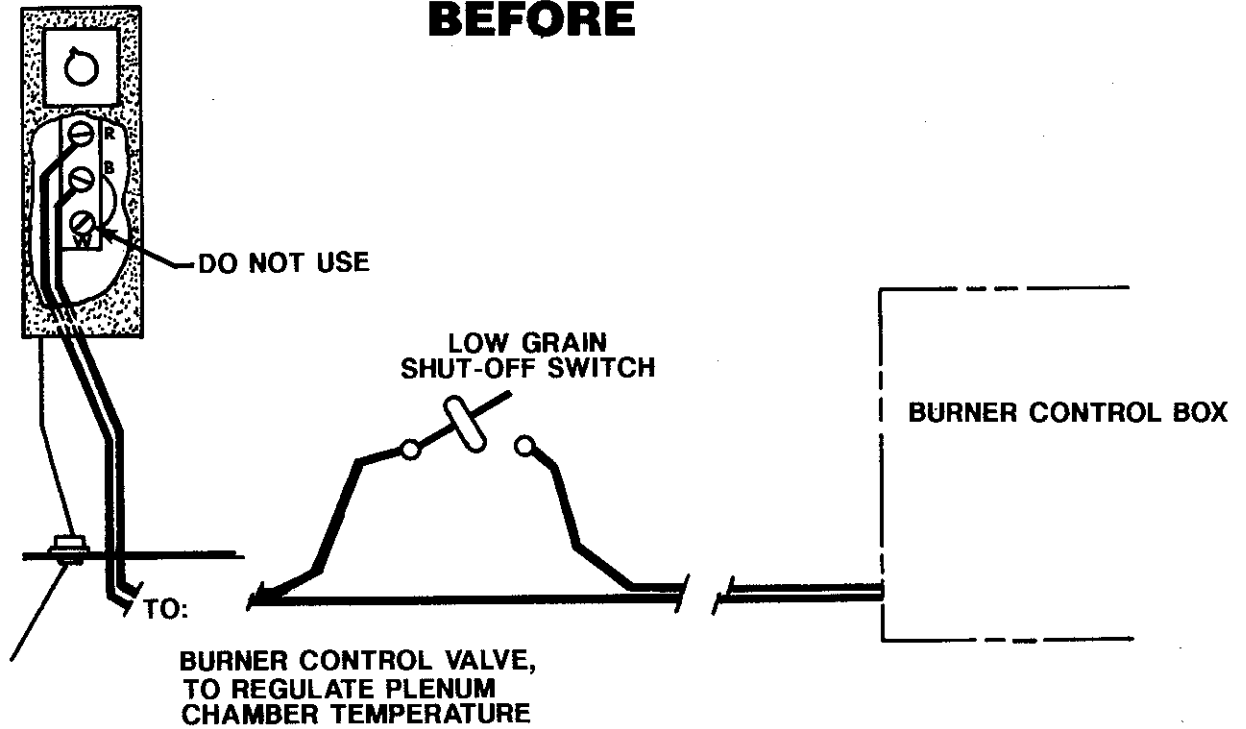

AFTER

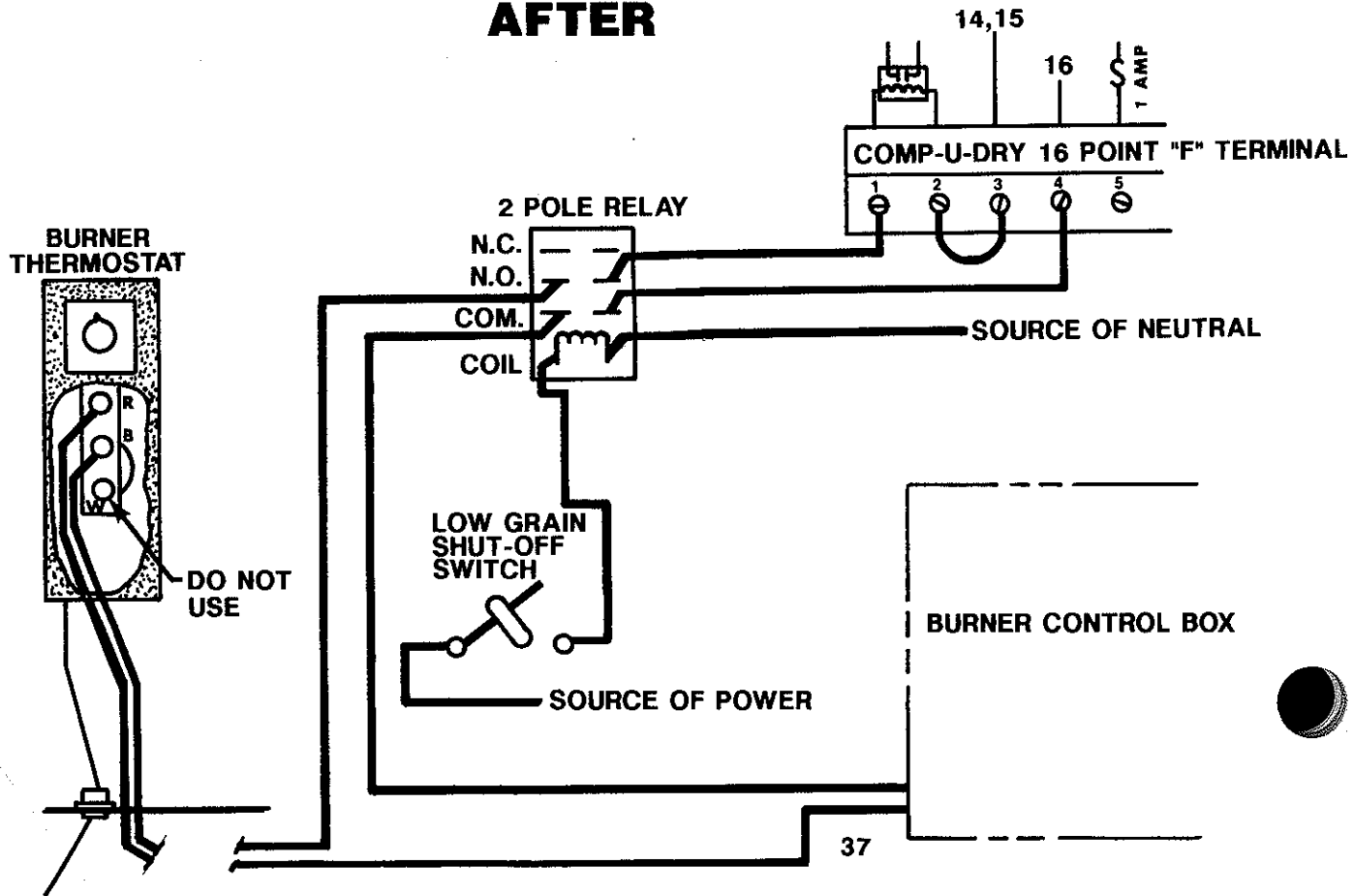

GENERIC WIRING INSTRUCTIONS
 (For Wiring into Control Panels Not
 Covered by any of the Preceding Instructions)

***** DO NOT USE ON 230 VOLT SYSTEMS *****

The Comp-U-Dry operates on, and controls only 120 Volt AC power. For use on 230 volt control systems, contact the factory.

The Comp-U-Dry functions as a parallel system to your existing control panel. Either your control panel or the Comp-U-Dry will control the grain drying operations. Control is determined by the grain and plenum (burner) thermostat setting.

TO WIRE THE 16 POINT "F" TERMINAL STRIP IN THE COMP-U-DRY

- 1) All units have the burner neutral wired to terminal #9.
- 2) The Comp-U-Dry is provided with 120 VAC power from the load side of the automatic switch of your drying machine auger (ie. Circu-Lator Auto Switch). This source is wired to terminal #15 in the Comp-U-Dry. A neutral wire must also be provided that connects to terminal #16 in the Comp-U-Dry.

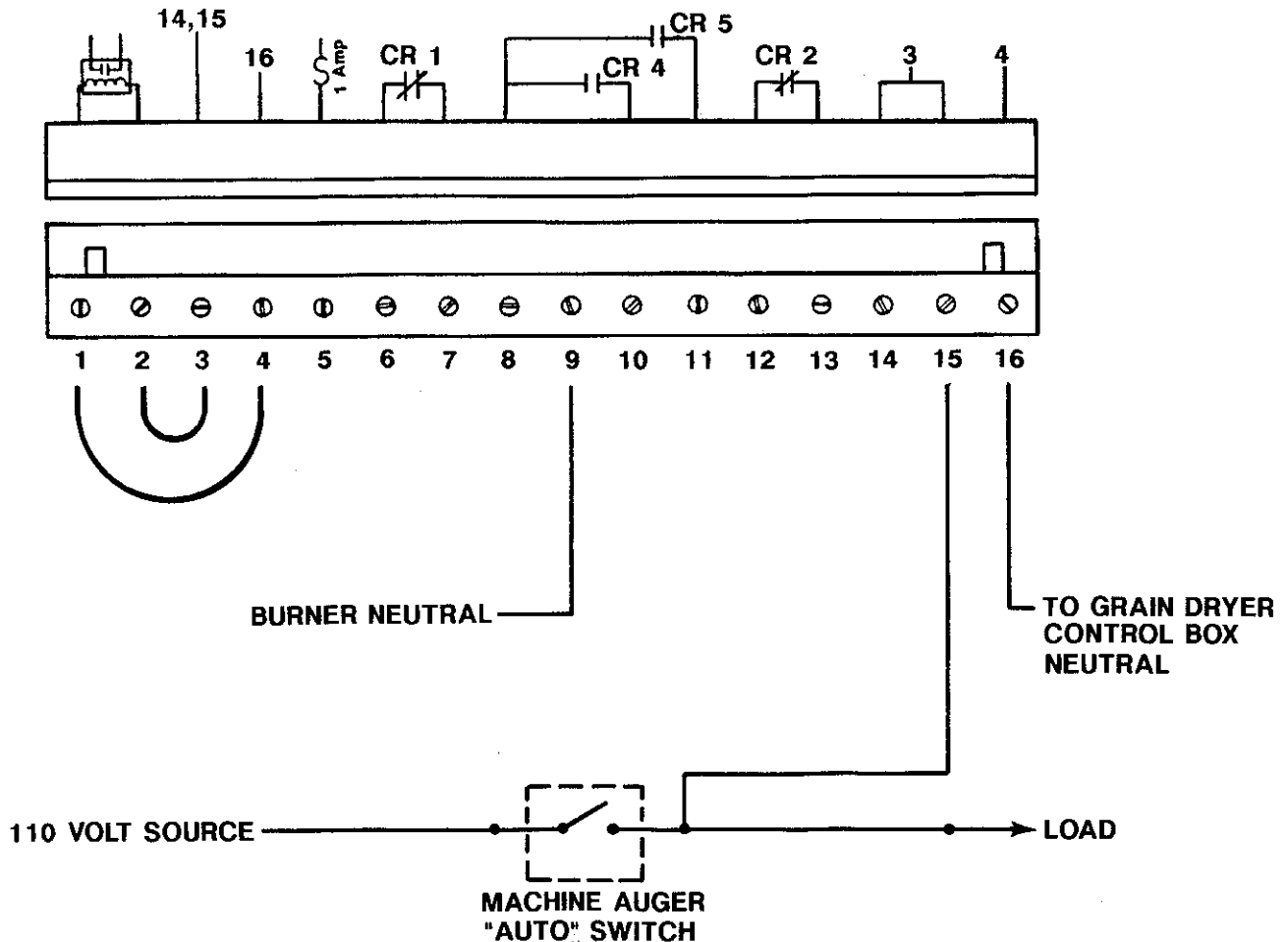

WIRING THE LOW GRAIN SHUTOFF

The Comp-U-Dry is provided with a sensor between terminals #1 and #2 which allows the detection of a low grain shut-off condition. If a low grain shut-off is not going to be used, terminal 2 must be jumpered to terminal 3 and terminal 1 must be jumpered to terminal 4.

UNITS WITH OUT LOW GRAIN SENSOR

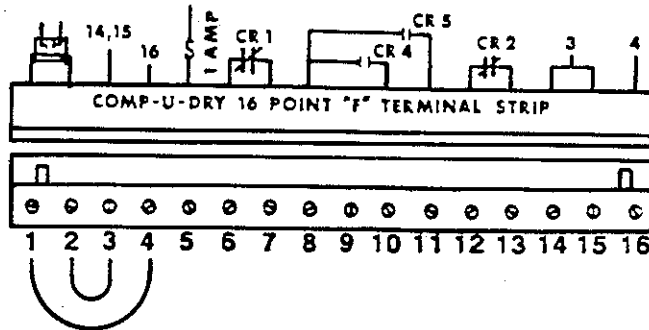

On units with a low grain shut-off switch an additional 2 pole relay is required. The low grain shut-off switch needs to be converted to a power line and used to control the coil of the two pole relay. The line which the low grain shut-off switch previously controlled needs to be wired to one set of the normally open and common contacts of the two pole relay. The other set of normally open and common contacts should be hooked to terminals #1 and #4 in the Comp-U-Dry. A jumper must be between terminals #2 and #3.

UNITS WITH LOW GRAIN SENSOR

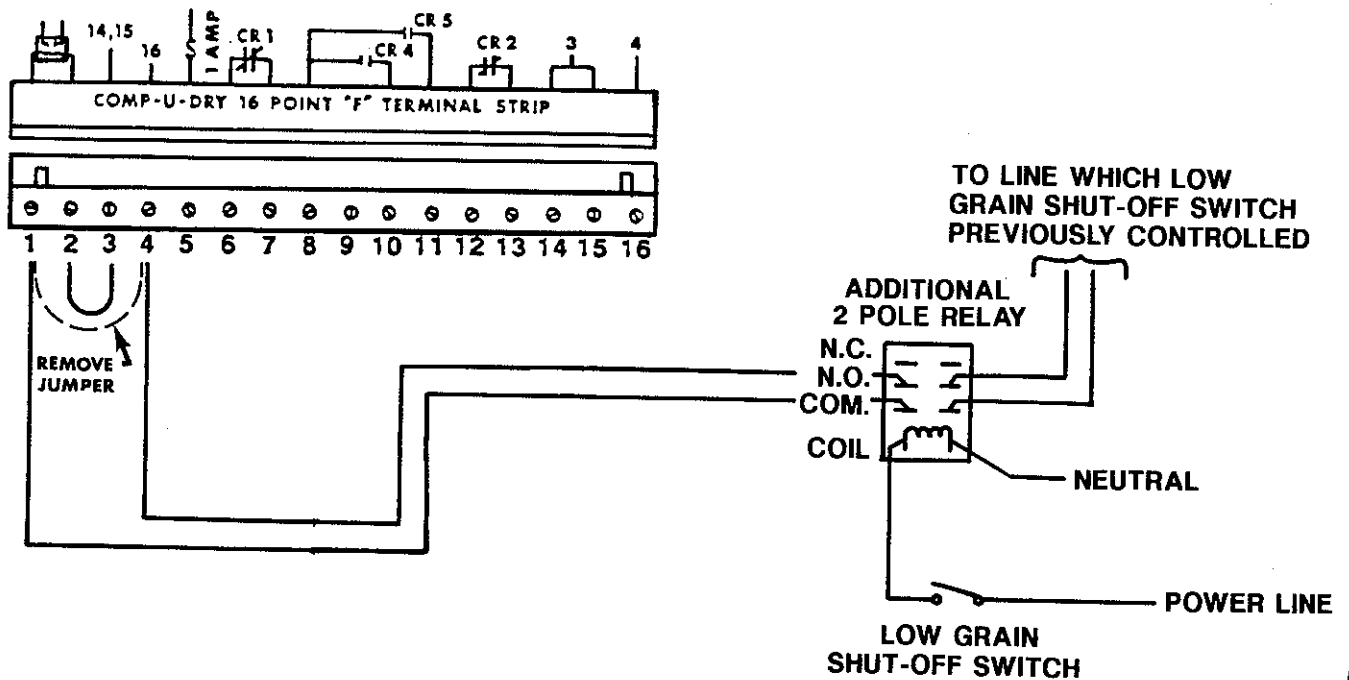

The above hookup is based on the low grain shutoff switch contacts opening when the bin is out of grain.

WIRING THE FAN INTERRUPT CIRCUIT

The fan interrupt circuit is used to shut the fans off one hour after the low grain shut-off switch is opened. On units without a low grain shut-off switch, these connections are not necessary. To wire this feature, the power line going to the coil of the fan motor contactor should be broken and wired to terminals #6 and #7 of the Comp-U-Dry.

FAN INTERRUPT CIRCUIT

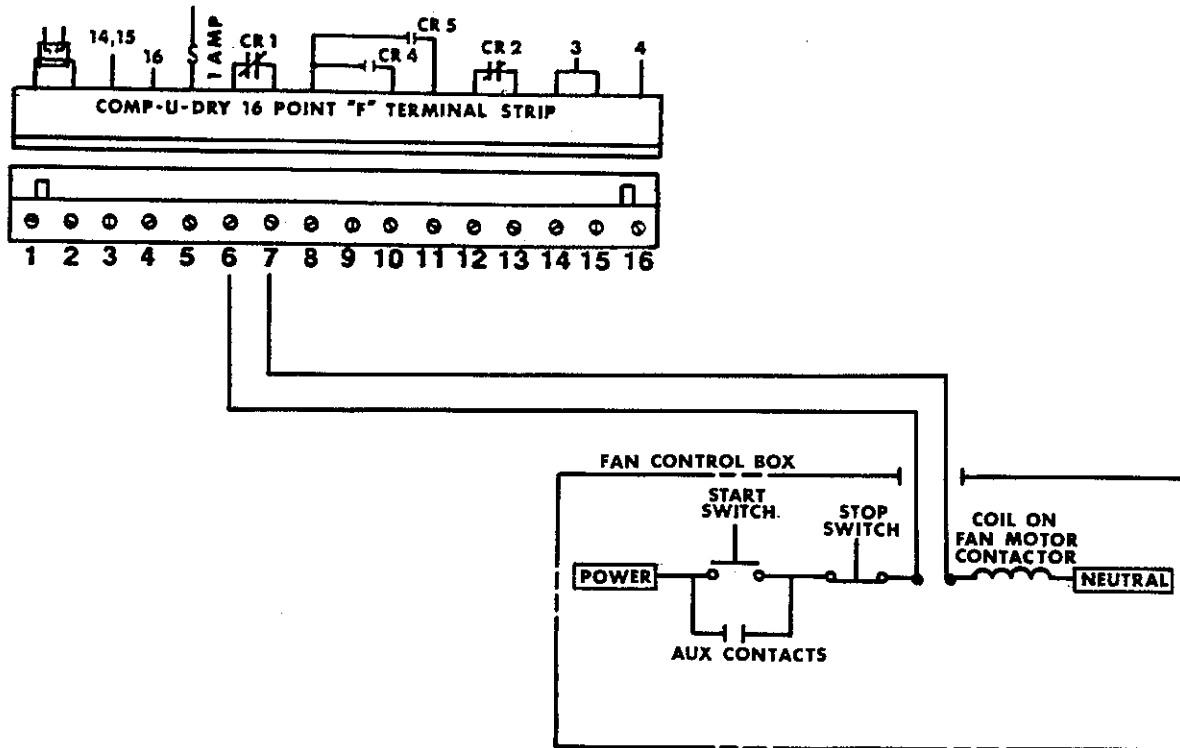

WIRING 4 WIRE DUAL STAGE THERMOSTATS

Due to the way the safety circuits function, some dual stage thermostats are hooked up with the low fire and hi fire current sources isolated from each other. In this case a relay will be required to maintain the isolation. Wire Comp-U-Dry terminals 8 and 10 in parallel to the wires in the primary or low fire side of the thermostat. Wire Comp-U-Dry terminal 11 as the power source for the isolation relay. Wire one set of normally open relay contacts in parallel to the existing wires on the hi fire contacts of the thermostat.

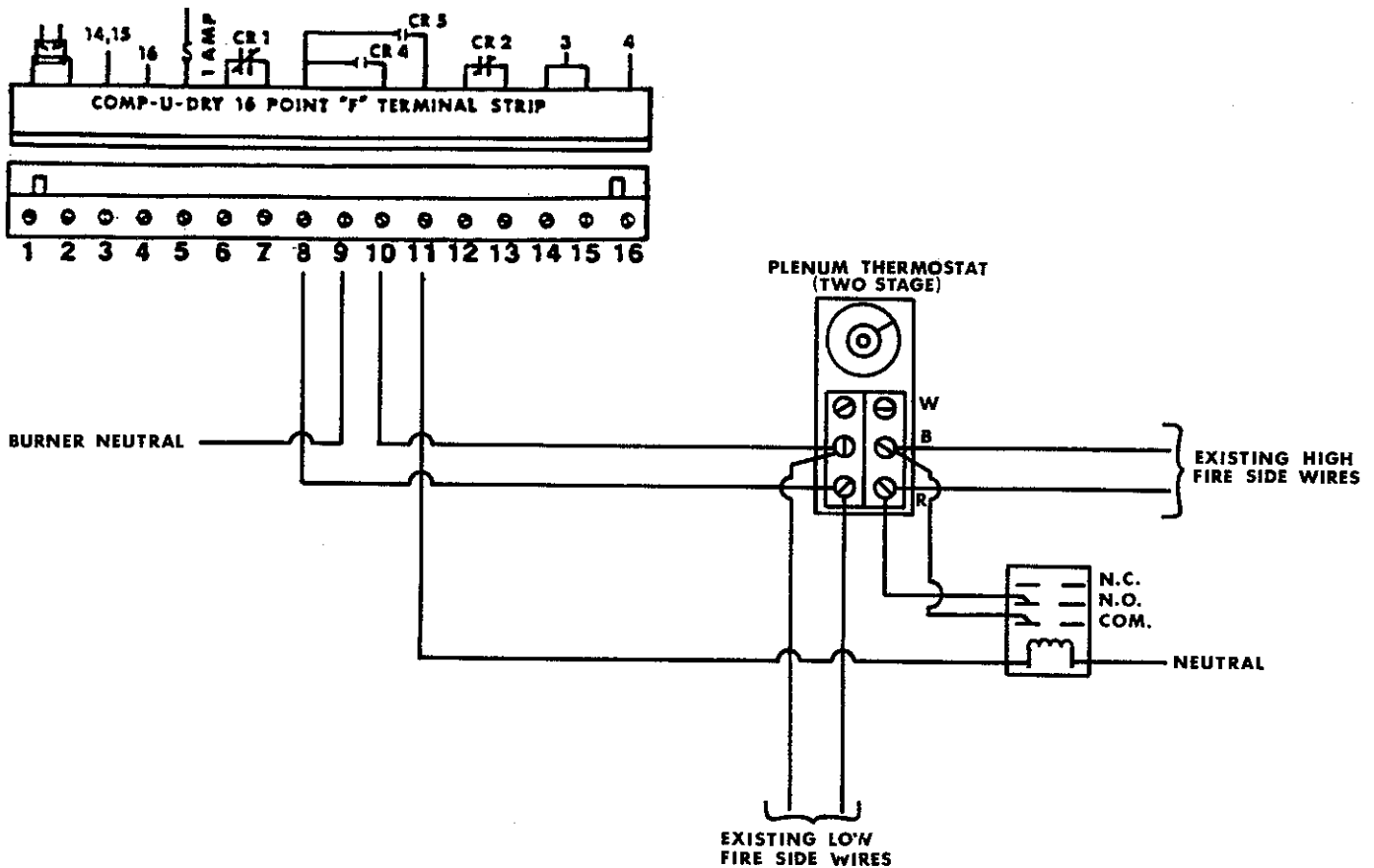

WIRING A MODULATING VALVE

The Comp-U-Dry can control modulating valves by interrupting the fuel flow to the modulating valve. Some burner circuitry will not allow the flame to be shut off without going into a "lock-out" situation. You must check the circuitry to insure the burner will re-ignite if the fuel flow is interrupted. IF BURNER DOES NOT RE-IGNITE THE Comp-U-Dry WILL NOT CONTROL THE MODULATING VALVE WITHOUT BURNER CIRCUIT MODIFICATION. Contact the burner manufacturer for changes needed to control the burner in an ON-OFF mode.

WIRING MACHINE DISCHARGE AUGER CONTROL

The machine auger control circuit turns the removal auger on and off by providing 110 volt power at terminal #5, of the Comp-U-Dry 16 point "F" terminal strip. Neutral is provided at terminal #4. To allow either the Comp-U-Dry or your current control panel to run the machine auger, a relay must be installed parallel to the existing grain temperature thermostat. Mount this relay in your existing control panel. (DO NOT MOUNT IN COMP-U-DRY). Wire the coil to Comp-U-Dry terminals #5 and #4. Wire one set of normally open contacts to the grain thermostat so it runs parallel with the existing wires.

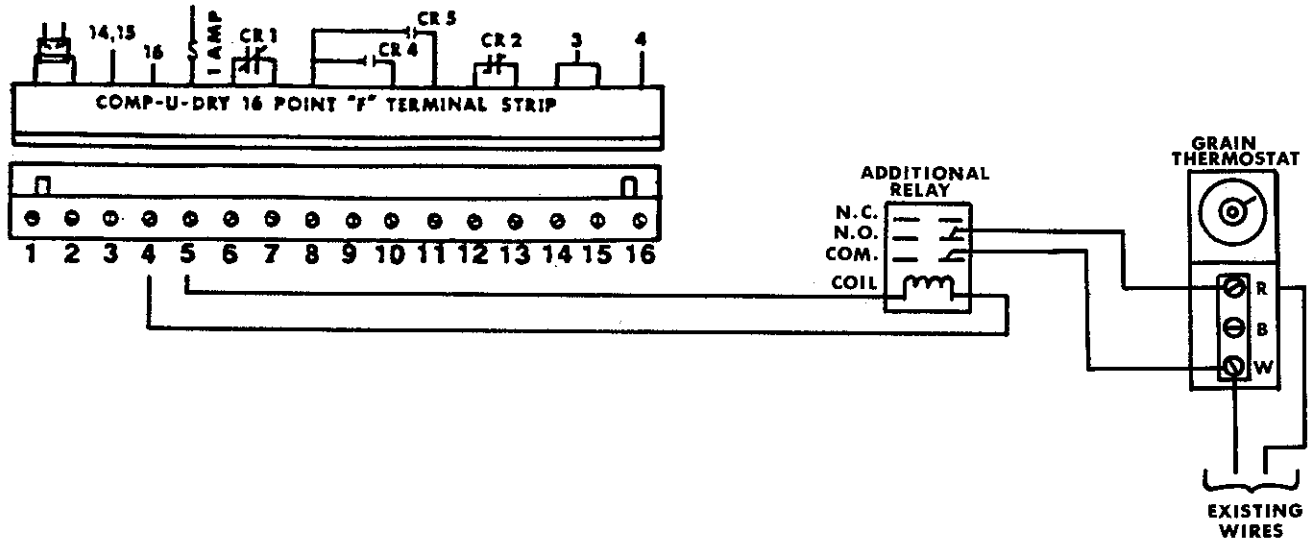

WIRING THE TRANSFER AUGER CONTROL

The transfer auger control turns the continuous flow and roof augers on and off by opening and closing contacts within the Comp-U-Dry panel between terminals #13 and #12. Remove the jumper wire between terminal #13 and #14 in the Comp-U-Dry. The coil of the transfer auger motor contactor must be broken and wired to terminals #13 and #12 in the Comp-U-Dry.

NOTE: On Dri-Flo type units, this circuit should not be used.

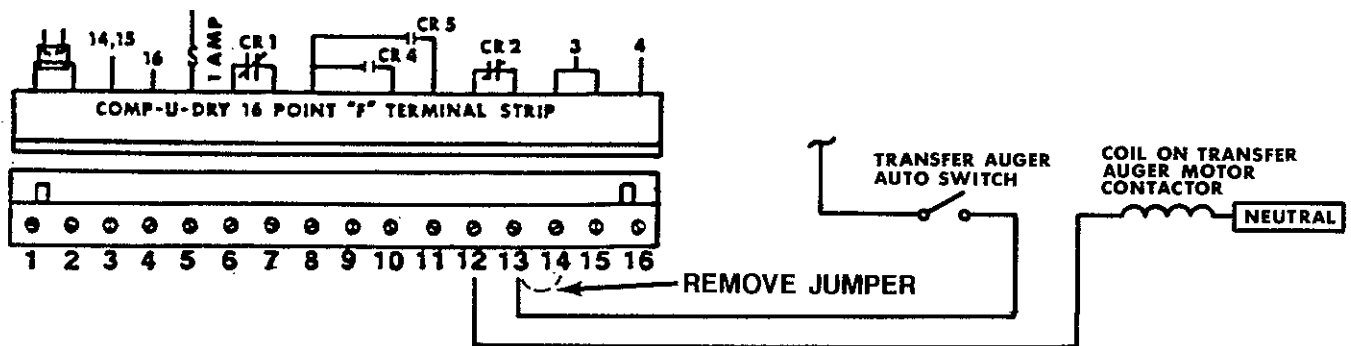

For any wiring which isn't covered or understood in this manual, please call the factory for instructions.

Shivvers Inc. 614 W. English Corydon, Iowa 50060

AREA CODE 515 872-1005