



# INSTALLATION ASSEMBLY INSTRUCTIONS

for

**6" AUGER 8" DOWN SPOUT**

423-320-001A Angled Kit  
&  
423-321-001A Straight Kit

*SHIVERS INCORPORATED  
CORYDON, IOWA USA  
(515) 872-1005*

**P-11079**

AUGUST 1995



# SAFETY

The operator of this machinery must assume the responsibility for his own safety, and that of those who are working with him. He must also make sure that the equipment was installed properly. Factors that contribute to the overall safety of operation are: proper use, maintenance, and frequent inspection of the equipment. All of these are the operator's responsibility.

If any items covered in this manual are not completely understood, or there is a concern with the safety of the product, contact Shivvers Incorporated at the address shown on the front page.

Shivvers is genuinely interested in providing the safest practical equipment to our customers. If you have a suggestion which you believe will enhance the safety of this product, please write us and let us know.

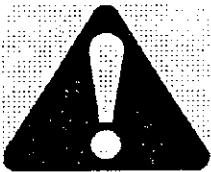

TAKE NOTE ANYTIME THIS SYMBOL APPEARS.  
YOUR SAFETY, AND THAT OF PERSONS AROUND  
YOU IS AT STAKE.

Anytime you are working with your drying unit, be sure to observe these common sense rules:

- 1). All units must be equipped with a main disconnect switch in close proximity to the grain bin's entry door. It must have the capability of being locked into the OFF position. Disconnect and LOCK OFF all electrical power before conducting any inspection, maintenance, repair, adjustment, or cleaning of the drying and transferring system. When you must have the electrical power on to troubleshoot equipment, do it from a safe distance, and always outside the bin.
- 2). Keep the bin entrances locked at all times. If entering the bin take the lock off the bin entrance and place it on the main disconnect before opening the bin entrance. Never enter the drying bin unless all power is disconnected and locked off.

- 3). Always keep all shields and guards in place. If shields or guards must be removed for inspection or maintenance, make sure power is disconnected and locked off. Replace all shields and guards before turning the power back on.
- 4). Do not turn the power on without being sure everyone is clear of all the drying and transferring equipment.
- 5). Make sure that all decals are in place and are easily readable. Do not operate the equipment with missing or illegible decals. If replacements are needed, contact Shivers Incorporated or your dealer.
- 6). Prior to use, inspect all equipment to insure that it is in good operating condition. Do not operate with missing, damaged, or worn parts.
- 7). Metal edges can be sharp. Wear protective clothing and handle equipment and parts with care.
- 8). Keep all children and bystanders away at all times.
- 9). If ascending the bin ladder and/or performing maintenance on the top of the bin, take precautions to prevent accidental falls. It is suggested that when on top of the bin a safety harness or other safety device be used.
- 10). Periodically review all operating and safety manuals with any personnel working with this equipment. Always train new employees before they operate the drying equipment. Insist that they read and understand the operating and safety manuals.

**DON'T TAKE CHANCES!**

**SLOW DOWN AND DO IT RIGHT!**

**AUTOMATIC CONTROLS CAN START EQUIPMENT AT ANY TIME!**

**ACCIDENTS ARE FOREVER!**

## ASSEMBLING THE DOWN SPOUT

- 1). The 6" Auger 8" Down Spouts are designed for use with the Super Hopper(263B-001A & 263C-001A) as a means of transferring grain from your 6" transfer auger to the top 8" inlet of the Super Hopper. To assemble the down spout locate the 8" Inlet Weldment(263-015W) from the parts box. Using (4) 5/16"x3/4" bolts, (4) Nyloc nuts and (4) 5/16" Flat washers; secure the down spout plates to the top of the Inlet Weldment, depending upon the type of Down Spout you received. The 423-320-001A Kit contains the Angled Down Spout Plates, one Left Hand (263-029P) and one Right Hand (263-030P). The 423-321-001A Kit contains the Straight Down Spout plates (263-031P), (2) identical pieces are used. See Figure on following page. Make sure that the flat washer is placed on the Inlet Weldment side when the bolts are tightened.
- 2). When installing the Down Spout on the Transfer Auger, make sure power is disconnected and LOCKED OFF!! If work occurs on the top of a bin, use of a safety harness and/or other safety equipment is recommended. Remove any existing down spout from the transfer auger. Place the Down Spout over the transfer auger opening, the edges of the Spout can rest either on the motor mount collars or on the transfer auger tube, which ever gives the best fit. Take the 6" Halfband, (4) 1"x5/16" bolts, (4) Nyloc nuts, and (4) 5/16" Flat Washers; and fasten the Down Spout to the Transfer auger. A bead of chalking may be placed between the auger tube and the Spout, for improved water resistance.
- 3). Use the 8" dia. by 18" long Flex Tube (263-022P) and the #8 Self Drilling Screws (F-1231) to connect the Down Spout outlet to the Super Hopper inlet.

423-320-001A  
6' AUGER 8" SPOUT  
ANGLED KIT

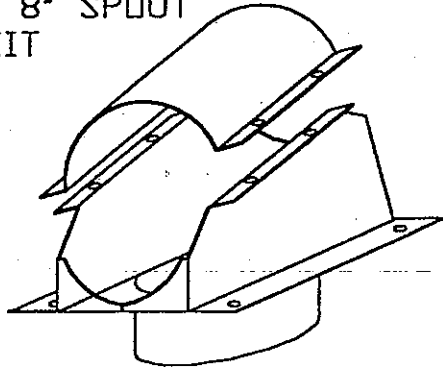

423-321-001A  
6' AUGER 8" SPOUT  
STRAIGHT KIT

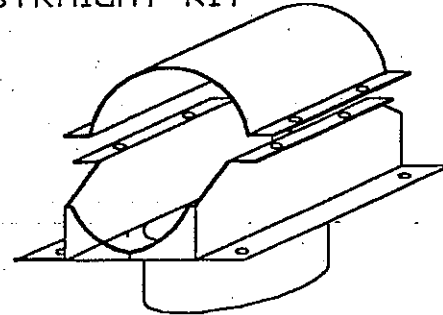

NO.	PART NO.	DESCRIPTION	QTY/ASSEM.
1	F-1015-15	5/16 x 1' BOLT	4
2	F-1009-02	5/16" FLAT WASHER	8
3	220-047P	6' HALFBAND	1
4	F-1005-02	NYLOC NUT	8
5	F-1546	5/16 x 3/4' BOLT	4
6	263-015W	8" INLET WELDMENT	1
7	263-029P	8" SPOUT ANGLED LH	1
8	263-030P	8" SPOUT ANGLED RH	1
9	263-031P	8" SPOUT STRAIGHT	2
10	263-022p	8" DIA. x 18" LONG FLEX	1
11	F-1231	#8 x 1/2" SELF DRILLING SCREWS	6

