

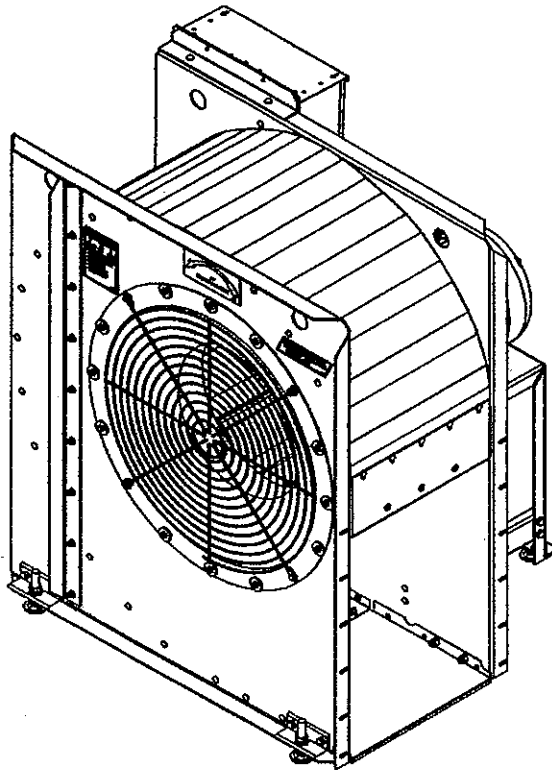

CENTRIFUGAL FAN



INSTALLATION & OPERATING INSTRUCTIONS

FOR MODEL:

1180-001A * 15 Hp, SINGLE PHASE

SHIVERS MANUFACTURING, INC.
614 W. English Street
Corydon, IA 50060
Ph. (641) 872-1005 ** Fax (641) 872-1593
www.shivers.com

P-12431
February 27, 2008

TABLE OF CONTENTS

	Page
INTRODUCTION	2
SAFETY INFORMATION	3-5
LOCATION OF SAFETY DECALS	6
OTHER IMPORTANT DECAL LOCATIONS	7
IDENTIFICATION OF PARTS	8-9
MECHANICAL INSTALLATION	10-14
* Drying Bin Layout	10-13
* C-Fan	14
ELECTRICAL INSTALLATION	15-17
INITIAL CHECKOUT	18
OPERATION	19
MAINTENANCE	20
TROUBLESHOOTING	21-22
SCHEMATIC	23

INTRODUCTION

COMPLETELY READ THIS MANUAL AND THE OPERATOR'S SAFETY MANUAL (P-10001) BEFORE INSTALLING OR USING THE SHIVVERS CENTRIFUGAL FAN.

This manual is intended for use with a Shivers Centrifugal fan connected to a Shivers Blue Flame II burner. The fan may be used with other manufacturer's burners, but care should be taken to insure proper hook-up.

The Shivers bolt together, galvanized, 15 Hp Centrifugal Fan was first put into production in 2007.

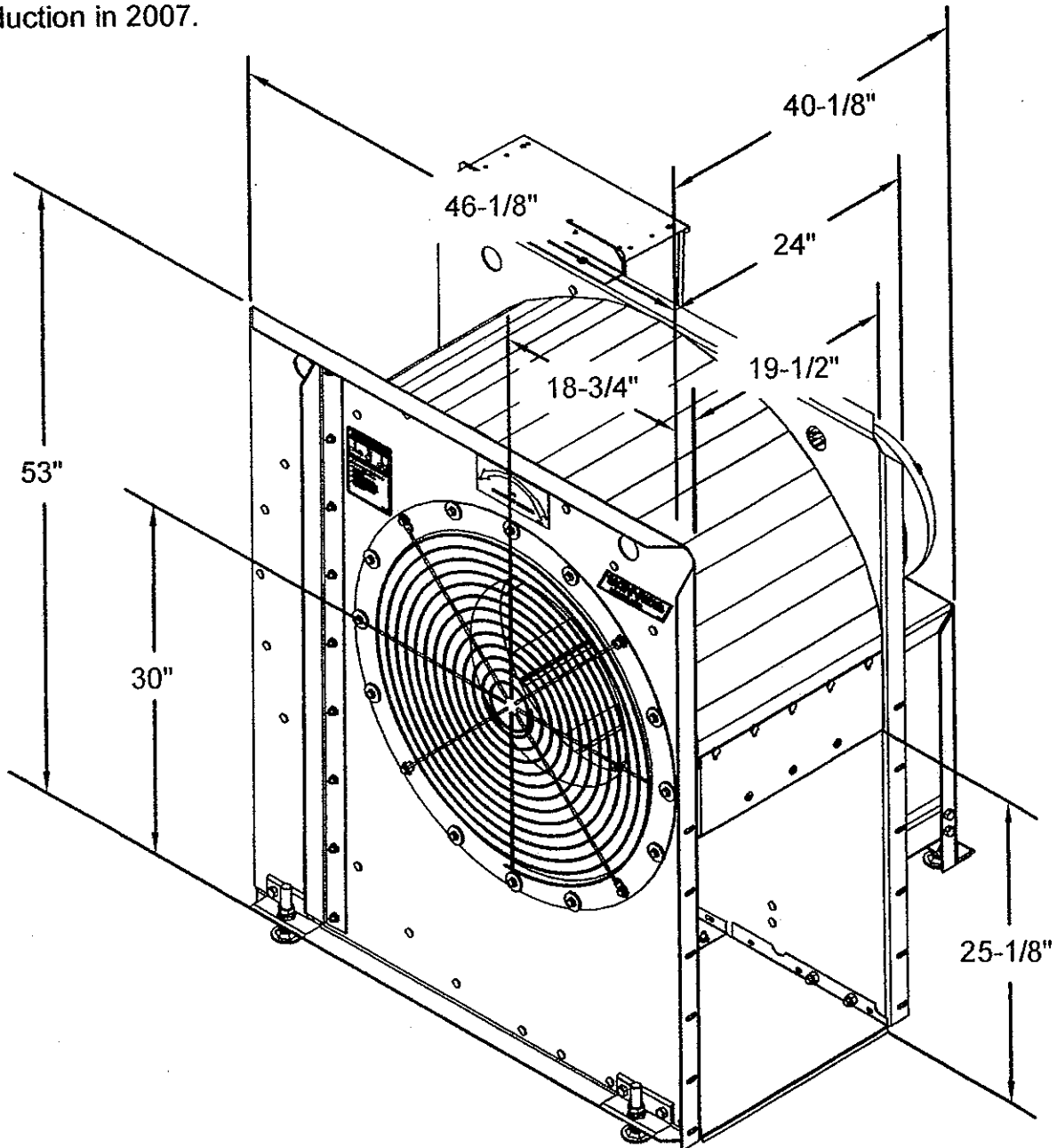

SAFETY INFORMATION

The operator of this equipment must assume responsibility for their own safety and for the safety of those working with them. They must also make sure the equipment was installed properly. Factors that contribute to the overall safety of operation are: proper use, maintenance, and frequent inspection of the equipment. All of these are the operator's responsibility.

If any items covered in this manual are not completely understood, or there is a concern with the safety of the product, contact Shivvers at the address shown on the front cover. Shivvers is genuinely interested in providing the safest practical equipment to our customers. If you have a suggestion which you believe will enhance the safety of the product, please contact us.

Read and understand the Operator's Safety Manual (P-10001), and all applicable operator's manuals, before working on Shivvers equipment.

Read and understand this manual completely before using this equipment.



Take note anytime this safety alert symbol appears. Your safety, and that of persons around you, is at stake.

The safety alert symbol will be accompanied by one of three signal words whose definitions are given as:

DANGER: Red and white. Indicates an imminently hazardous situation that, if not avoided, will result in death or serious injury. This signal word is to be limited to the most extreme situations, typically for machine components that, for functional purposes, cannot be guarded.

WARNING: Orange and black. Indicates a potentially hazardous situation that, if not avoided, could result in death or serious injury, and includes hazards that are exposed when guards are removed. It may also be used to alert against unsafe practices.

CAUTION: Yellow and black. Indicates a potentially hazardous situation that, if not avoided, may result in minor or moderate injury. It may also be used to alert against unsafe practices.

See the Operator's Safety Manual (P-10001) for definitions, proper use of safety locks and disconnects, and for proper bin unloading procedures.

SAFETY INFORMATION

Be sure to observe these common sense rules when working with the dryer equipment:

- 1) All units must be equipped with a main power disconnect switch. This disconnect switch must shut power off to the complete drying system. It must have the capability of being locked into the OFF or OUT position. Disconnect and **LOCK OUT** this main power disconnect switch before conducting any inspection, maintenance, repair, adjustment, or cleaning of the drying system. When you must have the electrical power on to troubleshoot equipment, do it from a safe distance, and always from outside the bin.
- 2) Keep the bin entrances locked at all times. To unlock the bin, first lower the Level-Dry (if so equipped), then shut the main power disconnect off. Take the safety lock off the bin entrance and place it on the main power disconnect before opening the bin entrance. **Never enter the drying bin unless the Level-Dry (if so equipped), is completely lowered, and all power is disconnected and locked out.**
- 3) Always keep all shields and guards in place. If shields or guards must be removed for inspection or maintenance, replace them before unlocking and turning the power back on.
- 4) Be sure everyone is clear of all the drying and transferring equipment, and outside of all bins, before unlocking and turning the power on. Some equipment may run upon re-application of power.
- 5) Make sure that all decals are in place and are easy to read. Do not operate the equipment with missing or illegible decals. If replacements are needed, contact SHIVVERS Manufacturing, Inc. or your dealer.
- 6) Prior to use, inspect all equipment to insure that it is in good operating condition. Do not operate with missing, damaged, or worn parts. Use only SHIVVERS approved replacement parts.
- 7) Metal edges can be sharp. Wear protective clothing and handle equipment and parts with care.
- 8) Keep children and bystanders away from drying and transferring equipment at all times.

SAFETY INFORMATION

- 9) If going up the bin ladder and/or performing maintenance on the top of the bin, take precautions to prevent accidental falls. When on top of the bin, wear a safety harness or other safety device.
- 10) At least annually, review all operating and safety manuals with any personnel working with this equipment. Always train new employees before they operate the drying equipment. Insist that they read and understand the operating and safety manuals.

LOCATION OF SAFETY DECALS

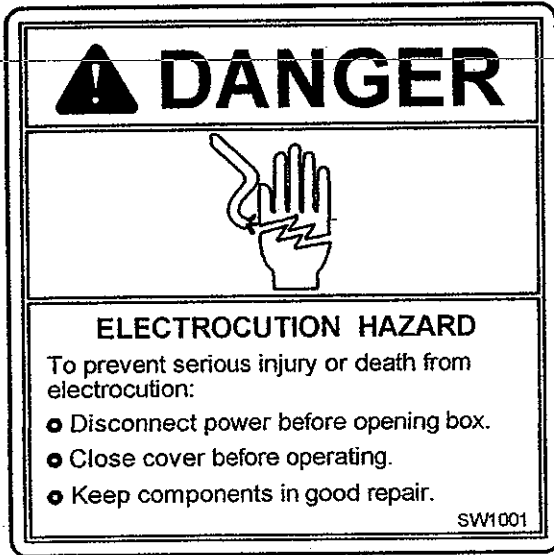

P-11146

Located on outside of Control Box, lower left corner

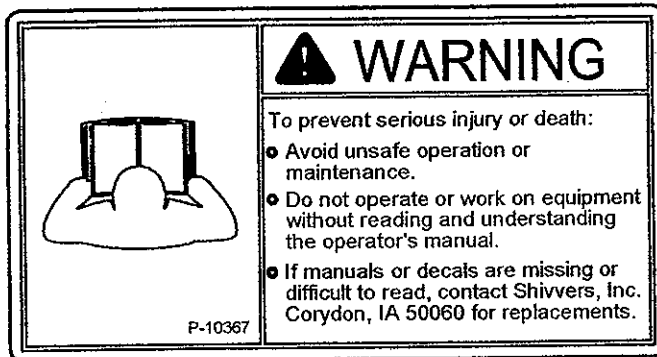
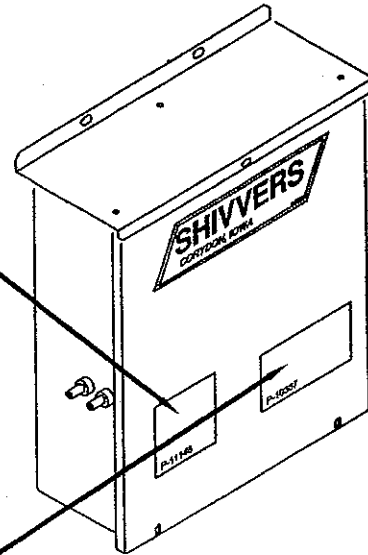

P-10367

Located on outside of Control Box, lower right corner.

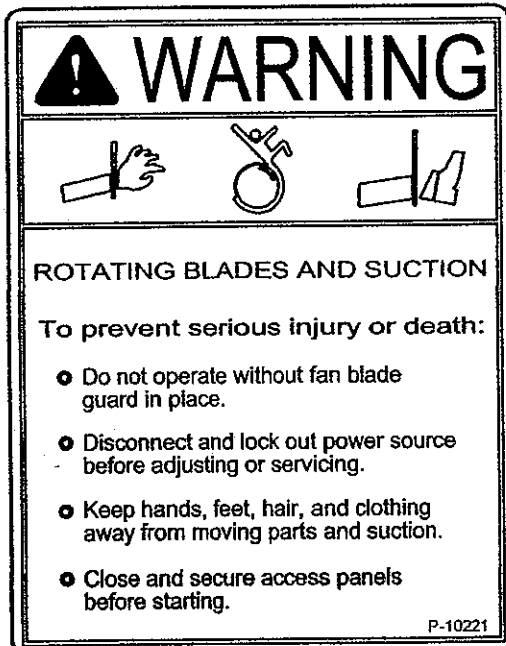

P-10221

Located on Frame Side (Inlet), upper left corner by Grill Guard.

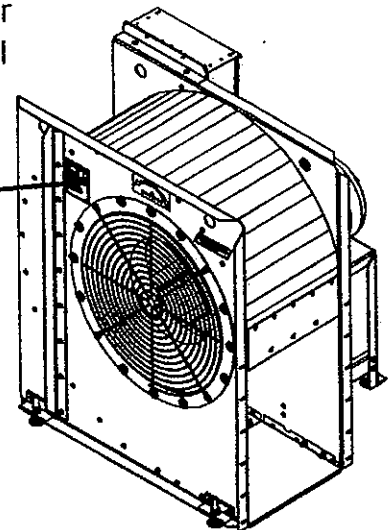

OTHER IMPORTANT DECAL LOCATIONS

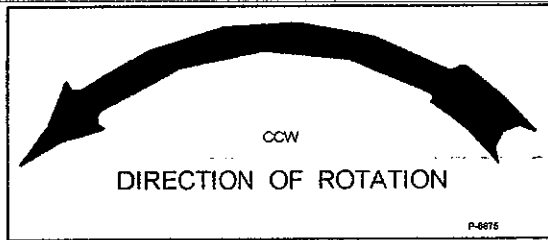

P-8875
 Located on Frame Side (Inlet),
 top center above Grill Guard

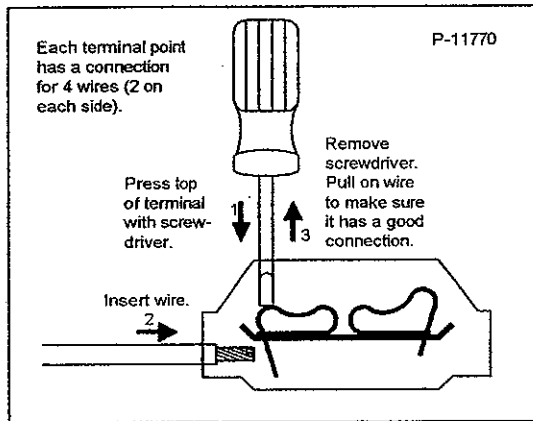
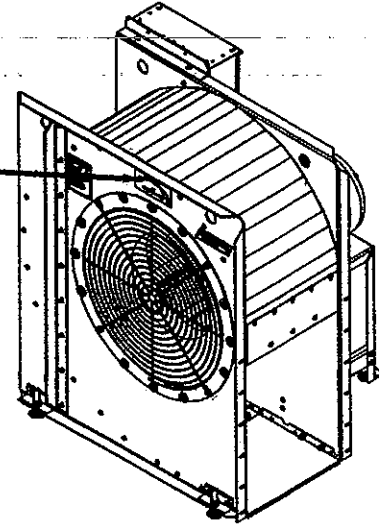

P-11770
 Located on inside of Control Box,
 lower left corner.

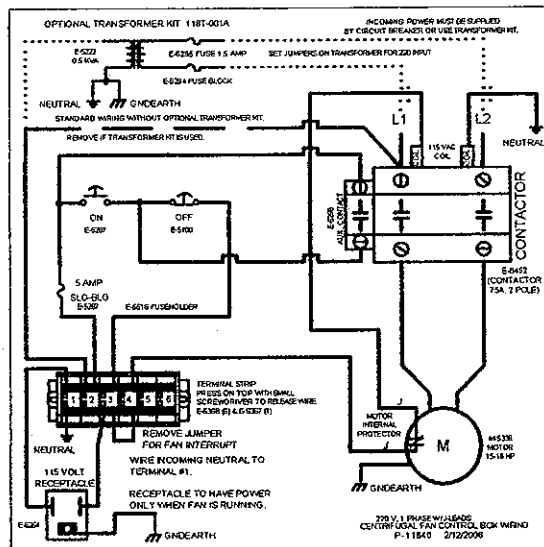
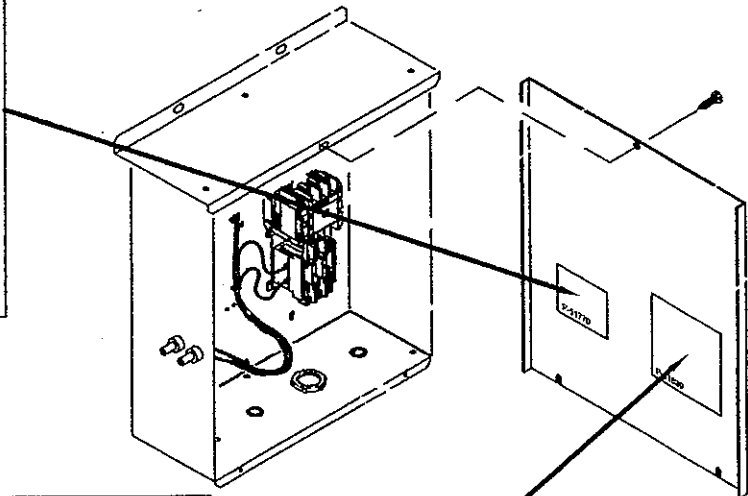

P-11640
 Located on inside of Control Box,
 lower right corner.

IDENTIFICATION OF PARTS

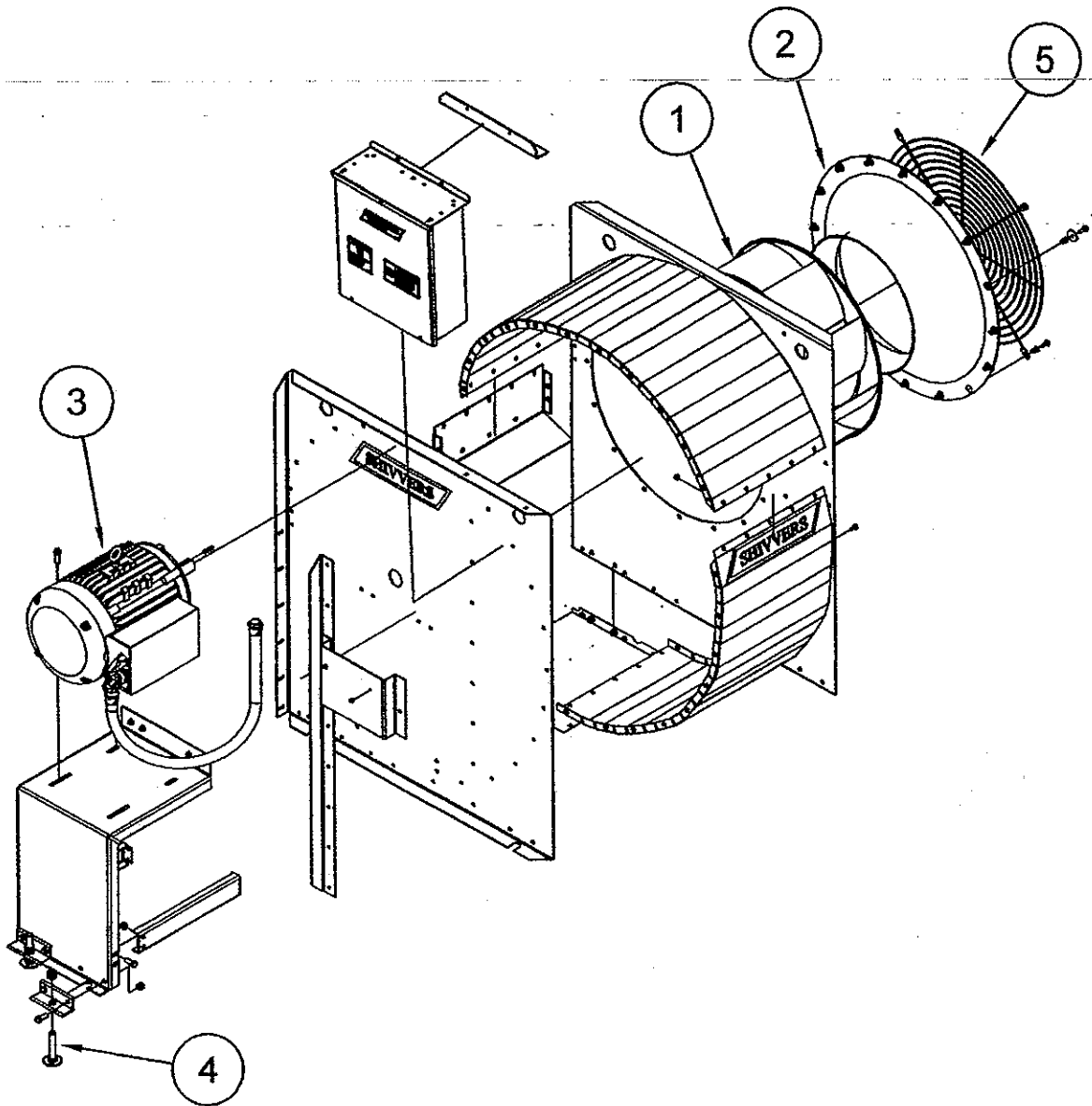

- | | | |
|----|----------|----------------------------------|
| 1. | A-5224 | C-Fan Impeller, 27", 15 Hp |
| 2. | A-5225 | C-Fan Inlet Weldment, 15 Hp |
| 3. | M-5338 | Motor, 16 Hp, Single Phase, 230V |
| 4. | 118-131W | Leveling Leg Weldment |
| 5. | 118-153W | C-Fan Grill Guard, 15 Hp |

IDENTIFICATION OF PARTS

118-181A Control Box, 1 Phase, C-Fan

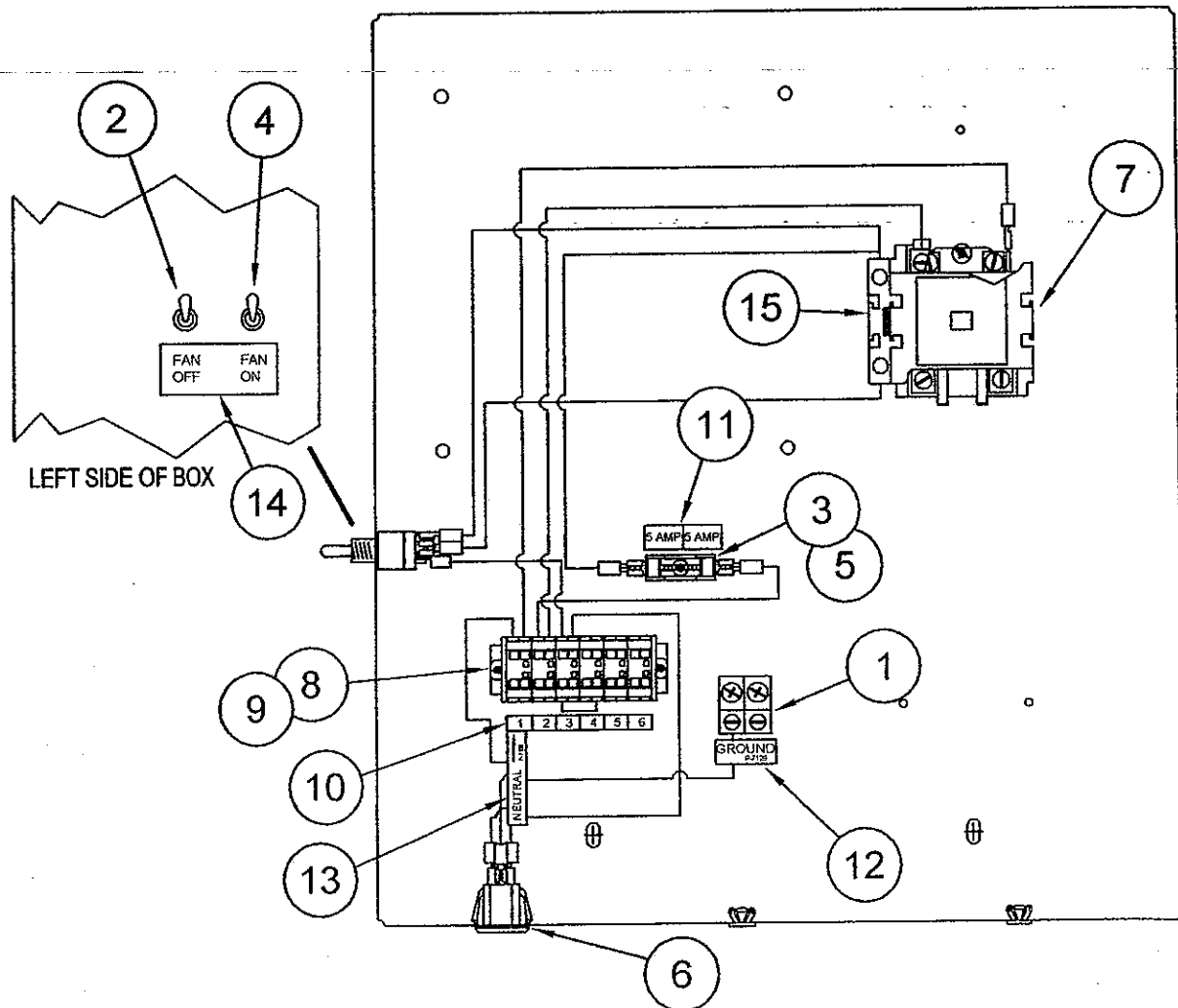

- | | | |
|-----|-----------|--|
| 1. | E-5008-01 | Ground Lug (2) |
| 2. | E-5100 | Switch, MOM, OFF |
| 3. | E-5267 | Fuse, 5 Amp Slo-Blo |
| 4. | E-5287 | Switch, DPST, MOM, ON |
| 5. | E-5616 | Fuseholder |
| 6. | E-6264 | Appliance Inlet |
| 7. | E-6452 | Contactor, 75A, 2 Pole, 120VAC Coil |
| 8. | E-6367 | Terminal End Plate |
| 9. | E-6368 | Terminal, Block Section, 4 Conductor (6) |
| 10. | P-11601 | Decal, 1-12 Terminal Strip |
| 11. | P-7266 | Decal, "5 AMP / 5AMP" |
| 12. | P-7129 | Decal, "Ground" |
| 13. | P-7128 | Decal, "Neutral" Horizontal |
| 14. | P-8381 | Decal, Bumer Fan OFF - Fan ON |
| 15. | E-5296 | Aux. Switch, Long Arm, GE |

MECHANICAL INSTALLATION

DRYING BIN LAYOUT

- A) ~~The horizontal unloader must come out of the bin near the main entrance door.~~
- B) The Compudry Command Center, (or installed controller), must be within line of sight of the bin's main entrance door. The plenum temperature sensing device of the Compudry Command Center (or installed controller) must be at least 12 feet from the nearest burner.
- C) There must be a main electrical disconnect switch. This switch must shut off all electrical power to the drying system. It must have the capability of being locked in the OFF position. It must be located near the bin's main entrance and within line of sight of the Compudry Command Center, (or installed controller).
- D) The Centrifugal Fans should be located as shown in the following drawings whenever possible. They must be installed as shown for certified performance systems.
- E) A lockable disconnect switch for the Machine (Circu-Lator or Dri-Flo) Motor is required near the bin entrance. This disconnect switch is NOT supplied by Shivers, but can be obtained locally.
- F) It is recommended to use only Shivers entrance collars, transitions, and burners. Follow instructions provided with transitions for their installation. For drying bins with more than one burner, air dampers are required to prevent reverse airflow.
- G) Keep the floor space in front of the entrance collar as free of obstructions as possible. Concrete blocks are not recommended for floor supports. They block too much airflow. Floor supports should be at least 15" tall. Shorter supports do not allow even heat under the floor.
- H) Concrete pads for Shivers Centrifugal Fans, transitions, and burners should be 12 feet long by 5 feet wide. This size pad should accommodate fans up to 20 Hp. The pad may be made smaller if you carefully measure your transition, burner and fan, and offset the pad to the motor side of the fan. Pads should be flush and level with the top of the bin concrete. Place footers under the pads and use re-rod to keep the pads from cracking and moving.

MECHANICAL INSTALLATION

Shivvers Circulator 1-Fan Layout

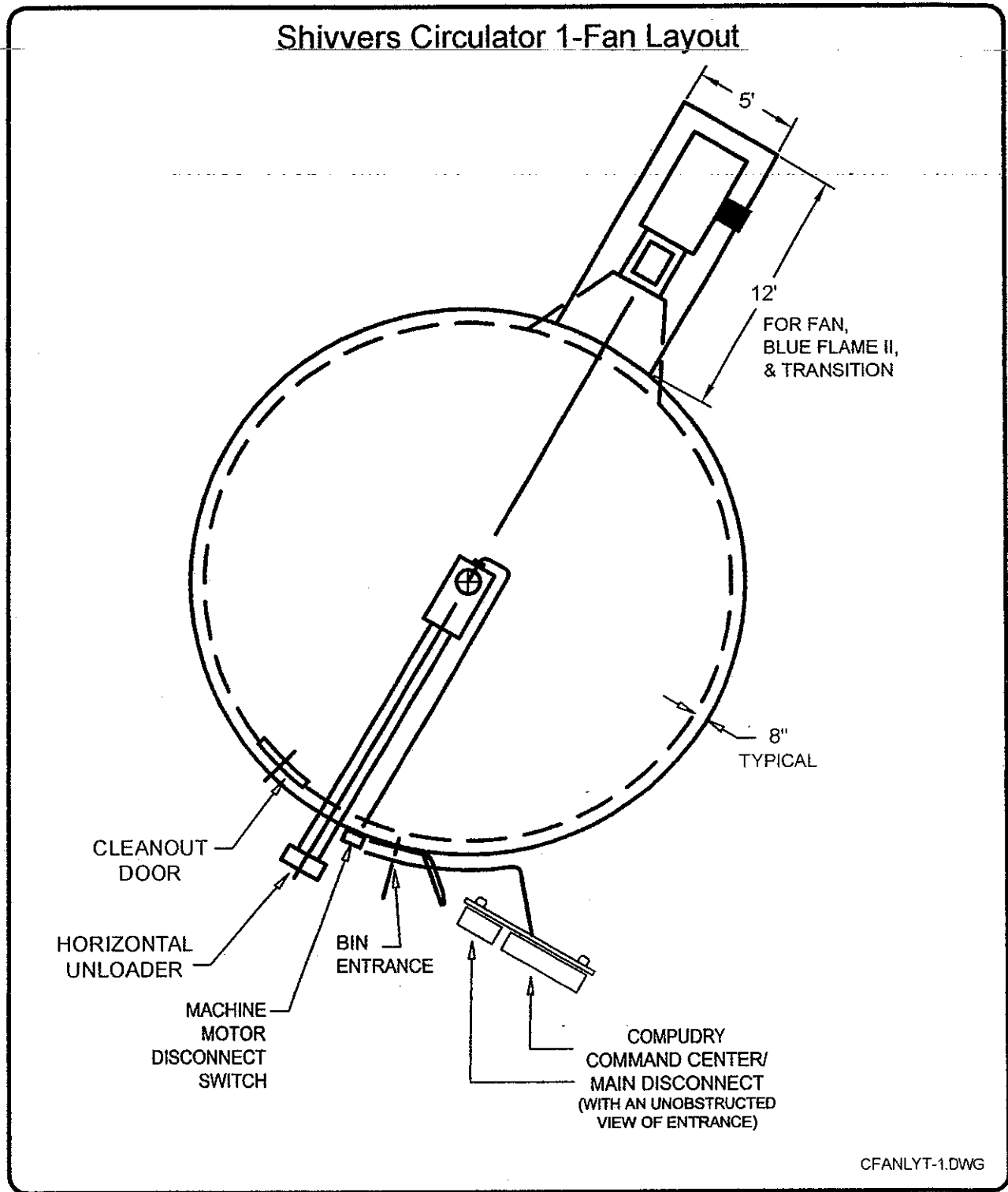

MECHANICAL INSTALLATION

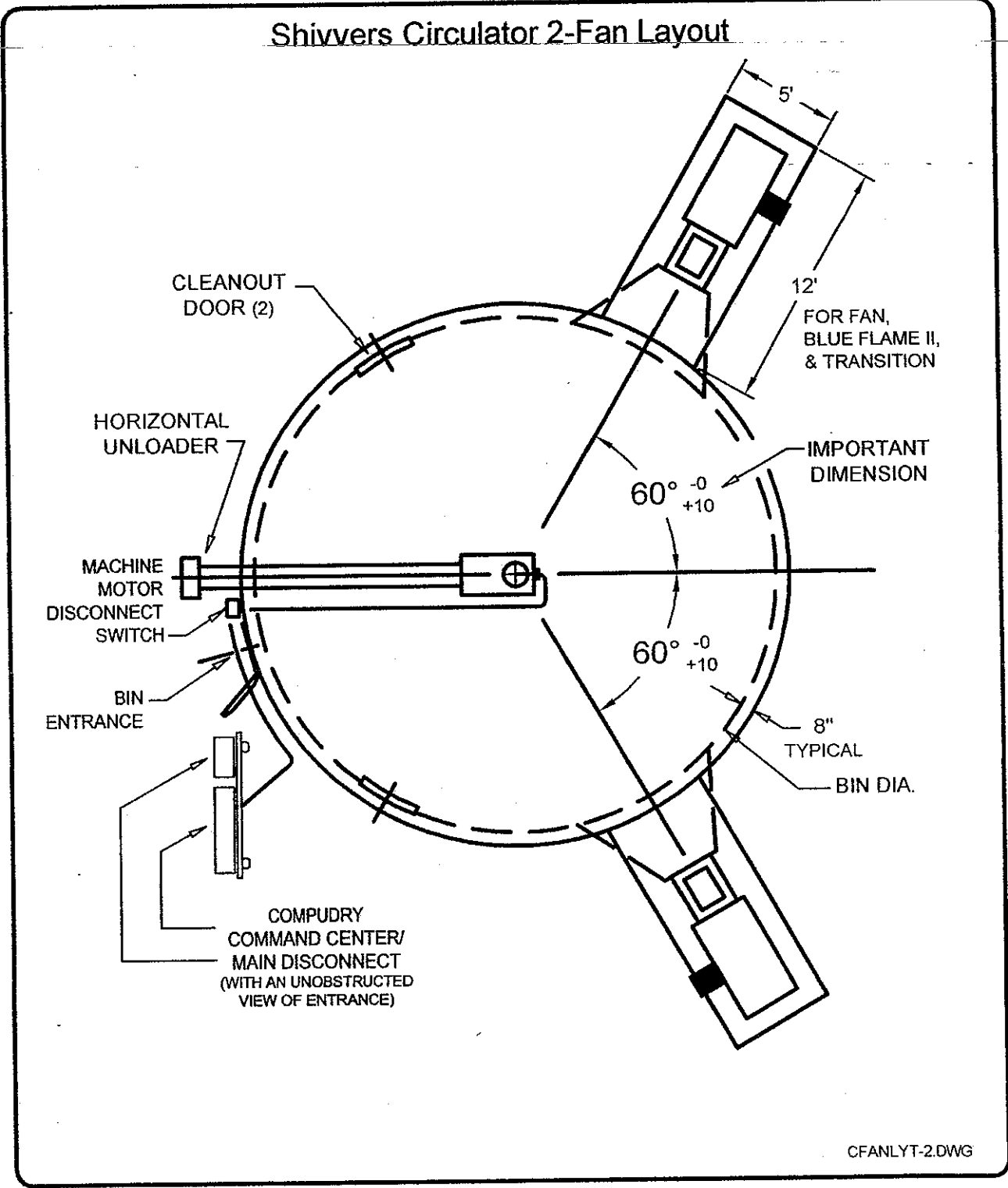

MECHANICAL INSTALLATION

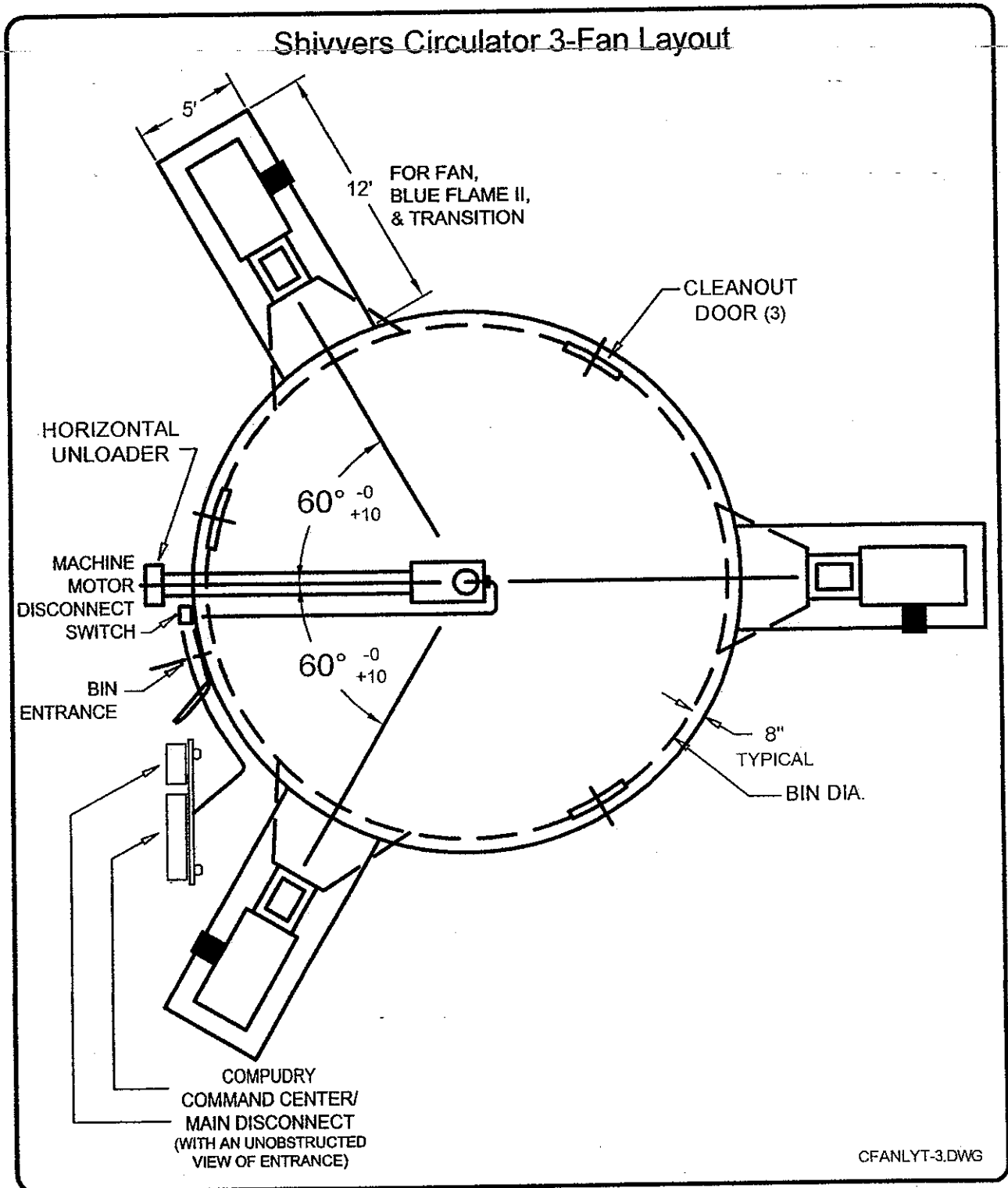

MECHANICAL INSTALLATION

C-FAN

- 1) ~~Install entrance collar, transition, and burner according to instructions supplied with each of them.~~
- 2) Put fan up to burner. Adjust leveling legs for a good fit to burner.
- 3) Bolt fan to burner using hardware from 118-121A Hardware Sack, located in the Control Box. Caulk any air gaps.
- 4) Lock leveling legs in place.

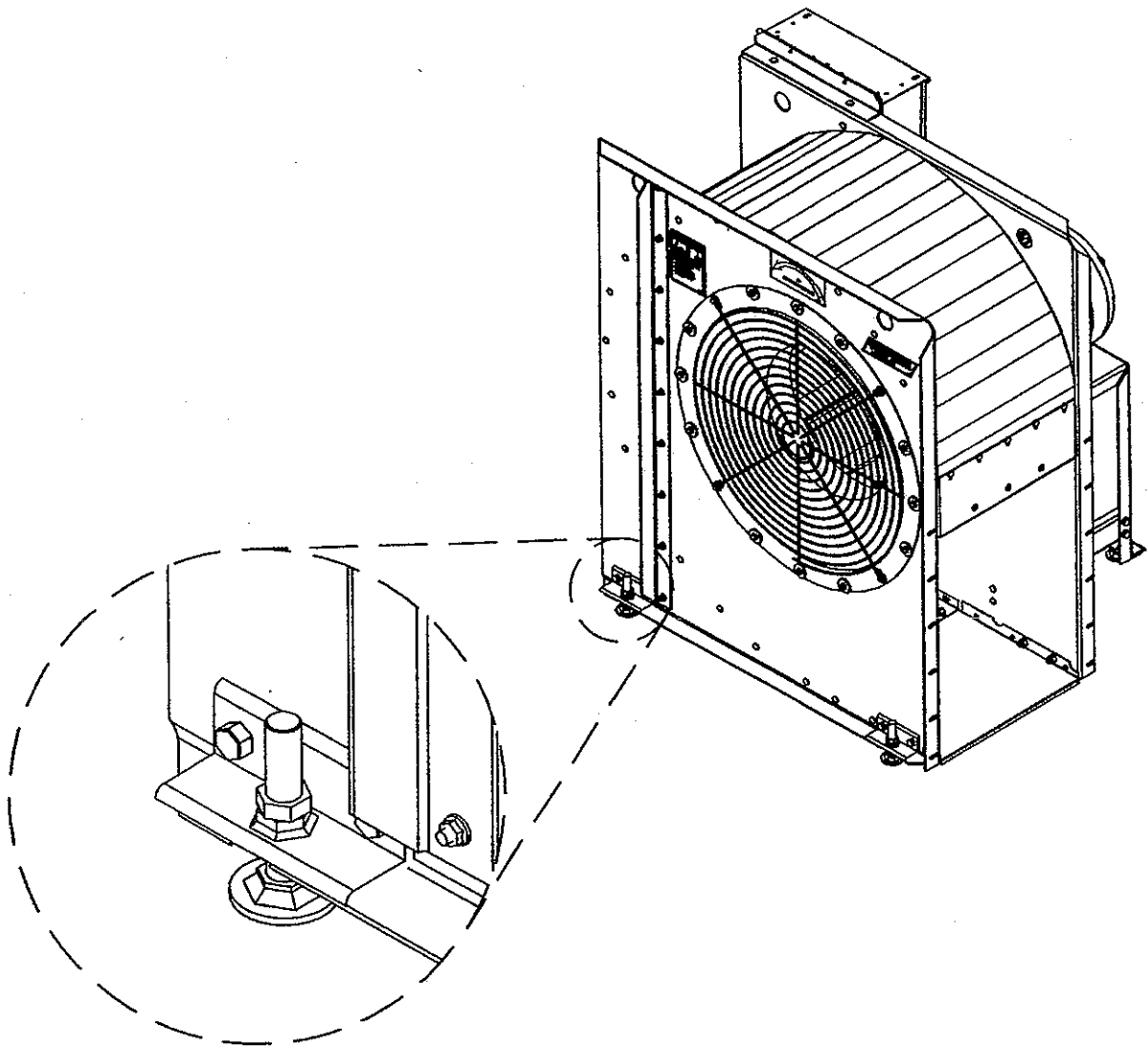

ELECTRICAL INSTALLATION

ALL ELECTRICAL WIRING SHALL BE INSTALLED IN COMPLIANCE WITH THE LATEST EDITION OF THE ANSI/NFPA STANDARD 70, NATIONAL ELECTRICAL CODE, AS A MINIMUM REQUIREMENT, AND IN COMPLIANCE WITH LOCAL WIRING CODES AS APPLICABLE.

WIRING MUST BE DONE BY A COMPETENT ELECTRICIAN. A LICENSED ELECTRICIAN IS RECOMMENDED, AND MUST BE USED WHEN REQUIRED BY LOCAL OR STATE STATUTES.



Disconnect and lock out all power before wiring.

INCOMING POWER HOOKUP

- 1) The 15 Hp Centrifugal fan is built for 220 Volt single phase input. It uses 115 Volt control voltage. If fuses are used instead of circuit breakers on incoming power, a 0.5 kVA control voltage transformer (available from Shivers, Part # 118T-001A) must be installed for the control voltage. Contact the factory if more information is required.)
- 2) A circuit breaker must be installed in line with the incoming power to the C-Fan control box. The circuit breaker should break both lines if an overload occurs on any single line. An inverse time delay circuit breaker is recommended to handle the motor inrush current while starting the fan. The breaker can be up to 2.5 times the motor nameplate full load amps. Aluminum wire is not recommended, but if used, the wire size must be increased. If the distance from the power company transformer, or the C-Fan circuit breaker, is greater than 100 feet, it may be necessary to increase the wire sizes.
- 3) An access hole is provided in the control box for the incoming wiring conduit. If the conduit is attached to the bin wall, keep it at least 3 feet above the foundation to keep the ambient temperature lower. If the bin side wall will be covered with insulating foam, make sure the electrical conduit is not under the foam. When running the conduit from the bin wall to the C-Fan, make sure it does not interfere with air damper operation. Make sure it does not block access through the transition lid. Make sure it does not touch the entrance collar or transition as these can get hot.

ELECTRICAL INSTALLATION

It is recommended to use a flexible conduit to the C-Fan. Leave enough flex in the conduit so the Fan can be removed to allow servicing of the burner.

15 Hp C-FAN INCOMING POWER WIRING

<u>VOLTAGE</u>	<u>PHASE</u>	<u>MAX FULL LOAD AMPS</u>	<u>MIN. BREAKER SIZE</u>	<u>MIN. COPPER WIRE SIZE</u>	<u>MIN. CONDUIT SIZE</u>
220V	1	62	100	4 AWG	1-1/4 INCH

- 4) It is necessary to have an incoming ground wire (marked green) with the incoming power leads. It should not be more than 1 size smaller than the incoming power leads. It should be connected to earth ground at the breaker panel and at the grounding terminal in the C-Fan control box.
- 5) It is necessary to have an incoming neutral (white) wire with the incoming power leads for the 115 Volt control circuits (unless a control transformer is used). The neutral connection is made to terminal 1. This should be at least a 14 gauge wire.
- 6) The incoming power leads are connected to the top of the motor starter in the C-Fan control box.
- 7) The C-Fan control power is connected at the factory to one lead of the motor starter. If a control voltage transformer is used, the control power wire is removed from the starter and placed on the transformer secondary. Make sure the control circuitry is not exposed to more than 125 Volts maximum! If the control voltage transformer is used, the other secondary terminal will go to both ground and neutral for proper burner operation.

ELECTRICAL INSTALLATION

The C-Fan 6 pole terminal strip is a spring cage clamp type. The following diagram shows how to properly connect the wires. Make sure the wire is lined up to go straight into the terminal before pressing on the spring.

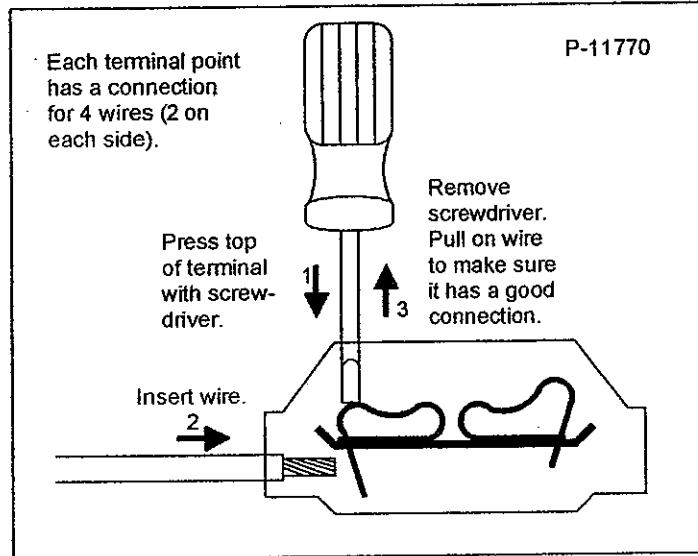

An outlet is provided in the bottom of the C-Fan Control Box for supplying 115VAC to a Shivers Blue Flame II Burner. It will only have power when the C-Fan is running.

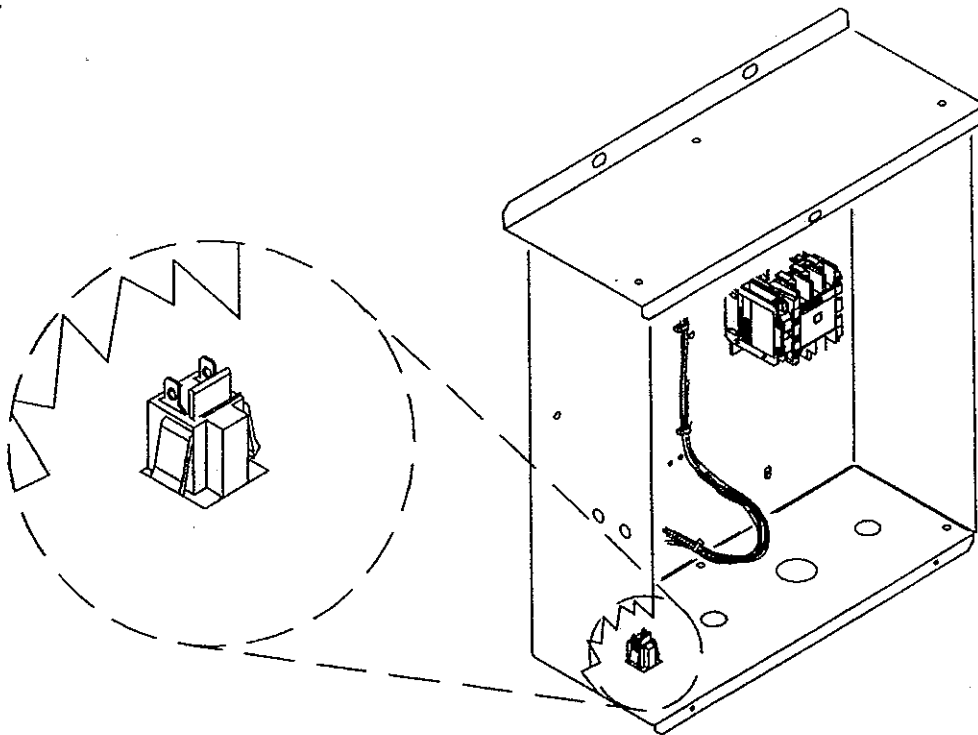

INITIAL CHECKOUT

- 1) Once the wiring is completed, make sure the burner is unplugged from the C-Fan. Make sure everyone is out of the grain bin and are safely away from all drying equipment, then unlock the main power. Lock the bin entrances shut, then turn on the main power.
- 2) Measure the control voltage from Neutral (Terminal #1) to the 5 Amp fuse. It should be between 110 and 125 volts AC. If it is not, disconnect and lock out the power, and recheck the wiring.
- 3) Press the fan start switch. The fan should start.
- 4) Press the fan off switch. The fan should slow down and stop.
- 5) Check for proper rotation of the fan. Looking into the fan venturi, rotation should be counter-clockwise. Air should be blowing into the bin.
- 6) Plug the burner into the outlet on the bottom of the C-Fan Control Box. Re-start the fan and test the burner, following instructions provided with it.
- 7) Disconnect and lock out the main power.

OPERATION

TO OPERATE

- 1) Make sure the fan blade is not turning backwards.
- 2) Press the Fan ON momentary switch.
- 3) The fan should start and come up to full speed. The burner will now have power.

TO STOP

- 1) Turn off the burner, or turn off the gas and allow the gas in the lines to burn out. (See burner manual for more instructions.)
- 2) Press the Fan OFF momentary switch. The fan should coast down and stop.

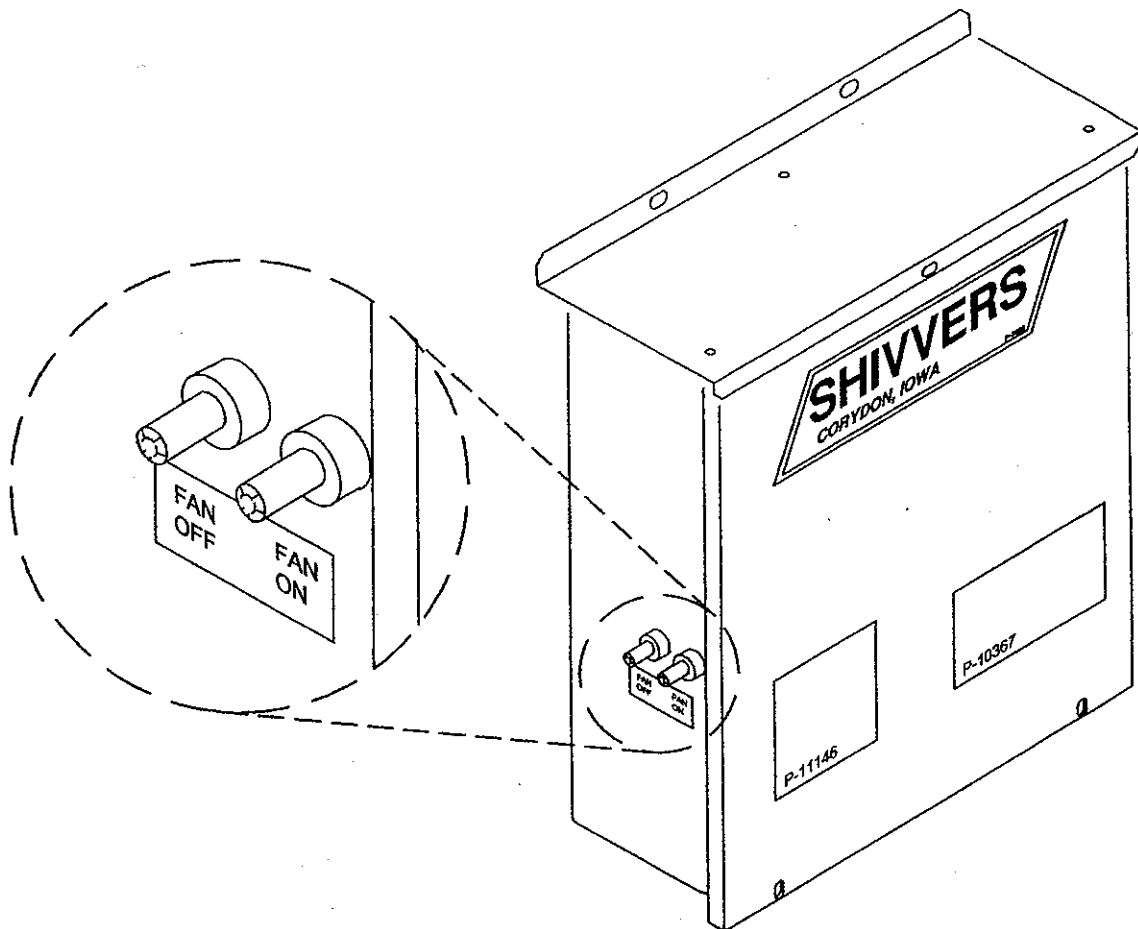

MAINTENANCE

! DANGER

Disconnect and lock out all power before opening any control boxes or removing any shields. Make sure everyone is clear of all drying equipment before restoring power.

- 1) Once every month, start the fan to circulate the grease in the motor bearings. In the off season, do not allow the fan blades on single phase units to free wheel with the wind. It can wear a groove in the centrifugal start switch. Follow motor manufacturer's recommendations for re-lubricating motor bearings.
- 2) Prior to each drying season, make sure the fan blade rotates freely. Make sure the blade is not coated by any foreign material which could unbalance it or block airflow. If blade requires cleaning, make sure power is disconnected and locked out first!
- 3) Prior to each drying season, check to be sure all wiring connections are tight and that the insulation is good. Make sure there isn't any foreign material inside the magnetic motor starter.
- 4) Maintain a clean operation. Clean up spilled corn, clean out fines under the bin floor (contact Shivers about clean-out doors), keep all control boxes shut and replace seals if required. Control the rodent population. Control weeds and tall grasses around the C-Fan. They can get sucked in and block airflow or start a fire. They can interfere with damper operation.
- 5) During the drying season, check the transition dampers for free movement and proper operation.
- 6) At the end of the season, make sure the main power is disconnected and locked off. There will be fewer problems with lightning damage with all switches and breakers open.

TROUBLESHOOTING



Disconnect and lock out all power before opening any control boxes or removing any shields. Make sure everyone is clear of all drying equipment before restoring power.

Only qualified personnel should perform troubleshooting on energized circuits.

All terminal strip numbers refer to the 6 pole terminal strip in the C-Fan control box unless otherwise noted.

C-FAN WILL NOT START

- 1) Make sure the circuit breaker for the C-Fan is turned on.
- 2) Check 5 amp slow blow fuse.
- 3) Check for power on terminal #3 with the fan start switch held down. If no power, it could be a bad start switch or stop switch.
- 4) Check for power on terminal #4 with the fan start switch held down. If there is no power, there is a problem with the fan interrupt. This could be a Gearbox or Grain Hi-Limit problem. If connected to a Compudry Command Center, make sure the Fan(s) Enabled light is on and the fan fuse in the Command Center is good.
- 5) Check for power on the blue coil wire on the contactor with the fan start switch held down. If there is no power, there is a problem with the Motor Thermal Switch (J-Leads). Jumper around the J-leads and try again. If the motor runs OK, add an overload switch and heater strip to the control box to take place of the J-leads.
- 6) If there is power on terminal #1 when the fan start switch is held down, there is an open neutral. Make sure terminal #1 is connected to a neutral.
- 7) If there is power at the blue wire on the fan motor starter coil, and not at the white neutral wire on the starter coil, when holding down the fan start switch, then the starter coil is open and will need to be replaced.

TROUBLESHOOTING

FAN WILL RUN ONLY WHILE START SWITCH IS HELD DOWN
(stops when start switch is released)

- 1) Defective (open) auxiliary switch on starter.

FAN WILL STOP ONLY WHILE STOP SWITCH IS HELD DOWN
(starts back up when stop switch is released)
(starts when circuit breaker is turned on)

- 1) Defective (shorted) auxiliary switch on starter.
- 2) Defective (shorted) fan start switch.

SCHEMATIC

