



**SHIVVERS**

**CORYDON, IOWA**

**GEARBOX AND BASKET PARTS MANUAL**



**6" & 8" CIRCULATOR I  
GEARBOX AND BASKET**

ITEM	DESCRIPTION	QTY	PART NO.
1	Spider Wheel Assembly (423-068-001A)	1	222-036A
2	Gearbox Assembly, W/Base+Flange	1	203E-001A
3	Basket End Plate, #781	2	102-007P
4	Basket Assembly	1	227G-001A
5	Slide Gate Weldment	1	125-052W
6	Bottom Front Plate Weldment, 6"	1	222Z-082W
6	Bottom Front Plate Weldment, 8"	1	226D-015W

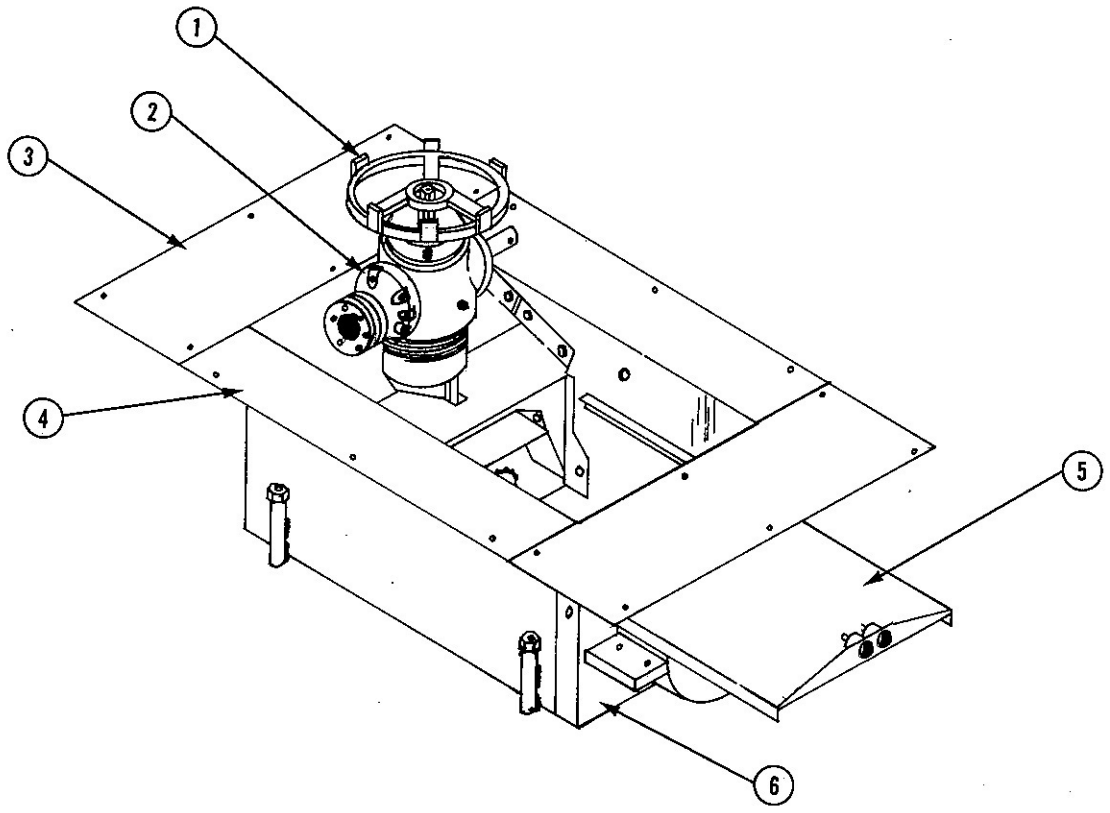

**6" & 8" CIRCULATOR I  
BASKET INSTALLATION HARDWARE**

ITEM	DESCRIPTION	QTY	PART NO.
1	Basket Assembly	1	95A-001A
2	Basket End Plate, #781	2	102-007P
3	Slide Gate Weldment	1	125-052W
4	Half Band, 6"	1	201Z-023P
4	Half Band, 8"	1	201B-024P
5	6" Bottom Front Plate Weldment	1	222Z-082W
5	8" Bottom Front Plate Weldment	1	226D-015W
6	Spider Wheel Assembly (423-068-001A)	1	222-036A
7	Leg, Basket Weldment	4	222-037W
8	Sack, Chain Coupler	1	222-029A
A	Basket Sack	1	222-085A
9	Nut, Hx Znc Pltd, 3/4"-10 Unc-2B	4	F-1011-07
10	Nut, Hx Znc Pltd, 3/8"-16, Stover	4	F-1005-03
11	Capscrew, Hx, 3/8"-16 x 3/4", Gr. 2	4	F-1006-23
12	Blind Rivet, 3/16D, .501-.625	16	F-1095
13	Capscrew, Button 3/8"-16 x 1/2"	6	F-1210
14	Washer, Flat, Std, Steel, 3/8"	12	F-1009-03
15	Capscrew, Hx, 3/8"-16 x 1-3/4", Gr. 2	4	F-1006-28
16	Gearbox Assembly	1	203E-001A

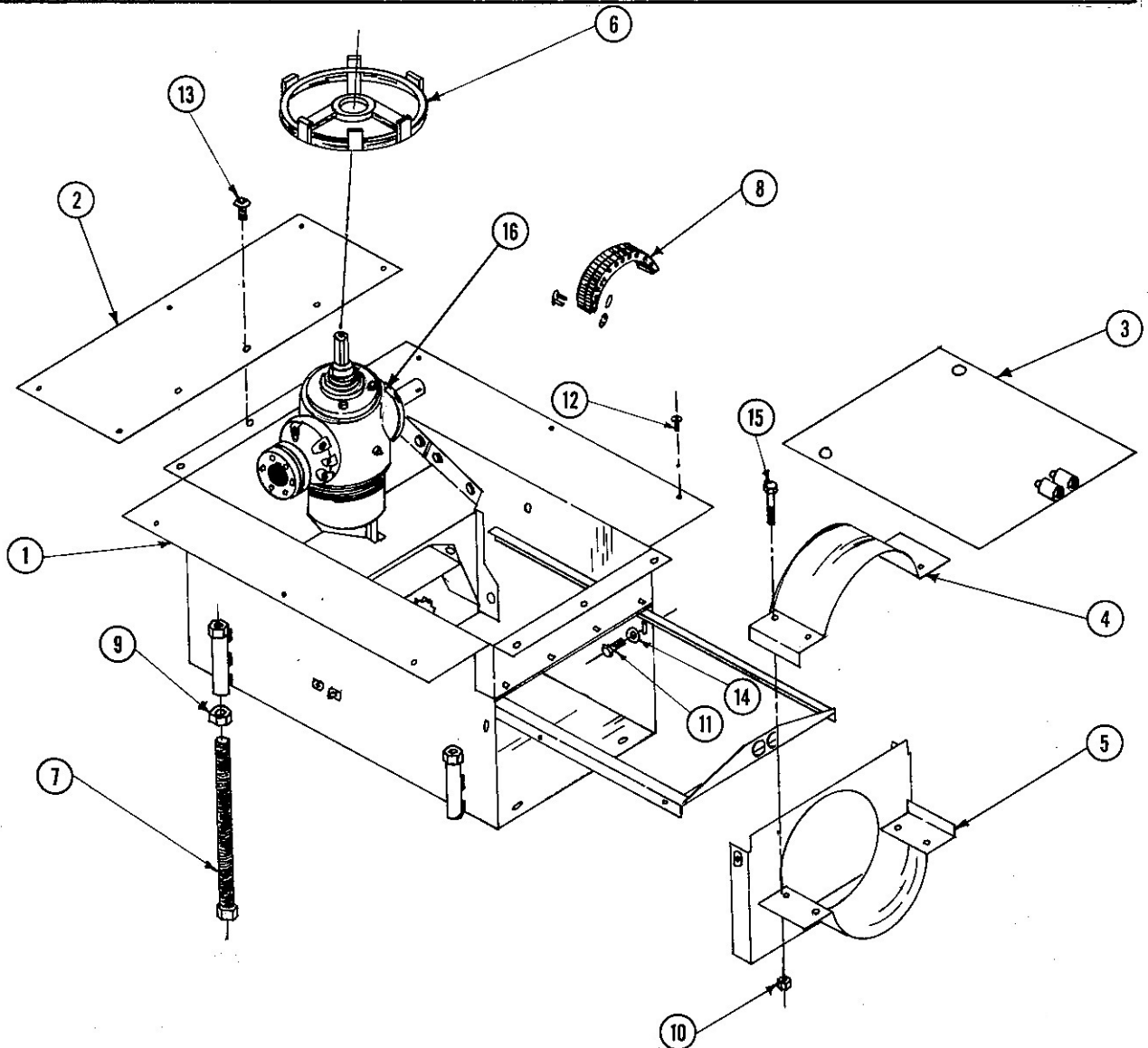

**CIRCULATOR II  
GEARBOX AND BASKET**

ITEM	DESCRIPTION	QTY	PART NO.
1	H.D. Spider Wheel Assembly (423-069-001A)	1	223-003A
2	Gearbox Assembly, Twin Sweep W/Base+Flange	1	428E-001A
3	Basket End Plate #781	2	102-007P
4	Basket Assembly	1	125I-001A
5	Slide Gate Weldment	1	125-052W
6	Bottom Front Plate Weldment	1	226D-015W

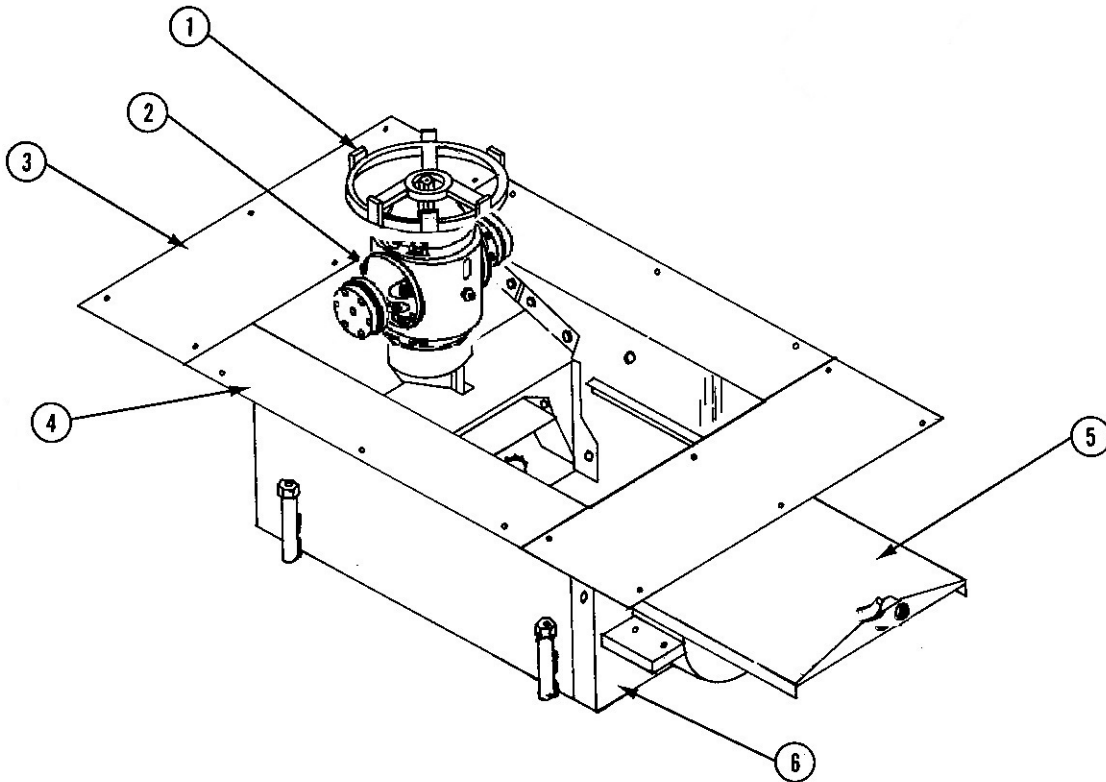

**CIRCULATOR II  
BASKET INSTALLATION HARDWARE**

ITEM	DESCRIPTION	QTY	PART NO.
1	Basket Assembly	1	125I-001A
2	Basket End Plate #781	2	102-007P
3	Slide Gate Weldment	1	125-052W
4	Half Band, 8"	1	201B-024P
5	Bottom Front Plate Weldment	1	226D-015W
6	H.D. Spider Wheel Assembly (423-069-001A)	1	223-003A
7	Leg, Basket Weldment	4	222-037W
8	Sack, Chain Coupler	1	222-029A
A	Basket Sack, 781 Basket	1	222-085A
9	Nut, Hx Znc Pltd, 3/4"-10 Unc-2B	4	F-1011-07
10	Nut, Hx Znc Pltd, 3/8"-16, Stover	4	F-1005-03
11	Capscrew, Hx, 3/8"-16 x 3/4", Gr. 2	4	F-1006-23
12	Blind Rivet, 3/16D, .501-.625	16	F-1095
13	Capscrew, Button 3/8"-16 x 1/2"	6	F-1210
14	Washer, Flat, Std Stee, 3/8"	12	F-1009-03
15	Capscrew, Hx, 3/8"-16 x 1-3/4", Gr. 2	4	F-1006-28
16	Gearbox Assembly, Twin Sweep W/Base+Flange	1	428E-001A

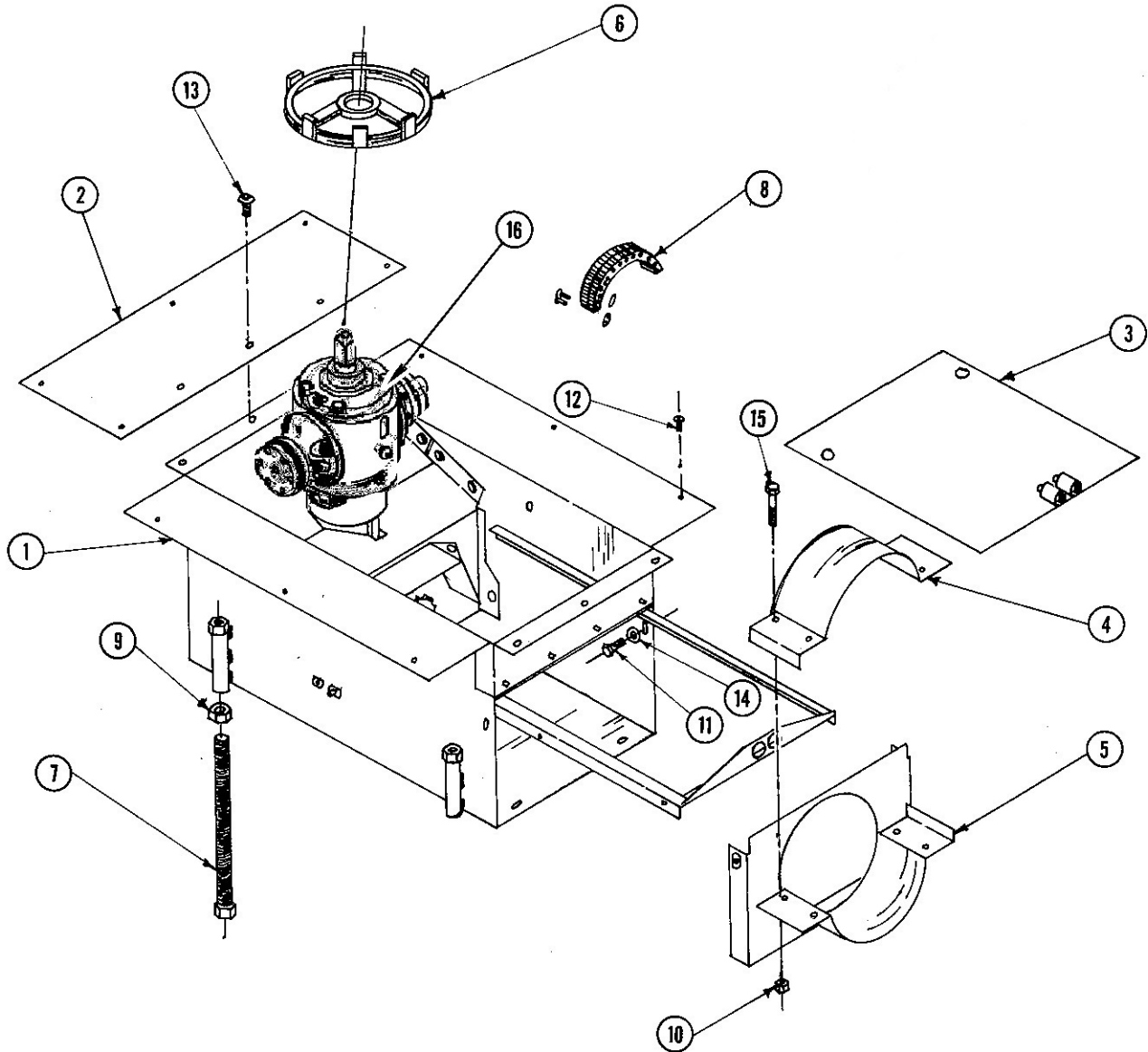

BASKET ASSEMBLY, CIRCULATOR I  
HIGH PLENUM FLOOR  
(95A-001A)

CORYDON, IOWA

ITEM	DESCRIPTION	QTY	PART NO.
1	Body Weldment	1	95-002W
2	Attaching Strip, Grain Stop	1	95-030P
3	Front Plate, Grain Stop	1	95-029P
4	Chain Coupler Shield	1	95-020P
5	Lower Slope Plate Weldment, 2" Slot	1	95-012W
6	Gearbox Mount Weldment	1	95-013W
7	Gearbox, Hi Limit Assembly	1	95-035A
8	Sprocket, 12 Tooth, Hole At 3/4"	1	220-021P
9	Roll Pin Double, H.D. 5/16" x 1-3/4"	1	F-1036-37
10	Key, Wdrf. Usas 806 #91 1/4" x 3/4"	1	D-1004-02
11	Gearbox 8" W/Base+Flange	1	203E-001A
12	Grease Fitting	1	H-1010-04
13	Upper Slope Plate CL, Notched Flange	1	95-019P

BASKET ASSEMBLY, CIRCULATOR II  
HIGH PLENUM FLOOR  
(125I-001A)

ITEM	DESCRIPTION	QTY	PART NO.
1	Body Weldment, Basket	1	95-002W
2	Attaching Strip, Grain Stop	1	95-030P
3	Front Plate, Grain Stop	1	95-029P
4	Chain Coupler Shield	1	95-020P
5	Lower Slope Plate Weldment, 2-1/2" Slot	1	125-004W
6	Gearbox Mount Weldment	1	125-002W
7	Gearbox, Hi Limit Assembly	1	95-035A
8	Sprocket, 12 Tooth, Hole At 3/4"	1	220-021P
9	Roll Pin, Double, HD, 5/16" x 1-3/4"	1	F-1036-37
10	Key, Wdrf. Usas 806, #91 1/4" x 3/4"	1	D-1004-02
11	Gearbox, Twin Sweep, W/Base+Flange	1	428E-001A
12	Grease Fitting	1	H-1010-04
13	Upper Slope Plate, CL II	1	125-006P



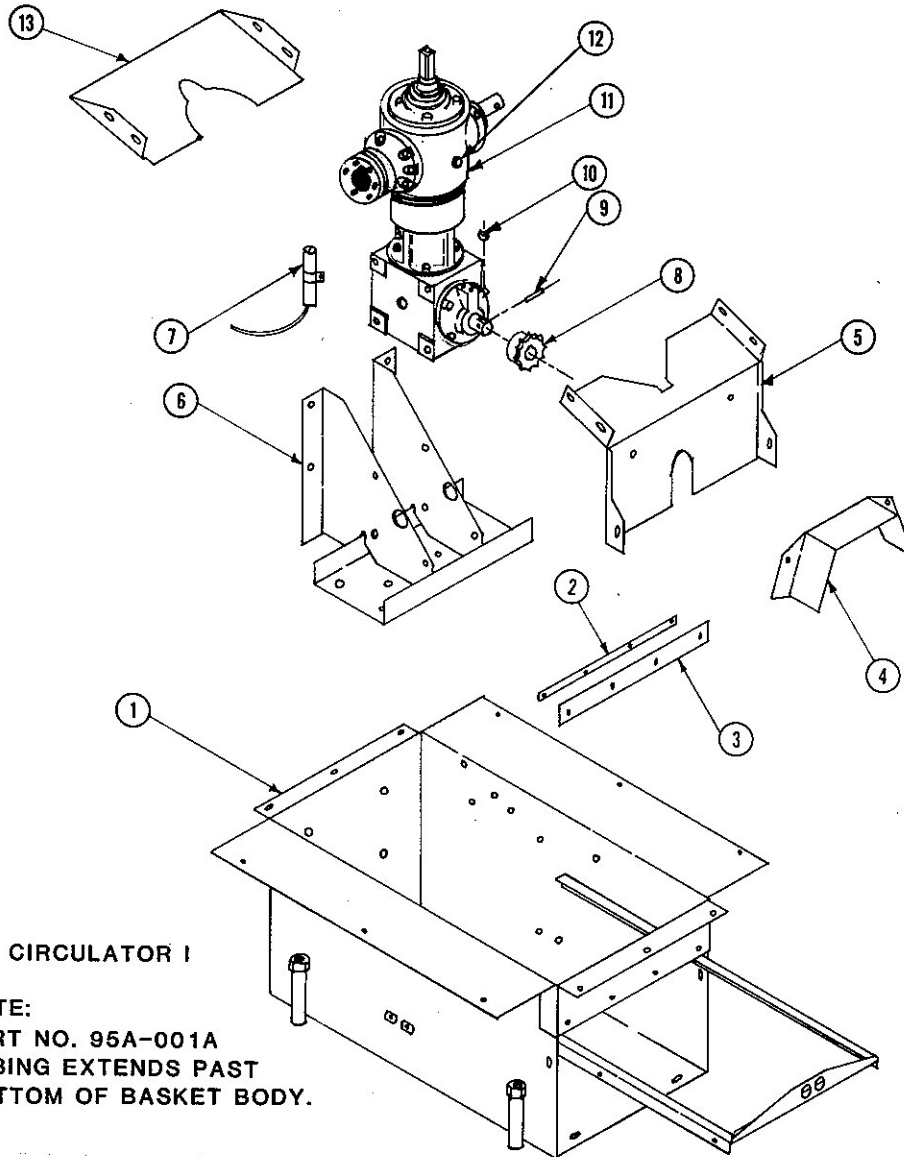

CIRCULATOR I

NOTE:  
PART NO. 95A-001A  
TUBING EXTENDS PAST  
BOTTOM OF BASKET BODY.

CIRCULATOR II

NOTE:  
PART NO. 125I-001A  
TUBING EX ENDS PAST  
BOTTOM OF BASKET BODY.



**BASKET ASSEMBLY, CIRCULATOR I  
LOW PLENUM FLOOR  
(140A-001A)**

CORYDON, IOWA

ITEM	DESCRIPTION	QTY	PART NO.
1	Body Weldment, Basket	1	140-002W
2	Attaching Strip, Grain Stop	1	95-030P
3	Front Plate, Grain Stop	1	95-029P
4	Chain Coupler Shield	1	95-020P
5	Lower <span style="float: right;">ot</span>	1	95-012W
6	Gearb <b>OBSOLETE</b>	1	95-013W
7	Gearb	1	95-035A
8	Sprocket, 12 Tooth, Note No. 5/7	1	220-021P
9	Roll Pin, Double, HD, 5/16" x 1-3/4"	1	F-1036-37
10	Key, Wdrf. Usas 806, #91 1/4" x 3/4"	1	D-1004-02
11	Gearbox 8" W/Base+Flange	1	203D-001A
12	Grease Fitting	1	H-1010-04
13	Upper Slope Plate	1	95-019P

**BASKET ASSEMBLY, CIRCULATOR II  
LOW PLENUM FLOOR  
(140C-001A)**

ITEM	DESCRIPTION	QTY	PART NO.
1	Body Weldment, Basket	1	140-006W
2	Attaching Strip, Grain Stop	1	95-030P
3	Front Plate, Grain Stop	1	95-029P
4	Chain Coupler Shield	1	95-020P
5	Lower <span style="float: right;">Slot</span>	1	125-004W
6	Gearb <b>OBSOLETE</b>	1	125-002W
7	Gearb	1	95-035A
8	Sprocket, 12 Tooth, Note No. 5/7	1	220-021P
9	Roll Pin, Double, HD, 5/16" x 1-3/4"	1	F-1036-37
10	Key, Wdrf. Usas 806, #91 1/4" x 3/4"	1	D-1004-02
11	Gearbox, Twin Sweep, W/Base+Flange	1	428B-001A
12	Grease Fitting	1	H-1010-04
13	Upper Slope Plate, Circulator II	1	125-006P

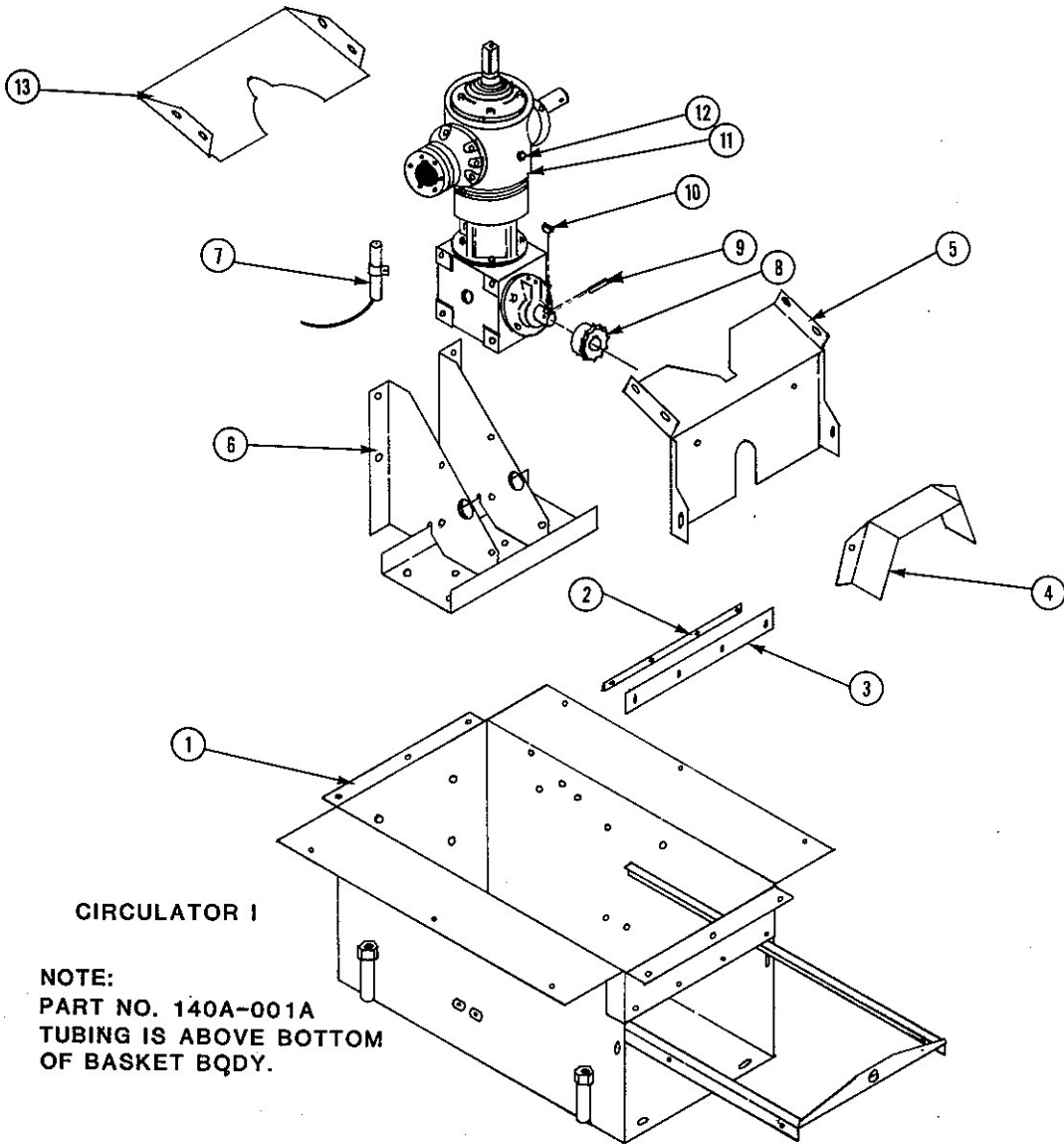

**OBSOLETE**