

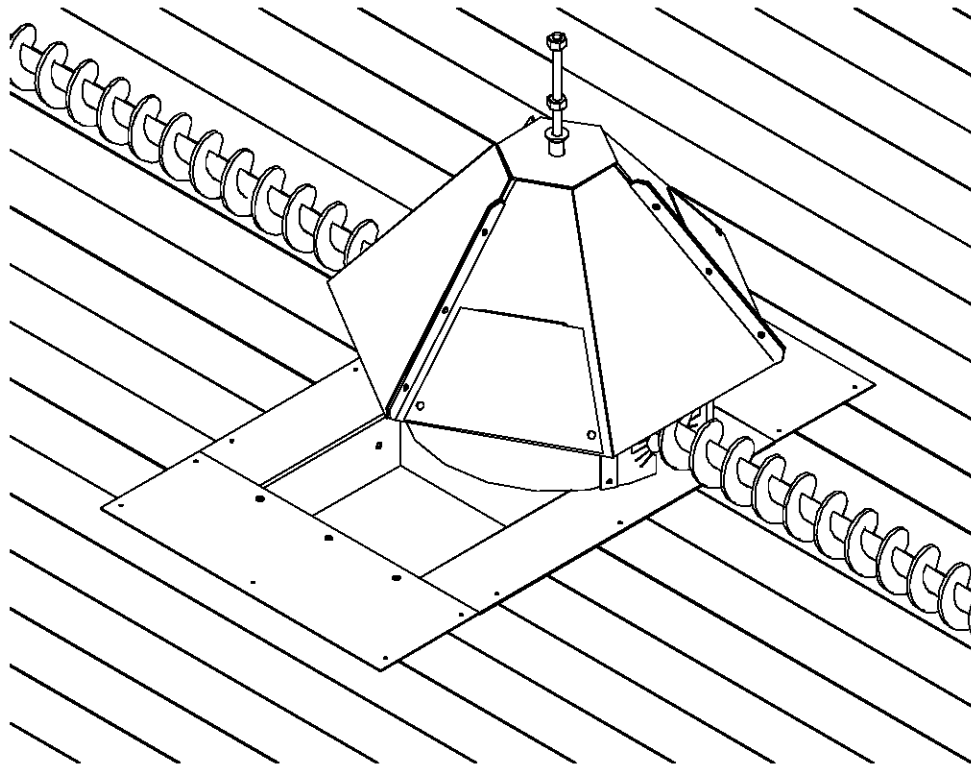

INSTALLATION INSTRUCTIONS



for

8" DRI-FLO 500 & 1000 HANGER BEARING UNLOAD & SWIVEL POWER HEAD (2007)

SHIVERS MANUFACTURING, INC.
614 W. English Street
Corydon, IA 50060
Ph. (641) 872-1005 ** Fax (641) 872-1593
www.shivers.com

P-12342
9/21/2015

Table of Contents

Introduction	2
Attention	3
Safety Information	4
Installation Safety	5
Safety Decals & Locks	5
Bin Layout	6-9
Installing Horizontal Unloader and Gearbox Basket	10-21
Installing Floor Doors.....	22
Tapered Sweep and Wear Track Installation	23-25
Installing Metering Ring & Bonnet	26-29
Installing Motor Mount & Accessories	30-36
Installing Safety Decals and Locks	37-42
Dri-Flo Installation Final Check	43

Introduction

Read this manual carefully. The information contained within this manual will instruct you on how to properly install and operate your equipment. Failure to do so could result in personal injury and/or equipment damage.

The Dri-Flo 500 and Dri-Flo 1000 are designed to remove dried grain from the bottom of the drying bin and transport it, via the horizontal unloader, to a desired destination. The removal of the grain is precisely metered so as to allow an even layer to be removed, without excessive center coning, which maintains optimum drying conditions. The more consistent the grain level, the more efficient the drying process will be.

Dri-Flo 500 will normally remove 500 bushels per hour and Dri-Flo 1000 will normally remove 1000 bushels per hour. These values will vary according to the size of the motor pulley, depth of grain, and moisture content of the grain. The amount of grain dried will depend on size of bin, number and size of burner/fans in use, depth of grain, moisture content of the grain, plenum temperature, as well as other factors.

The improved Dri-Flo Power Head will allow you to adjust the Jumpster take away auger with forward or side tilt. This allows for many unloading options.

Clamps are used instead of bolts between auger transitions. Many times the unloader can be set up for multiple discharge locations. The unit can be configured to dump into an air system, leg, truck, or bin.

Major Changes

- 1) Only one adjuster bolt to set the proper belt tension for the drive motor.
- 2) Clamps allow for quick adjustments of auger angles.
- 3) Jumpster take away auger can be adjusted with forward or side tilt.
- 4) Fliting can be pulled without taking off the drive motor or Jumpster auger.

If you are unsure of the correct configuration that would best suit your application, contact your SHIVVERS Dealer for more information.

Attention

The Shivers Dri-Flo will set up patterns of grain flow which puts extra stress on the walls and floor of the drying bin. **Additional floor supports are normally required for the drying floor. Bin sidewall stiffeners are often required.** Consult bin and floor manufacturer for their recommendations before installing and using the Shivers Dri-Flo. Shivers will not be responsible for structural failure of the drying floor or bin, or for any loss, damage, or injury relating to use of the Dri-Flo.

Large amounts of water are removed during the drying process. A way to remove this water from inside the drying bin is required. This is usually accomplished by installing roof vents. **We strongly recommend having the bin roof raised about 3/4" above the bin side wall.** This is especially important while drying when outside temperatures are below freezing. Having the roof raised will keep a lot of the condensation from running down the inside of the bin wall.

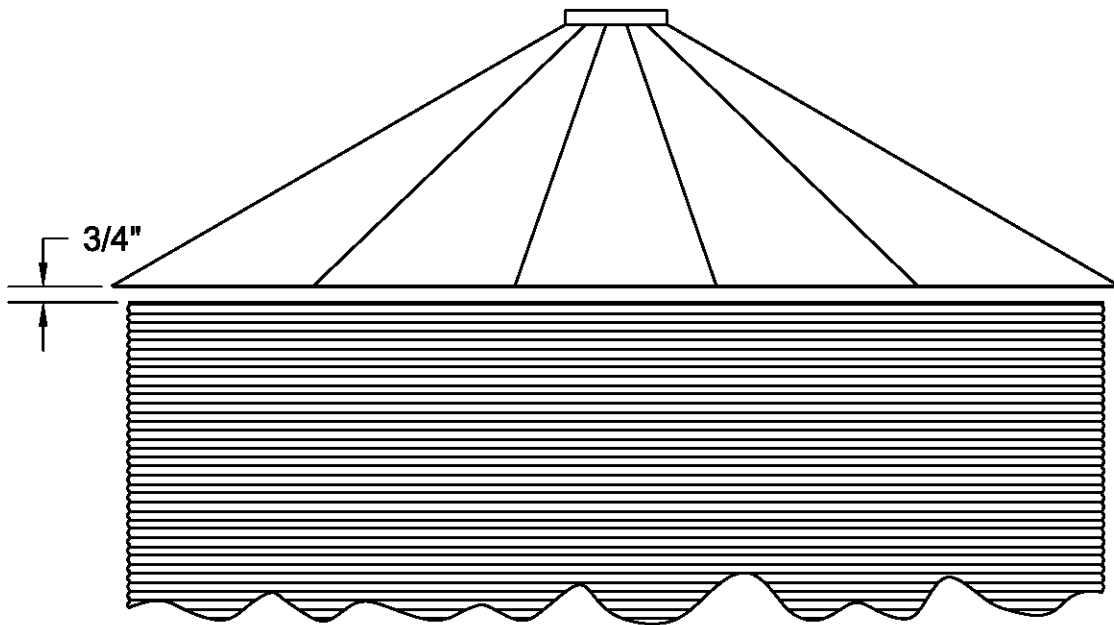

Safety Information

The user of this equipment must assume responsibility for his own safety and for the safety of those working with him.

If any items covered in this manual are not completely understood, or there is a concern with the safety of the product, contact Shivvers at the address shown on the front cover.

Read and understand the Operator's Safety Manual (P-10001), and all applicable operator's manuals, before working on Shivvers equipment.

Read and understand this manual completely before using this equipment.



Take note anytime this safety alert symbol appears. Your safety, and that of persons around you, is at stake.

The safety alert symbol will be accompanied by one of three signal words whose definitions are given as:

DANGER: Red and white. Indicates an imminently hazardous situation that, if not avoided, will result in death or serious injury. This signal word is to be limited to the most extreme situations, typically for machine components that, for functional purposes, cannot be guarded.

WARNING: Orange and black. Indicates a potentially hazardous situation that, if not avoided, could result in death or serious injury, and includes hazards that are exposed when guards are removed. It may also be used to alert against unsafe practices.

CAUTION: Yellow and black. Indicates a potentially hazardous situation that, if not avoided, may result in minor or moderate injury. It may also be used to alert against unsafe practices.

Installation Safety

Using a tagged padlock, lock off all sources of potential energy before beginning the installation!

All electrical wiring shall be installed in compliance with the latest addition of the ANSI/NFPA Standard 70, National Electrical Code, as a minimum requirement, and in compliance with local wiring codes as applicable.

Wiring must be done by a competent electrician. A licensed electrician is recommended, and must be used when required by local or state statutes.

The installation of this equipment will require special tools such as an oxy-acetylene torch (cutting torch), ladders, safety belts, power tools, and power cords with GFCI (ground fault circuit interrupter). The safe operation, use, and condition, of this equipment is the responsibility of the contractor, or persons involved in their use.

Avoid dusty conditions (especially on existing bins where grain has been stored), to prevent fires or explosions caused by combustion. Wear a dust mask.

Safety Decals and Locks

Field installable safety decals are supplied with this equipment. See section on Installing Safety Decals and Locks in this manual. If more decals are needed, contact the factory for additional ones.

Field installable safety lock kits are supplied with this equipment. See section on Installing Safety Decals and Locks in this manual.

Make sure all decals and the safety lock kits are installed on the system as shown in this manual and the Operators Safety Manual (P-10001) before the equipment is put in use.

Bin Layout

The concrete pad for the the drying bin should be as close to flat and level as possible. Make sure it is thick enough and has enough reinforcement so it will not crack and move. Consult the bin manufacturer for more information. A good, solid, flat and level foundation is required for the Dri-Flo to work properly.

See fan and burner installation manuals for instructions on concrete pads for them. See suggested layouts in this manual for orientation of fans, horizontal unloader, and control boxes. The suggested layouts show pad sizes for Shivvers Blue Flame dryers. They also show a Compudry Command Center for the control box. Your installation may have something different, but the orientation should be similar. Try to align the bin sheets so the fan/burner entrance collar(s) do not have to be cut through a seam.

The Horizontal Unloader must come out near the main entrance door of the bin. The control box must be within line of sight of the bin's main entrance door.

There must be a main electrical disconnect switch. This switch must shut off all electrical power to the drying system. It must have the capability of being locked in the OFF position. It must be located near the bin's main entrance and within line of sight of the control box. This disconnect switch is NOT supplied by Shivvers, but can be obtained locally.

A lockable disconnect switch for the Machine (Circu-Lator or Dri-Flo) Motor is required near the bin entrance. This disconnect switch is NOT supplied by Shivvers, but can be obtained locally.

A switch to control the drying bin spreader is also required, but not supplied by Shivvers.

Since the Shivvers drying system can operate at temperatures up to 200° F, all sealants in the plenum area must be able to withstand this temperature. Ordinary plastic roofing cement or tar will soften and should not be used. Possible materials to use are:

- (1) Black Jack #1010, Neoprene Flashing Cement, by Gibson-Homans
- (2) Regular 100% Silicone Caulking
- (3) Stretch-a-Seal (™), Bin and Elevator Sealant, by Farm Products Direct
(Follow manufacturer's instructions) Ph (800)669-9314
- (4) Rubberflex Binseal Ph (800) 817-2986

All air leaks in the bin must be sealed off. The sealant should be applied from the inside of the plenum area, if at all possible. If it is applied from the outside, plenum pressure will probably blow it out.

Bin Layout (cont'd)

Shivvers Dri-Flo 1-Fan Layout

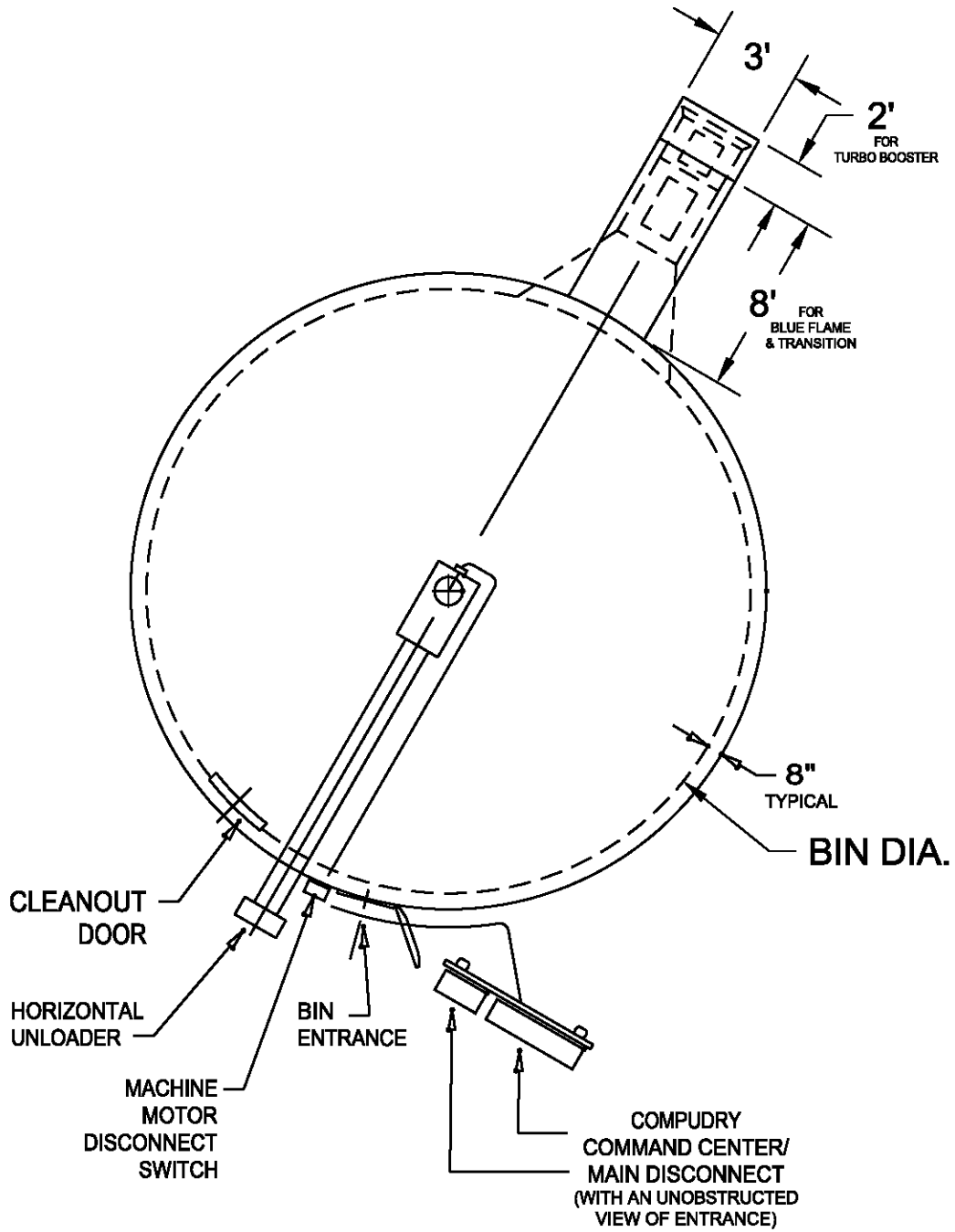

FANLYT-1.DWG

Bin Layout (cont'd)

Shivvers Dri-Flo 2-Fan Layout

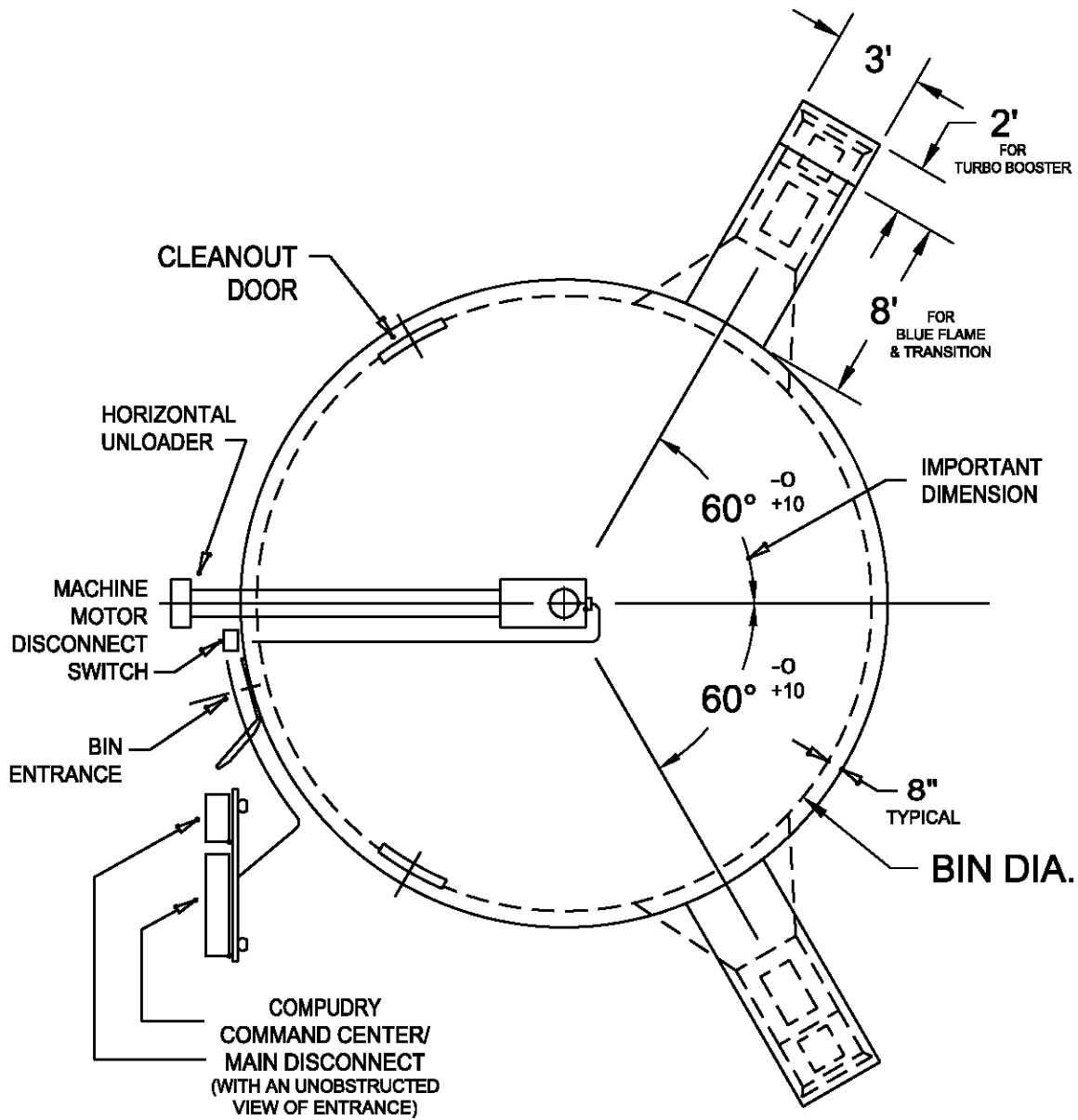

FANLYT-2.DWG

Bin Layout (cont'd)

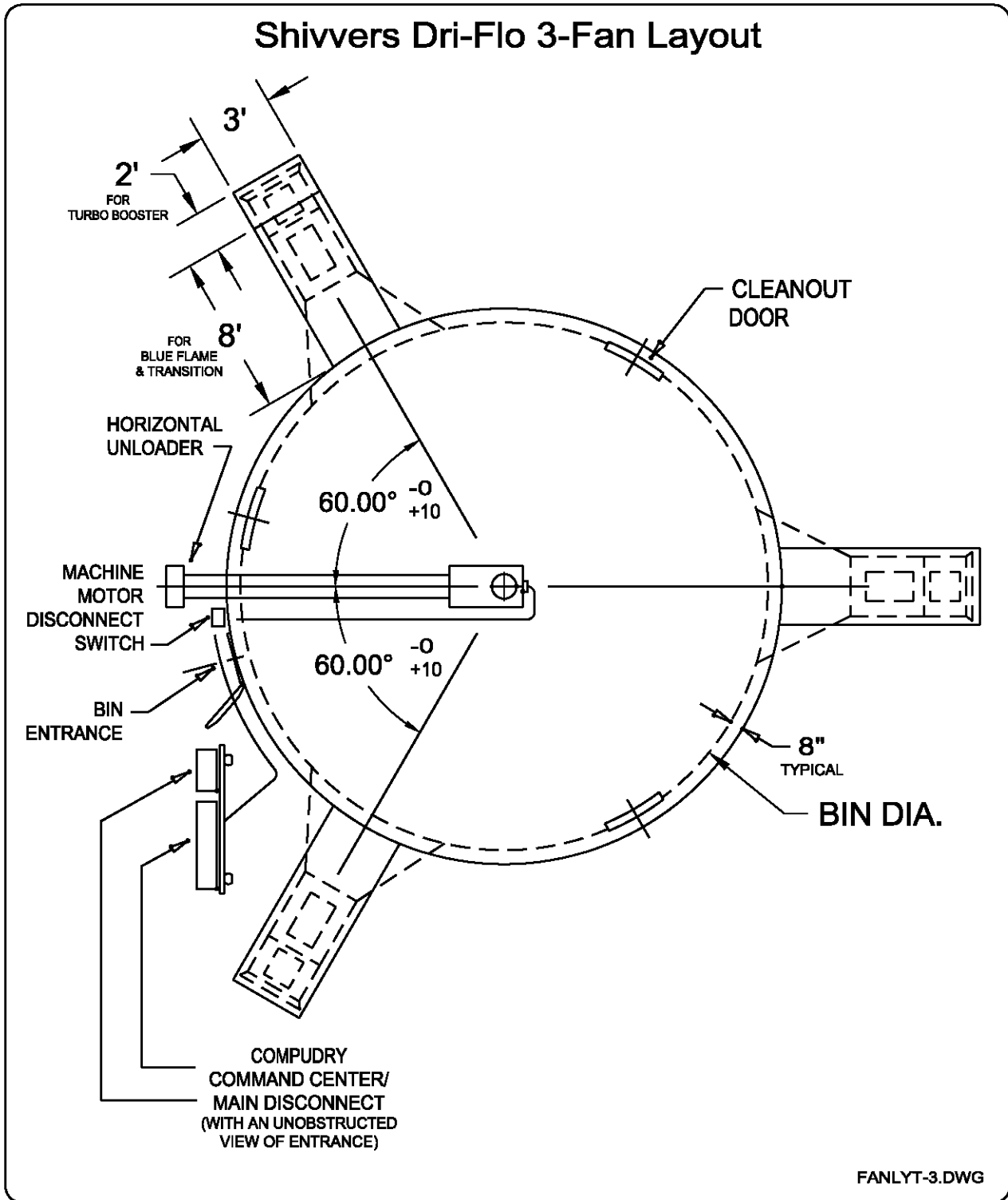

Installing Horizontal Unloader and Gearbox Basket

Step 1:

For installations in existing bins, it is recommended that the floor be removed. If the old floor is going back in, number the individual floor pieces for convenience of reinstallation. The entire concrete bin floor should be cleaned.

Step 2:

Determine the location where horizontal unload tube will project through the bin sidewall. It should be within sight of the bin entrance and the dryer controller. At this location, measure down 8-1/2" from where the top of the floor will be. This will be the center of the horizontal unload tube.

FOR SHIVERS FLOOR AND SUPPORTS			
Leg Designator	Leg Height	Top of Floor	Concrete floor to Center of Horizontal
* S	11.46"	12-5/8"	4-1/8"
M	15.68"	16-7/8"	8-3/8"
T	16.25"	17-7/16"	8-15/16"

* = Not recommended for high temperature drying. It will be necessary to grind off projections on bottom of gearbox basket and to shorten bottom of faceplate.

Hold the faceplate pieces against the bin wall, with the control rod holes on top, and mark all holes on the bin wall. Cut a keyhole shape in the bin wall for the unload tube and control rod. Make sure the hole is large enough to allow the hanger bearings to go through. Make sure the faceplate will cover the hole that is cut.

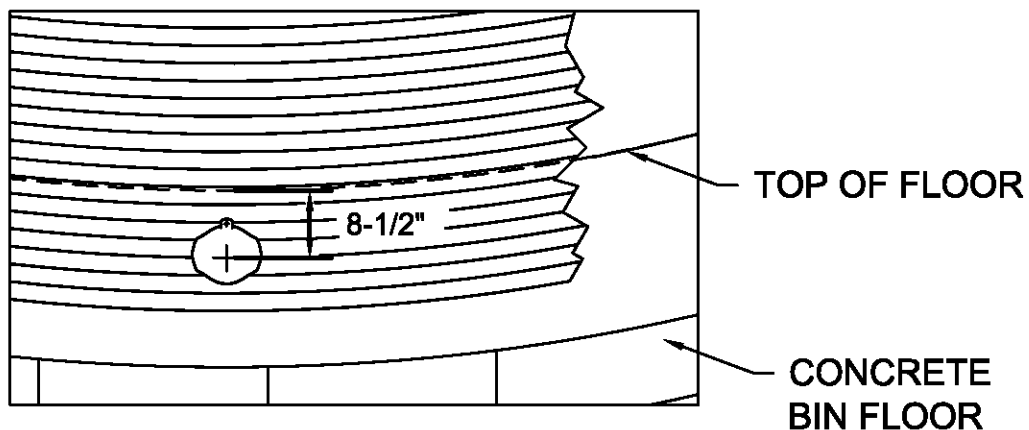

Installing Horizontal Unloader and Gearbox Basket

Step 3:

Insert the horizontal unload tube through the hole cut in the bin wall. Be sure that the Horizontal Unload Transition opening is facing the right side and the hanger bearings are on the top center. Do not attach faceplate yet.

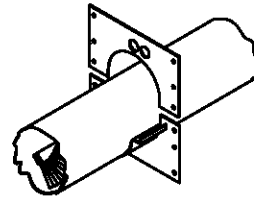
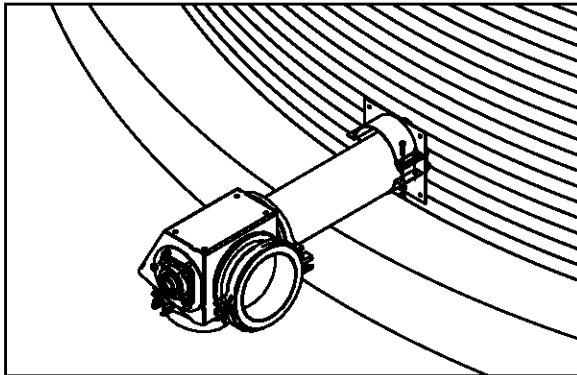

TWO PIECE
FACEPLATE
656-031P TOP
656-033W BOTTOM

Step 4: Prepare gearbox and basket for installation.

Remove the metering ring by loosening the bolts from the top of the gearbox. Replace lockwashers and bolts back into the gearbox. Check the gearbox to insure it is lubricated. Remove the shipping wire that holds the top gearbox to the bottom gearbox. Screw jam nuts, from the 222-085A Basket Hardware Sack, on the 3/4" x 12" support legs approximately 9". Screw the support legs, with jam nuts, into the basket until the top of the basket will be at about the same height as the drying bin floor.

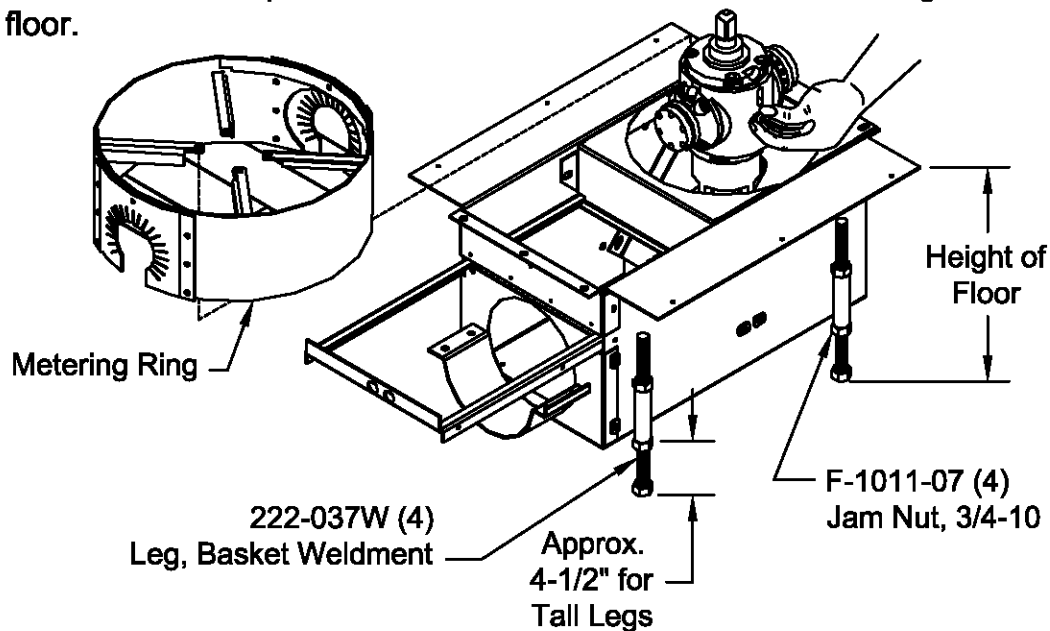

Installing Horizontal Unloader and Gearbox Basket

Step 5:

Install the front plate on the basket with hardware from 222-085A, Basket Hardware Sack, as shown. The bottom lip on the front plate goes inside the basket and the sides of the front plate go outside the basket. Temporarily remove the flipper from the bottom gearbox.

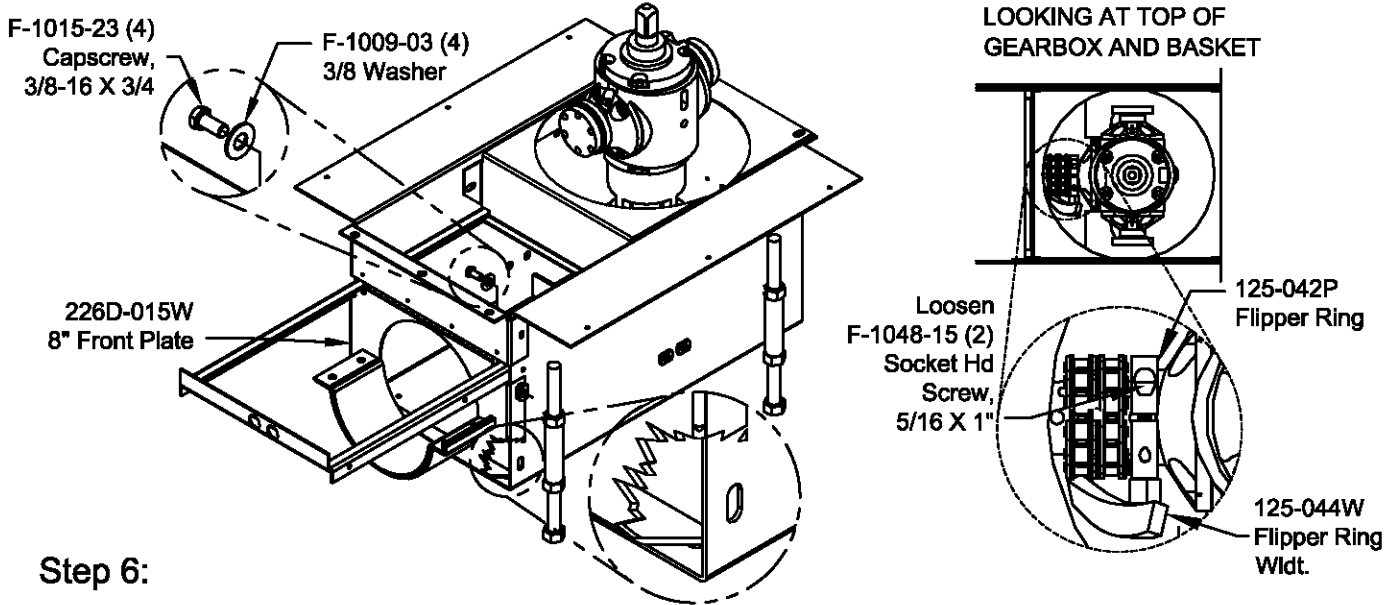

Step 6:

Slide the horizontal unload tube into the basket. Temporarily clamp the horizontal unload tube to the basket with hardware from 222-085A, Basket Hardware Sack. Do not tighten yet. The end of the unload tube should be about flush with the inside front plate of the basket.

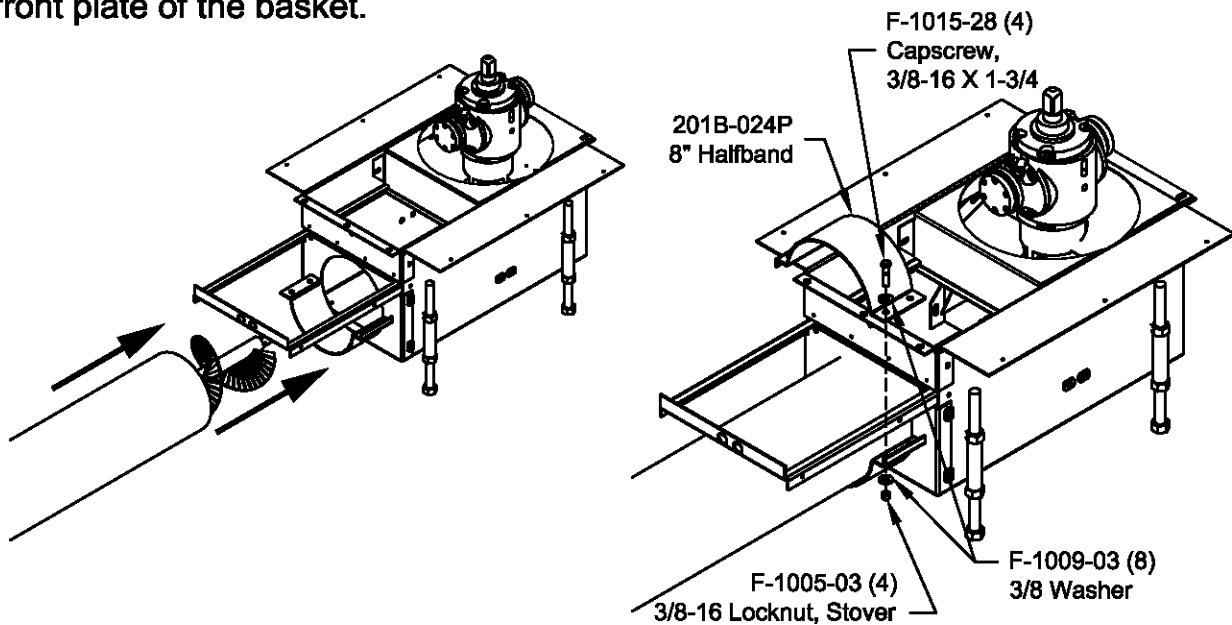

Installing Horizontal Unloader and Gearbox Basket

Step 7: Center and adjust basket:

Position the basket so the square shaft on the gearbox is centered in the bin. Check for center in at least four directions around the bin. Adjust the basket support legs until the basket is at the proper height (top of floor) and level in all directions. Shivers part number 423-351-001A is for a mounting bracket that holds a laser level onto the gearbox. **This would be a good time to check that the gearbox is square to the floor using the 423-351-001A Gearbox Laser Mount Kit.** It can be used to make sure the gearbox is square with the concrete bin floor. Weight must be carried by all four support legs. Using a marker or spray paint, mark around the support legs for an easy verification that the basket remains in the center of the bin.

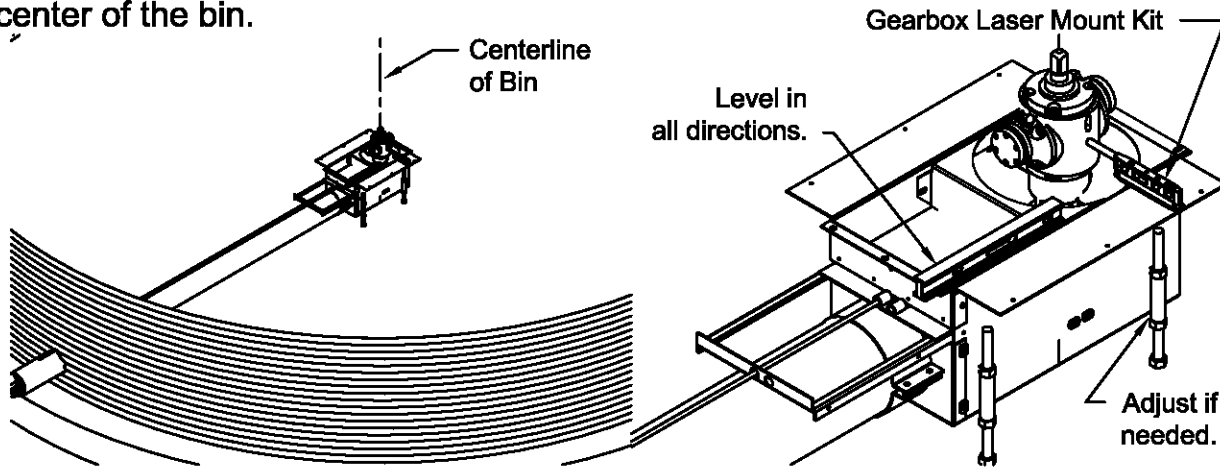

Step 8:

Place level on the horizontal unload tube and temporarily support outside end to level. Trim faceplate hole if necessary. Leave room between temporary support and bin wall so faceplate holes can be drilled and bolts tightened.

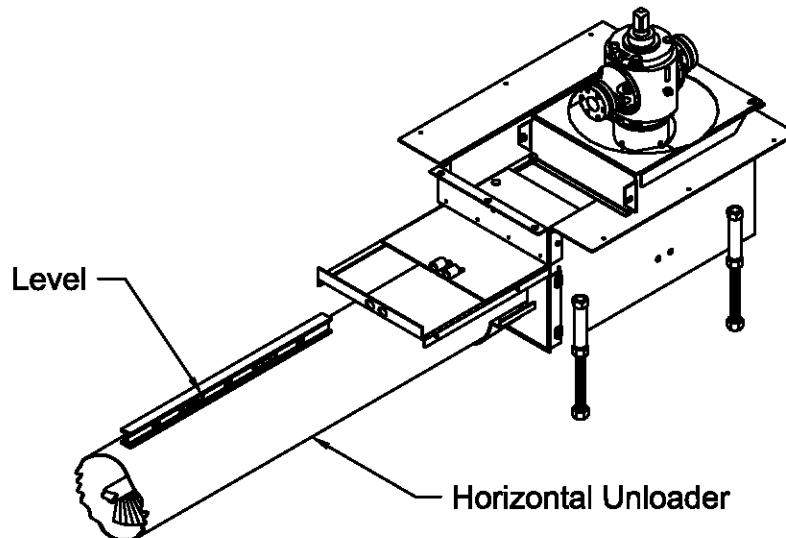

Installing Horizontal Unloader and Gearbox Basket

Step 9: Install Mounting Stand (& Dri-Flo Brace Assembly, See P-12283) Two types of stands are provided. Use one or both depending upon your site layout.

Attach stand and two halfbands around horizontal discharge tube. Use hardware from 222-059A, Horizontal Stand Sack. Adjust height, allowing stand to support all weight. (Stand is designed to set upon a solid surface. It is recommended to dig in a footing under this stand, below the frost line.) Another stand is supplied in the chain and pop parts box for bins 36' and larger in diameter. Place it between the bin wall and the basket. To install the Dri-Flo Brace Assembly, follow instructions, P-12283, provided with the kit (672J-001A).

Mounting Stand

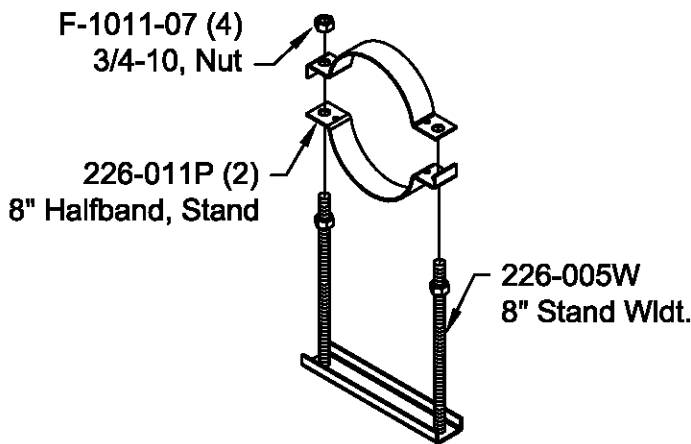

Dri-Flo Brace Assembly

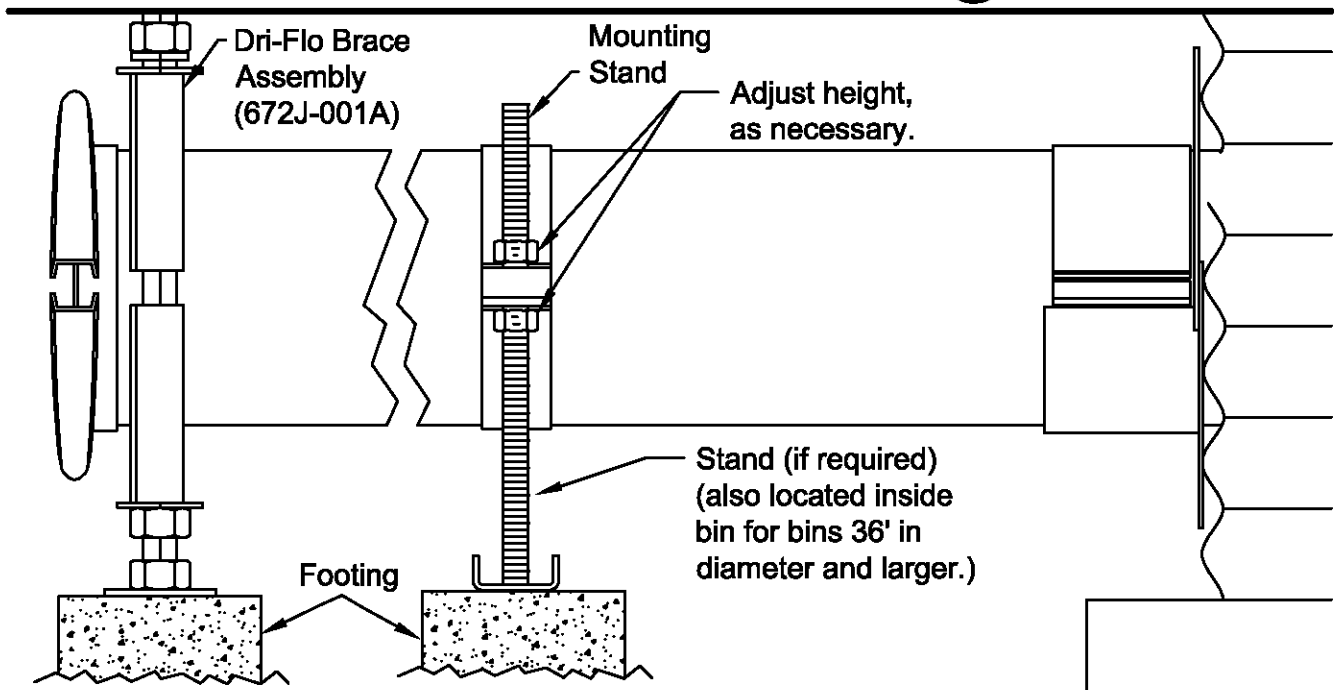
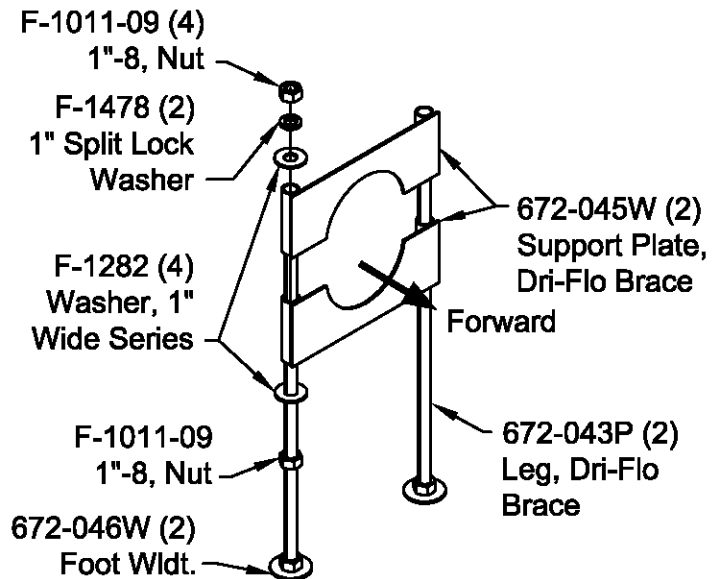

Installing Horizontal Unloader and Gearbox Basket

Step 10:

Using the 222-029A sack labeled "Chain Coupler," connect the drive shaft of the horizontal unloader to the gearbox input sprocket.

1

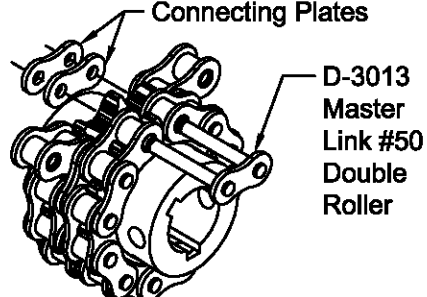

Connecting Plates

D-3013 Master Link #50 Double Roller

Slide pins of master link through chain farthest from gearbox with chain closest to gearbox folded back. Insert 2 connecting plates between chains, while sliding in master link pins.

2

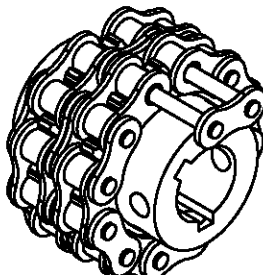

Fold inside chain back onto sprocket and completely insert master link pins.

3

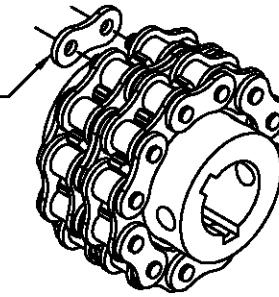

Connecting Plate

Place another connecting plate on master link pins.

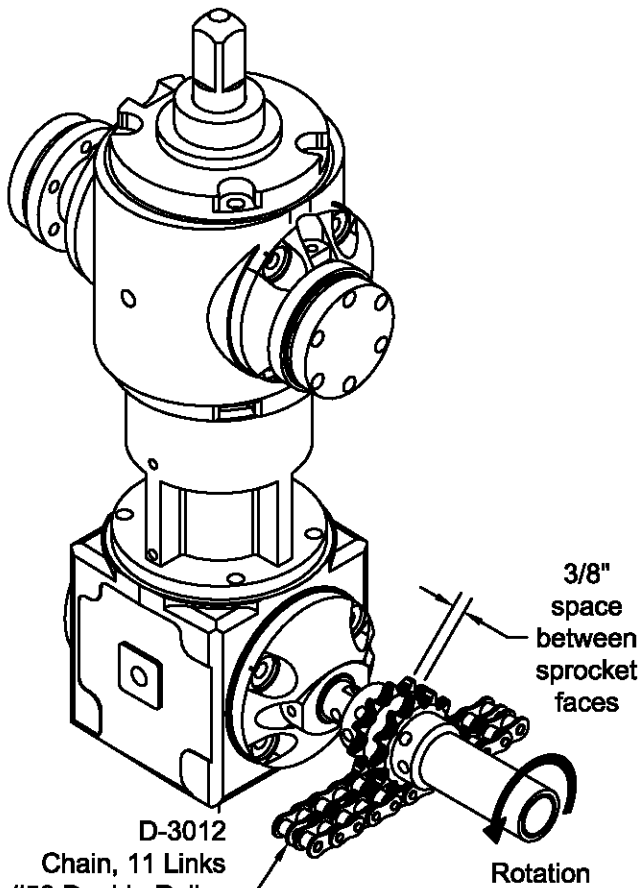

3/8" space between sprocket faces

D-3012 Chain, 11 Links #50 Double Roller

Rotation

4

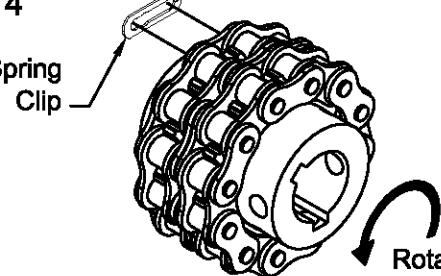

Spring Clip

Rotation

Install spring clip onto master link pins with solid end (not split end) facing toward sprocket rotation. Make sure spring clip is securely seated into master link pin grooves.

Installing Horizontal Unloader and Gearbox Basket

Step 11:

Temporarily slide the 15" 3 groove pulley onto the power head. Slide on the 3-jaw clutch. Make sure there is enough of the 1" drive shaft extending beyond the 15" pulley to allow complete disengagement of the 3-jaw clutch from the 15" pulley. If not, the complete horizontal unloader must be pushed inward (into the basket), until clearance is achieved. Loosen the clamp on the horizontal unload tube at the front of the basket and pull the tube in or out until the 3-jaw clutch operates properly (full engagement and disengagement).

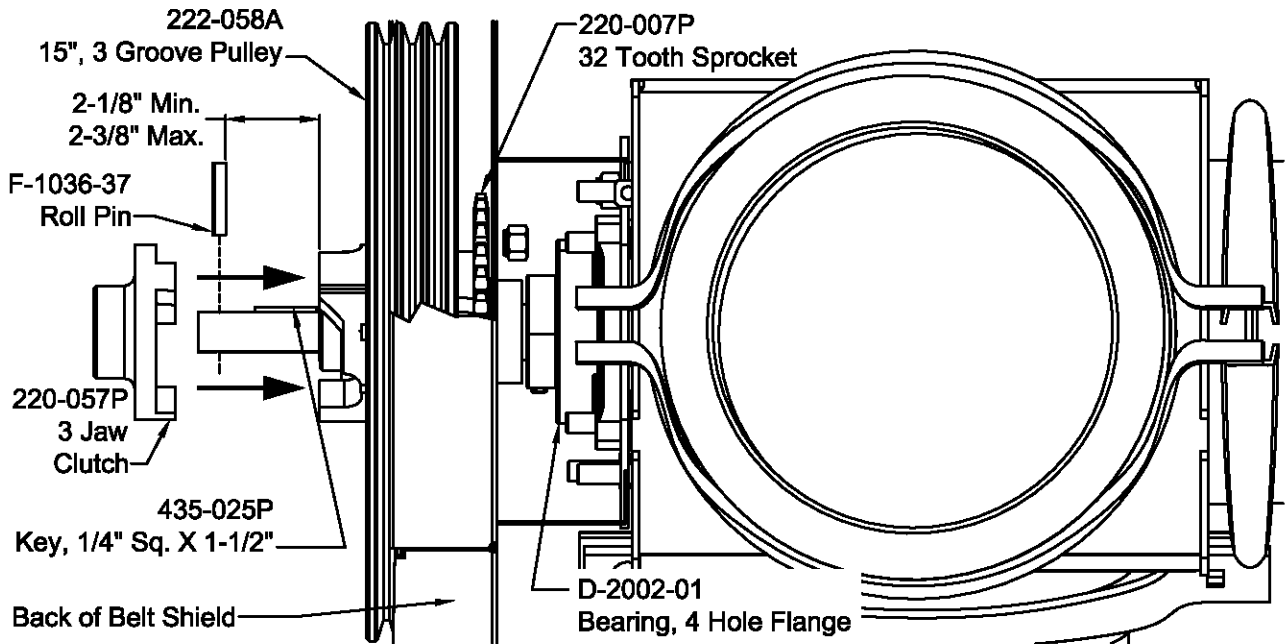

Make sure there is 1/8-1/4" clearance between the 1" drive shaft sprocket and the 1-3/8" unloader fight weldment tubing inside the basket. An O-ring is applied at the factory to help maintain this clearance. Once the unloader is clamped to the basket, the O-ring does not have to remain in place.

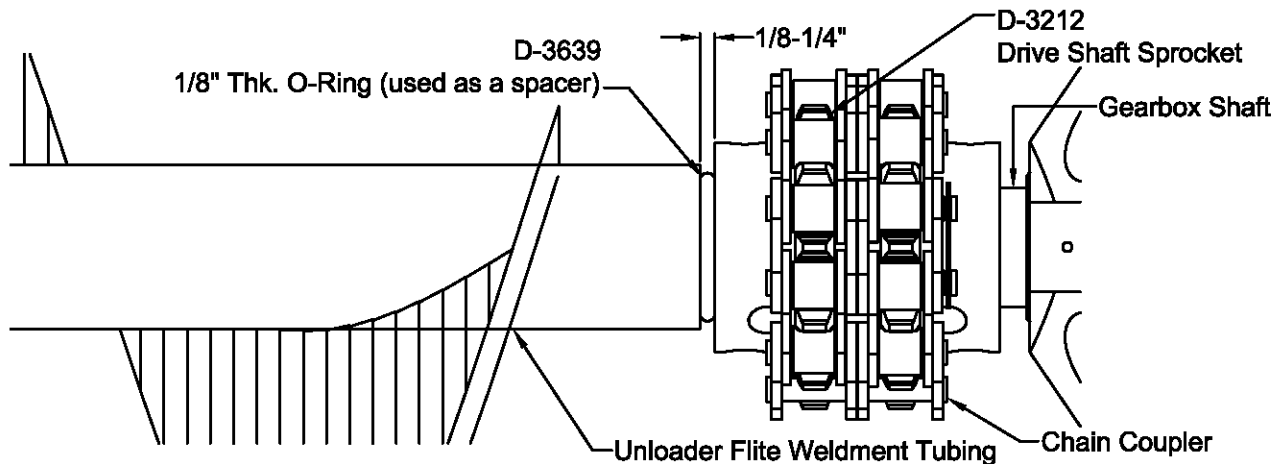

Installing Horizontal Unloader and Gearbox Basket

Step 12:

Drill bolt holes for faceplate. Apply high temperature sealant and mount faceplate to bin wall using hardware in "faceplate" sack (656-036A). Do not tighten the halfband clamp yet.

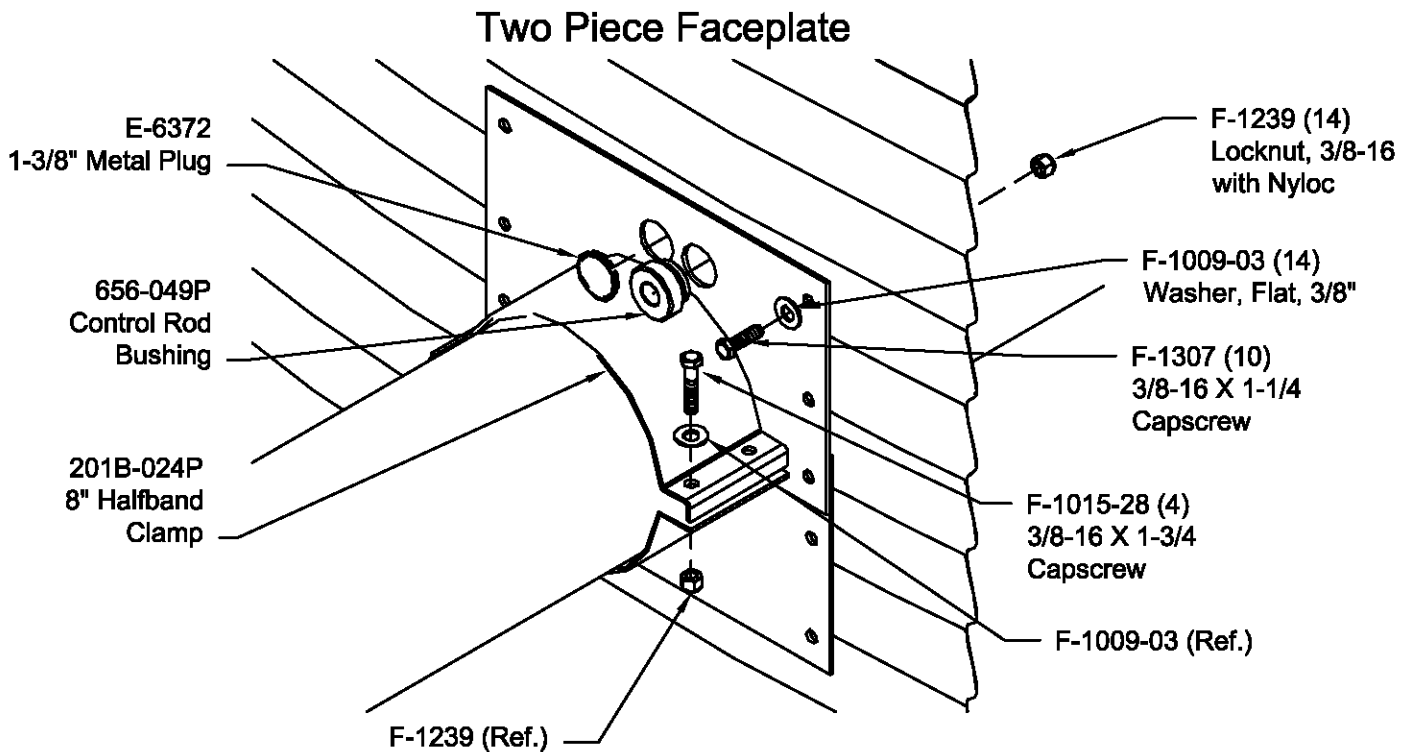

Installing Horizontal Unloader and Gearbox Basket

Step 13:

Make sure the line shown below is straight up in bin. The hanger bearing grease zerks will be pointing about 5° off center. Then tighten halfband clamp at the basket. Recheck that the gearbox and basket are still in the center of the bin and tighten the faceplate clamp. Replace the flipper ring that was removed in Step 5.

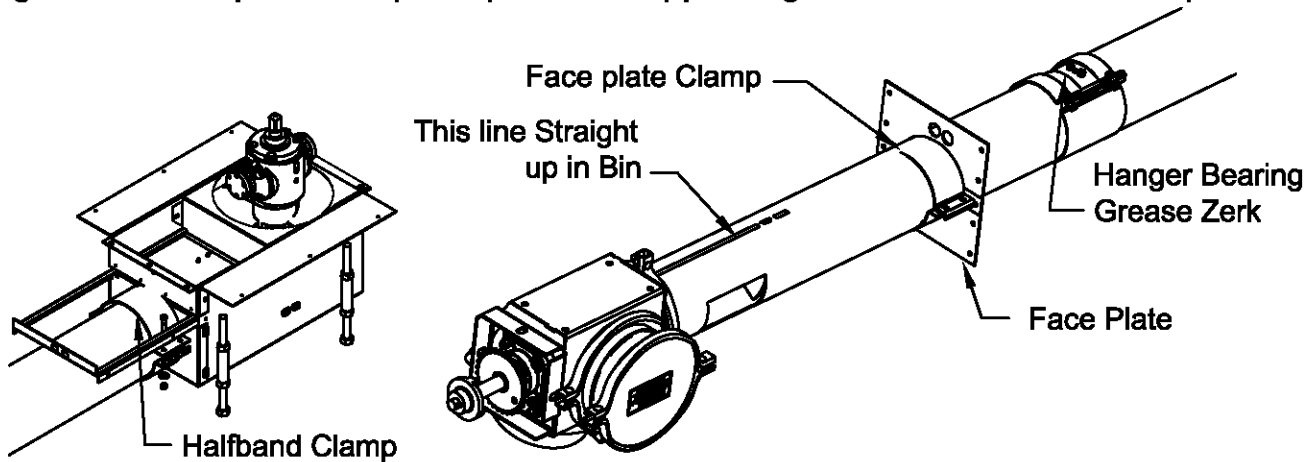

Step 14: Optional Intermediate Well (For more details see Intermediate Well Instructions, P-11584).

If an intermediate well is to be installed, attach it to the horizontal unloader now. Make sure the well is not placed where the tapered sweep auger track will be. Track location will depend on type of sweep auger. For bins under 29' diameter, there is not an inside track. For bins 29' to 33' diameter, the center of the inset wheel track will be either 115" or 145" from the gearbox base, depending on the sweep type. For bins over 33' diameter, the inset wheel track will be either 142" or 145" from the gearbox base. Measure the sweeps to double check inset wheel location. Once the intermediate well is installed, attach a 1" pipe control rod (not included, supplied by dealer) to allow independent operation of intermediate well slide gate. Hanger bearing augers will use the offset holes in the basket, intermediate well, and faceplate, to allow clearance for hanger bearing grease zerks.

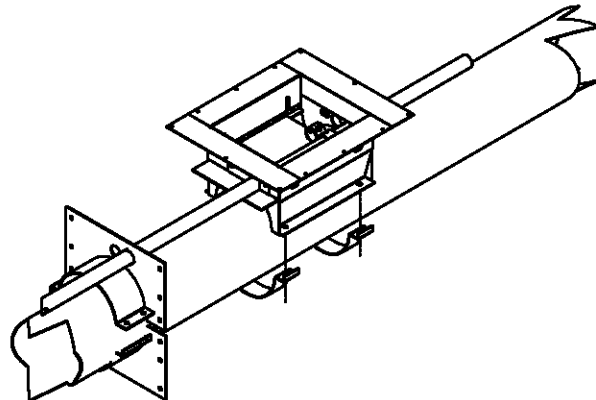

Installing Horizontal Unloader and Gearbox Basket

Step 15:

Install slide gate into the basket as shown. Approximately center control rod guide on unloader tube (guide may not be required if intermediate well is used). Bins over 34' in diameter may require two control rod guides. One is located in the parts box and one is located in the chain and pop parts box. If an intermediate well is not used, install the 656-049P, control rod bushing, into the face plate. Install a E-6372, 1-3/8" metal plug, into the unused face plate hole. Slide control rod through face plate, intermediate well (if used), control rod guide, and basket guide. Screw control rod into slide gate and check operation. Attach the slide gate opener (91B-001A, see P-8401 for more details).

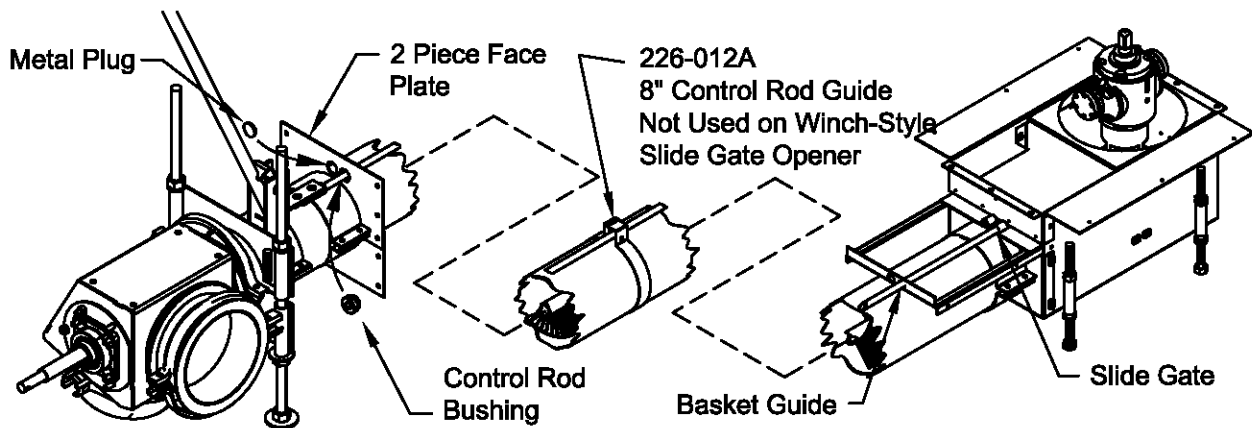

Step 16:

Slide lever rack over control rod and screw pipe cap on end of control rod. With lever rack against pipe cap, drill a 5/16" diameter hole through control rod at hole in lever rack. Install roll pin through both parts. With slide gate closed, center lever pivot with center of first hole in lever rack and clamp halfbands securely. Slide pivot pin through lever pivot and lever and install cotter pins on each side.

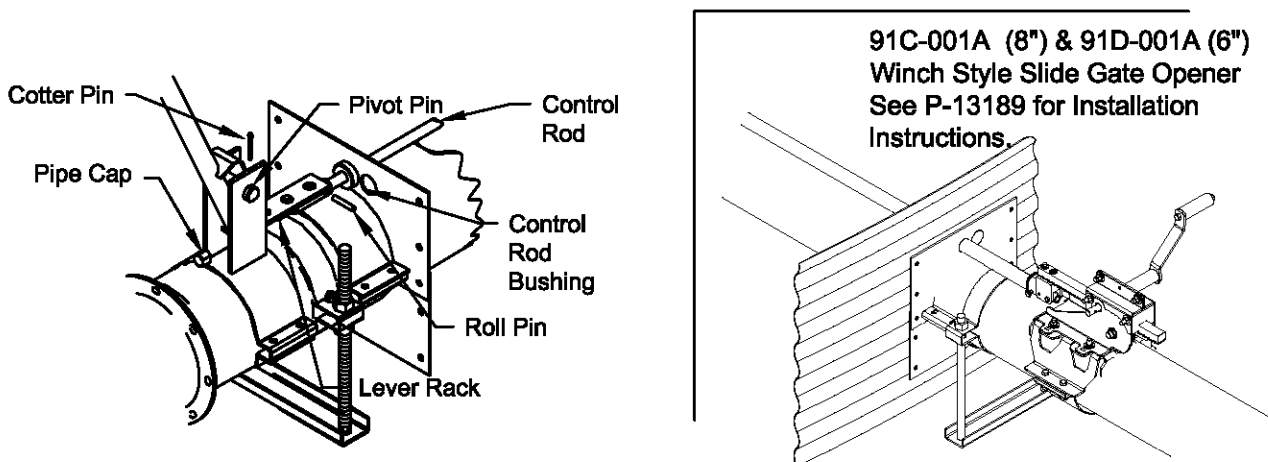

Installing Horizontal Unloader and Gearbox Basket

Step 17: Install conduit for gearbox Hi-limit.

The gearbox Hi-limit will shut off the drying fan(s) if it gets above 240° F. What the gearbox Hi-limit will wire to depends on the type of control and how many fans are used in the installation. If a Compudry Command Center is used, the gearbox Hi-Limit will always wire to it. If 2 or more fans are used, the gearbox Hi-limit will wire to either the dryer control box or a Grain Hi-limit Control box. Only if a control other than a Compudry Command Center is used, and there is only one fan on the bin, will the gearbox Hi-limit go directly to the fan. The important thing is to get the conduit installed before the bin floor is in place. The wire can always be routed wherever it needs to go once it is on the outside of the bin. If the conduit is not going to be in-line with the horizontal unloader, it may be better to wait until the floor supports and rails are in place to route the conduit so it doesn't interfere with floor support placement. Use the high temperature wire (641-046A) supplied for under the floor. Once outside the bin, any appropriate electrical control wire can be used. Pull 2 of the high temperature wires through the conduit. Connect each wire to a gearbox Hi-limit wire in the junction box on the back of the basket. Use regular wire nuts to make the connection. Refer to installation manual for dryer control used on where to connect the other end of the gearbox Hi-limit wires.

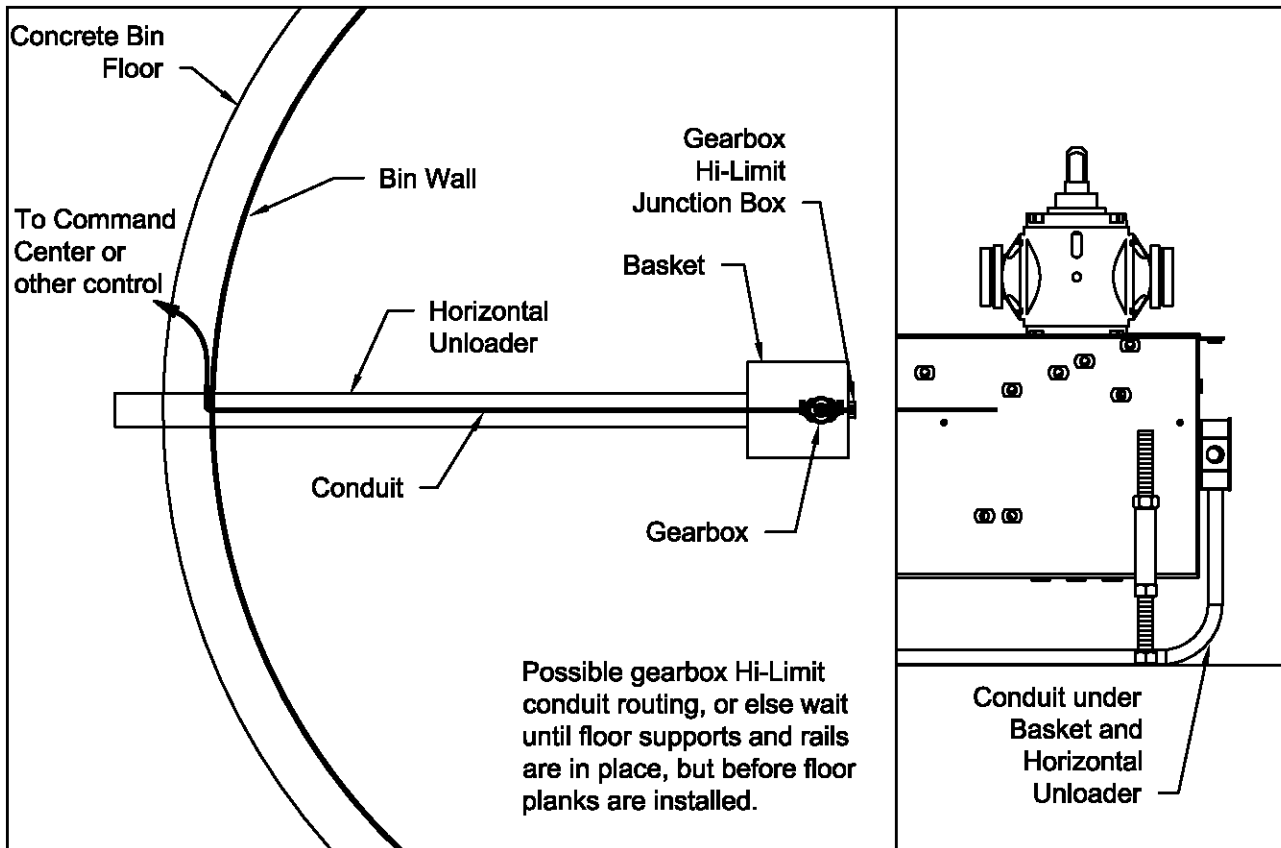

Installing Horizontal Unloader and Gearbox Basket

Step 18:

Follow instructions provided with floor and supports to install perforated drying floor.

Step 19:

Make sure enough of the floor planks are cut out to provide access to Gearbox Hi-Limit junction box and basket support legs. **This would be a good time to check that the gearbox is square to the floor using the 423-351-001A Gearbox Laser Mount Kit.**

Bolt the end plates to the basket with 3/8" hex socket button head capscrews from 222-085A basket sack. Drill required holes to pop rivet end plates and basket sides to floor planks.

NOTE: 3/8" hex socket button head bolts must be used for sweep auger clearance.

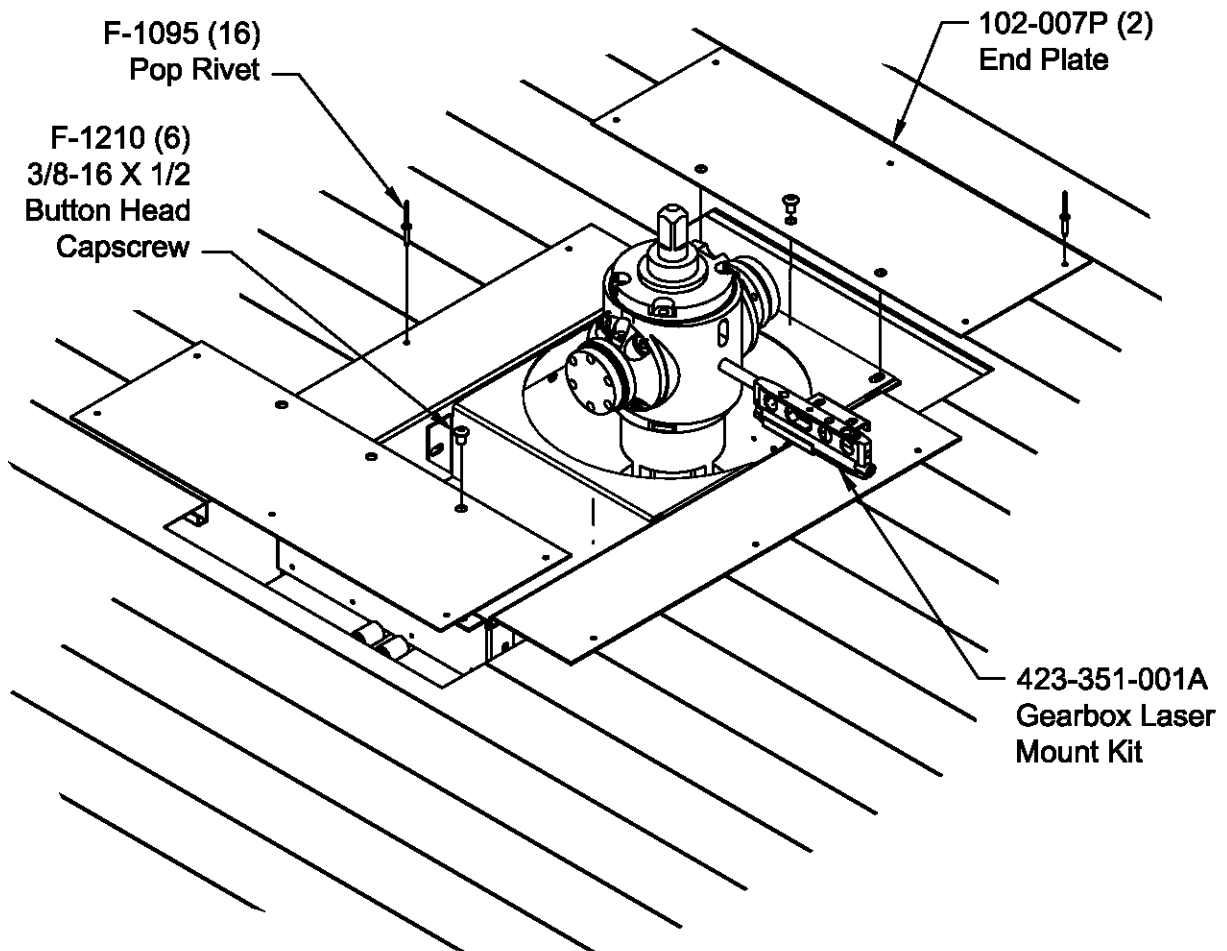

Installing Floor Doors



Disconnect and lock-out all power before installing these Floor Doors over Hanger Bearings or servicing below the floor.

Following the directions found in the floor door box, mark out a rectangle 17" long by 15" wide and cut. Lay frame in place and pop rivet. Fasten down Floor Door using screws provided.

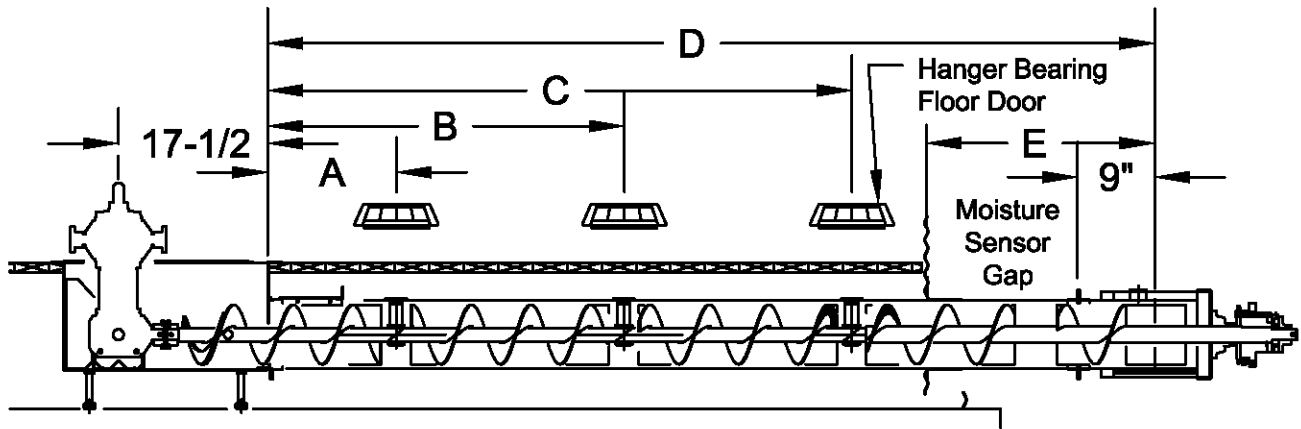

698 Series 8" Dri-Flo Horz. Unloader w/1" Drive Shaft,
Replaceable Hanger Bearings

DF500,1000 w/Hngr Brgs	Bin Dia.	Hngr Brgs/Floor Door Positions From Inside of GB Basket			Basket to Discharge	Bin Wall to Discharge
		A	B	C		
698D-001A	24FT	90-3/8"			172"	45-5/8"
698E-001A	27FT	38"	122"		191"	46-5/8"
698F-001A	30FT	56"	116"		209-1/2"	47-1/8"
698G-001A	33FT	68-1/2"	152-1/2"		233-1/2"	53-1/8"
698I-001A	36FT	68-1/2"	176"		257"	58-5/8"
698J-001A	42FT	103"	211"		304"	69-5/8"
698K-001A	48FT	55"	151"	247"	328"	57-5/8"

Tapered Sweep and Wear Track Installation

Step 1:

- a. Remove caplugs from tapered sweep's coupler. Remove all debris from the tapered sweep's coupler and outside surfaces of the gearbox base and flange.
- b. Pack the inside of the tapered sweep's coupler and coat the outside of the gearbox's base and flange with our recommended high temperature-rated grease, Chevron Ulti-Plex Synthetic Grease EP or equivalent. (Shivvers # C-6188 (14oz Tube).
CAUTION: USE ONLY THIS GREASE. Other greases may harden in the coupler, causing sweeps to break.

Step 2:

Bolt the tapered sweep auger(s) to the gearbox as follows: See Figure A

- a. 3/8-16 sockethead capscrew (F-2158) and locknuts (F-1005-03) or 7/16-20 x 2 (F-2175) and 7/16 jam nut (F-2176) for 712 Series Sweeps, are provided in the decal package. This bolt and nut must be used.
- b. Position the sweep's coupler onto the output shaft.
- c. Insert bolts into sweep's coupler, through the output shaft, and start the threads into the flange, then start a nut onto the end of each bolt.
- d. Tighten the bolts down to about 36-40 ft/lbs.
- e. With a hex wrench on the head of the bolt, tighten the nut, in effect double-nutting it with the flange. The bolt should have threads seen on the outside of the nut. As added protection from loosening, it is recommended that you hit the thread next to the nut with a punch to deform the thread, locking it in place.
- f. Repeat the above process to install all tapered sweeps as required.

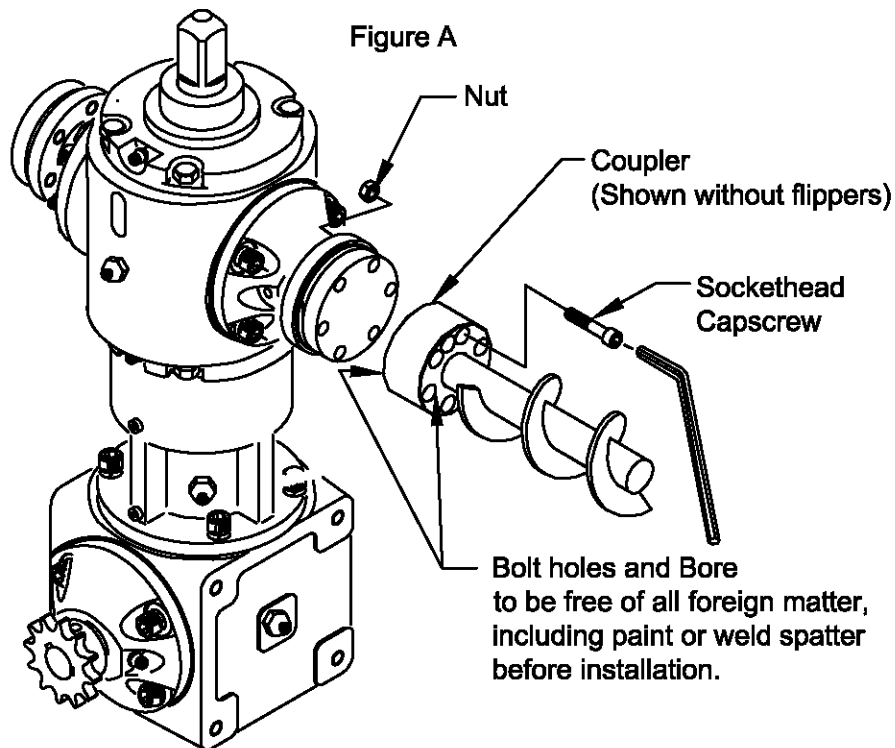

It is recommended that these bolts and nuts not be re-used.

See your dealer or Shivvers for replacement of hardware sack #635-014A for 3/8 hardware or #712-010A for 7/16 hardware.

Tapered Sweep and Wear Track Installation

Step 3:

There should be flex in the coupling after the sweep auger is bolted to the gearbox. Check to make sure the sweep can be lifted a minimum of 6" at the outer end of bin without bending the sweep auger shaft. Check this in at least 4 places around the bin, especially in-line with and perpendicular to the horizontal unloader. If the amount of flex is not uniform around the bin, the basket legs will have to be adjusted.

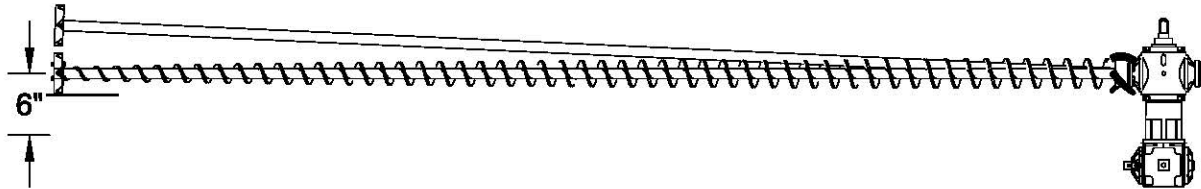

Step 3A: Universal Outside Track (Narrow)

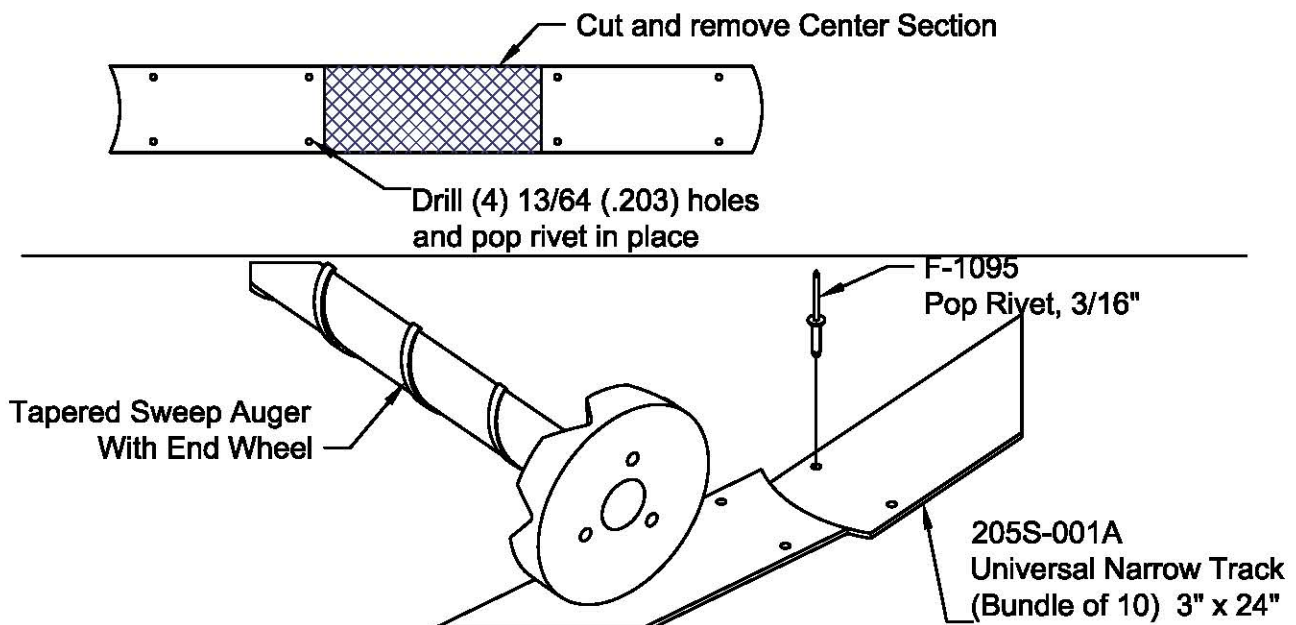

Bin diameters 29' - 33' do not normally use an outside track. For all other bin sizes or for all sweep augers with an outside wheel, install an outside track. **Lay the track sections so that ends butt up against each other (no cracks between sections), flush and smooth (one end not higher than another), with the sweep auger wheel riding the center of each end.** As each section is laid in place, move the tapered sweep along the track to insure that curvature and location are correct, then fasten securely with 3/16" pop rivets. Pop rivets are provided in the 450X-001A series Chain and Pop Rivets Box. Drill additional holes and pop rivet track down, as necessary, to insure a firm, smooth track. Do not use self-drilling screws. They will loosen with time. **Do not allow the wheel to run over a pop rivet head.** The last section of track usually must be trimmed to size. To trim, remove a straight section out of the center of the track, as shown below. Drill 13/64" (.203") holes and pop rivet both ends down.



Tapered Sweep and Wear Track Installation

Step 3B: Universal Inset Track (Wide)

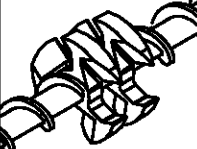
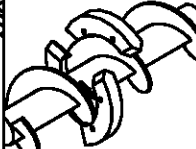
The tapered sweep auger for bins 29' diameter and over have an inset wheel that moves along a wide wear track mounted on the bin floor. These track sections must be laid so as to form a smooth, firm path along the bin floor on which the tapered sweep auger can move. **Lay the track sections so that the ends butt up against each other (no cracks between sections), flush and smooth (one end not higher than another), with the inset wheel riding the center of each end.** As each section of track is placed on the floor, move the tapered sweep along the track section to insure that the inset wheel will be centered as it runs along the track. After checking the location, mount the track with 3/16" pop rivets. Drill additional holes and pop rivet track down, as necessary, to insure a firm, smooth track. Do not use self drilling screws. They can loosen with time. **Do not allow the wheel to run over a pop rivet head.** The last section of track usually must be trimmed to size. To trim, remove a straight section out of the center of the track. Drill 13/64" (.203") holes and pop rivet both ends down. See illustration from Step 4A on the previous page.

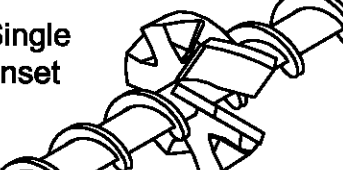
Track Bundle Part #	Track Style & Dimensions	Inset Wheel Location From	Inset Wheel Style	
205R -001A 5 Pieces Per Bundle (205-014P) (individual)	 6" x 24"	Gearbox Base 9'-7"	Double Inset 	Bolt-On Inset 
		11'-10"	Double Inset 	Bolt-On Inset 
		12'-7/8"	Single Inset 	

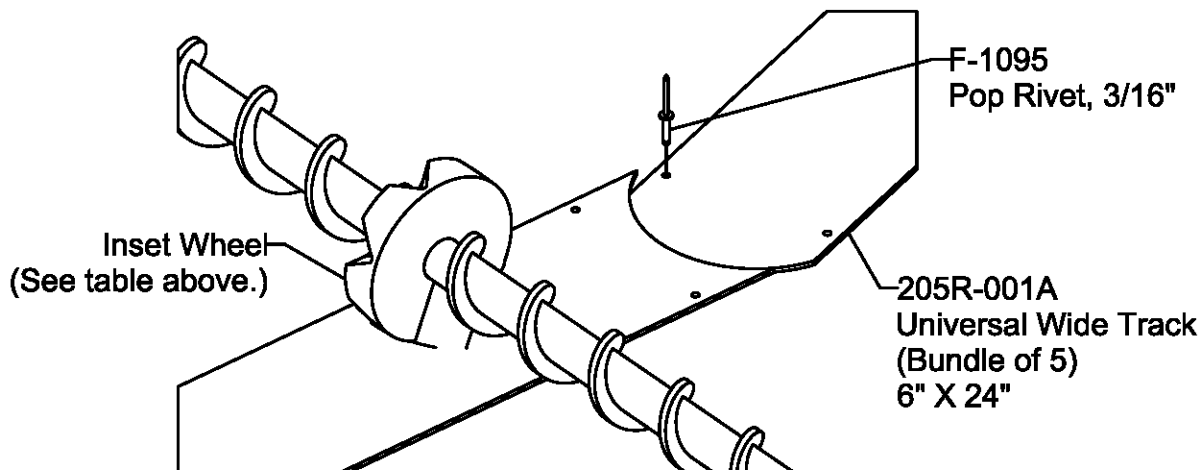

Installing Metering Ring and Bonnet

Step 1B: Gearbox Access (Before putting on Metering Ring)

The lower housing of the gearbox can be accessed by sliding back the Access Covers (69-462P) on the Slope Plate (125-048P). One cover will allow the vent plug to be removed and the other cover will allow access to the grease fitting.

- * Make sure that fittings are accessible through these holes.
- * Make sure Access Plates are closed, with upright edge next to gearbox, before operating, so they don't interfere with grain flow.

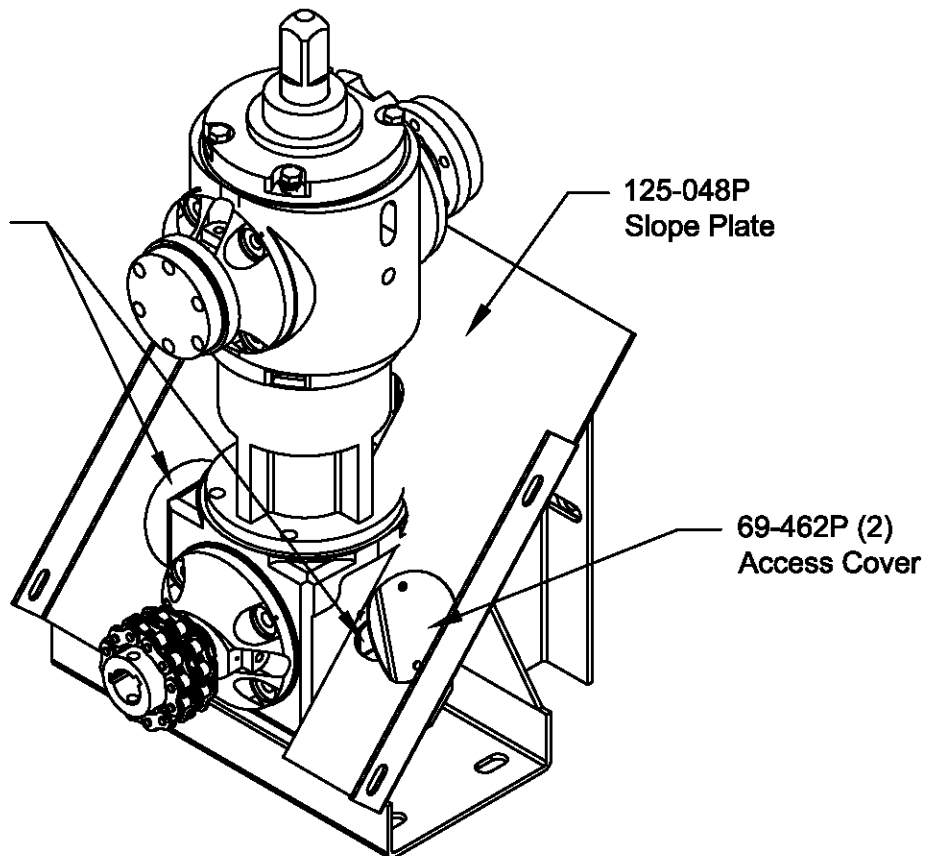

Step 2B: Reinstall Metering Ring (See drawing on following page)

Locate Metering Ring (5-043W) that was removed in Step 4. Remove the bolts and lockwashers from the top of the gearbox. Place the metering ring on top of the gearbox and reinstall the lockwashers and bolts. The two openings on the Metering Ring should be centered over the sweeps when the sweeps are straight out from the gearbox. It may be necessary to twist the ring so the sweeps are in center of the openings. Observe the clearance between the top gearbox bolts and the bottom flange of the gearbox cap. Once the bonnet is installed it may become necessary to adjust this clearance so that the Bonnet Bearing Retainer will clear the gearbox. Also observe the clearance from between the bottom of the metering ring and the top of the basket, at least 1/8" gap should be seen when rotating the gearbox and ring. Bend arms up or down, as required, to get 1/8" - 1/4" gap.

Installing Metering Ring and Bonnet

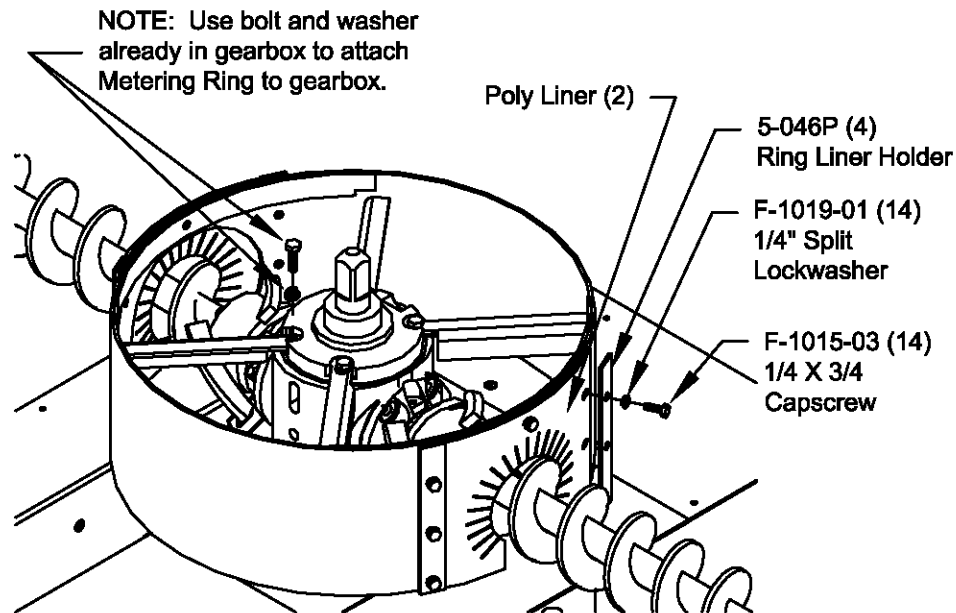

Step 3B: Install Metering Ring Wear Liners

Depending on the size of your sweep, the ring liners should just clear the diameter of the sweep. For regular and hi-capacity sweeps, use 5-056P and for ultra hi-capacity sweeps, use 5-057P. Position the liner over the ring opening and around the sweep. From the hardware sack (5-054A or 5-055A), take one of the 1/4" X 3/4" bolts and 1/4" lockwasher and fasten it in the top center hole of the liner. Locate two (2) of the Liner Holders (5-046P) and place one over the liner on each side of the ring opening. Make sure that the liner holder properly matches the three threaded holes and bolt it in place. Make sure the liner edges are straight, not pushed in or pulled out, before tightening in place. Repeat the procedure for the other sweep.

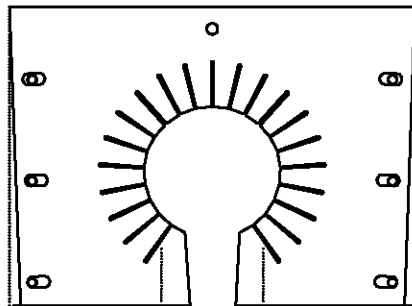

Bottom corners pushed in may cause high center.

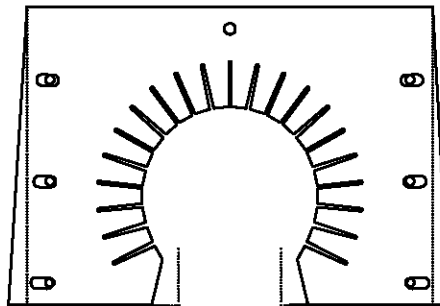

Bottom corners pulled out may cause coning.

Poly Liners

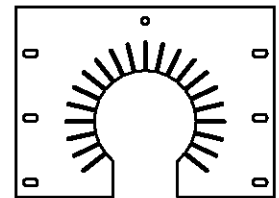

5-056P
Reg / Hi-Cap Poly Liner

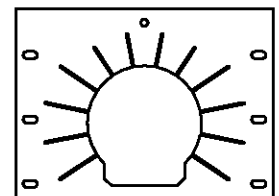

5-057P
Ultra Hi-Cap Poly Liner

Installing Metering Ring and Bonnet

Step 4B: Bonnet Lubrication

Unscrew the threaded rod from the bonnet so that it will not interfere with the top of the gearbox. The threaded rod is only used to assist in removing the bonnet. The jam nut is used so the threaded rod cannot move. Make sure that the bearing is adequately greased. Using the grease zerk on the side of the bearing retainer, pump grease slowly while turning the bearing, this will ensure the bearings are properly lubricated.

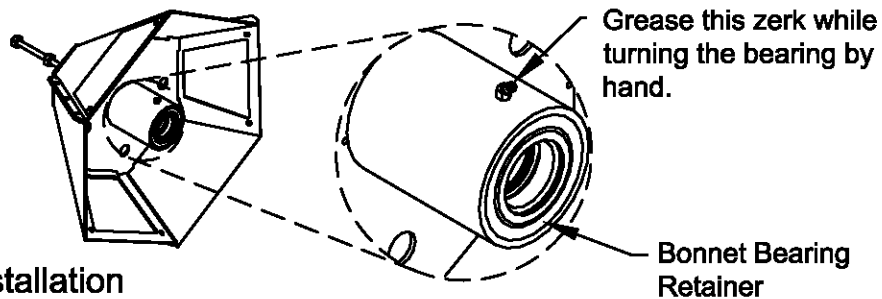

Step 5B: Bonnet Installation

Make sure that the inner race within the bonnet's bearing retainer is free of obstruction and smooth. Place the bonnet over the gearbox and position it on the gearbox cap. Remove an Access Cover (5-052P) to help view and place the bonnet bearing. Using a mallet or sledge, pound the bonnet down evenly over the gearbox. For best results do not pound on the threaded rod, apply force to the top of the hex cap. Place a piece of wood or other similar object on the hex cap of the bonnet to prevent denting or marring.

Once the bonnet is forced down, it should spin freely. If any interference is experienced, it is likely that the four bolts on the top of the gearbox are rubbing against the bearing retainer. If this is the case, the bonnet will have to be removed and the problem fixed.

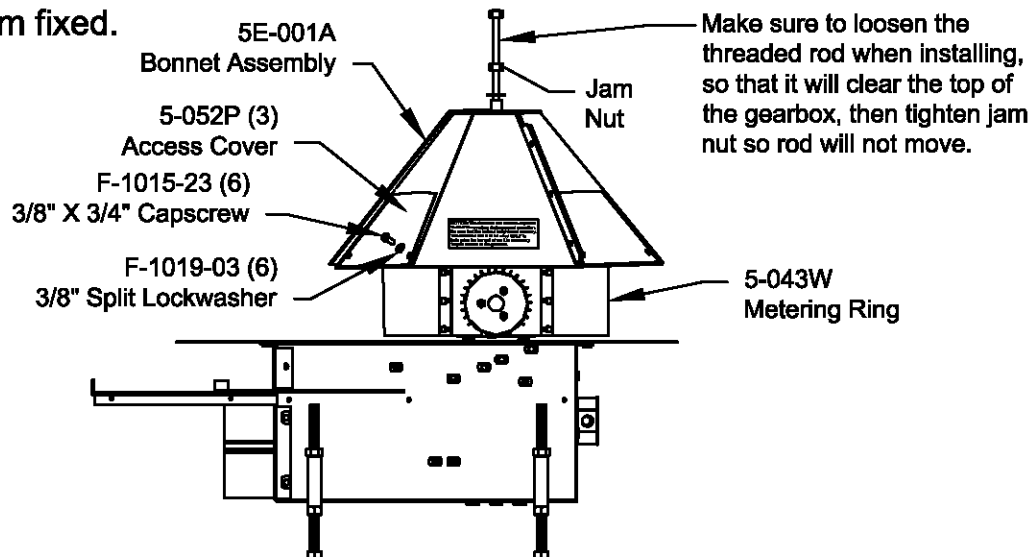

Installing Metering Ring and Bonnet

Step 6B: Removing the Bonnet (if required)

To remove the bonnet, loosen the jam nut and screw the threaded rod down so that it hits the top of the gearbox. Slowly screw down the rod until the bonnet becomes loose. Lift the bonnet off the gearbox and turn upside down before setting on the floor. This will ensure that no dirt or grain enters the bonnet's bearing retainer. At this point the split ring washers can be replaced with 3/8" internal star washers (F-1295), which are thinner. If more clearance is needed, replace the four bolts with 1-1/4" X 3/8" button head bolts. Return the bonnet to the top of the gearbox, making sure to unscrew the threaded rod first.

Step 7B: Lock Threaded Rod

After the bonnet is installed, position the threaded rod so that it sufficiently clears the gearbox. Lock the rod in place with the jam nut.

Step 8B: Level Dry Option

On units with a Level Dry, place the center vertical tube and Level-Dry over the bonnet. Consult your Level Dry Installation Manual.

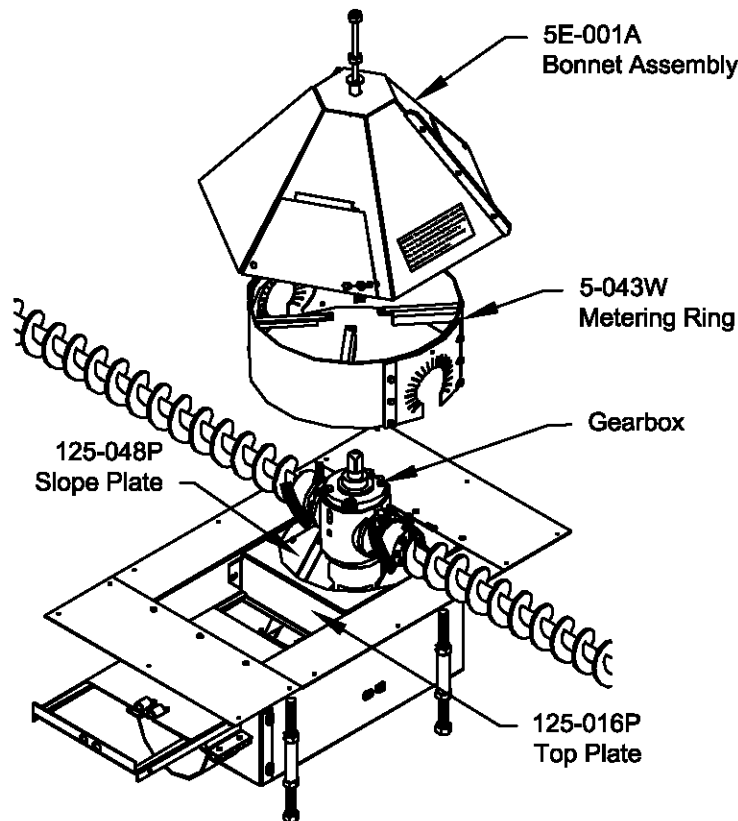

Installing Motor Mount and Accessories

Step 1C: Transition Openings

There are two outlets on the transition. Both outlets may be used together or one can be blocked off using a flange door (672-059P). The flange door comes pre-assembled to the side discharge of the transition. It can be removed and placed elsewhere if needed. If using a Jumpster, clamp the Jumpster onto the side discharge opening, following the instructions provided with the Jumpster. If the side discharge is not used, the flange door will block off the opening. The down discharge opening comes pre-assembled with the Safety Grill Outlet (672-068W).

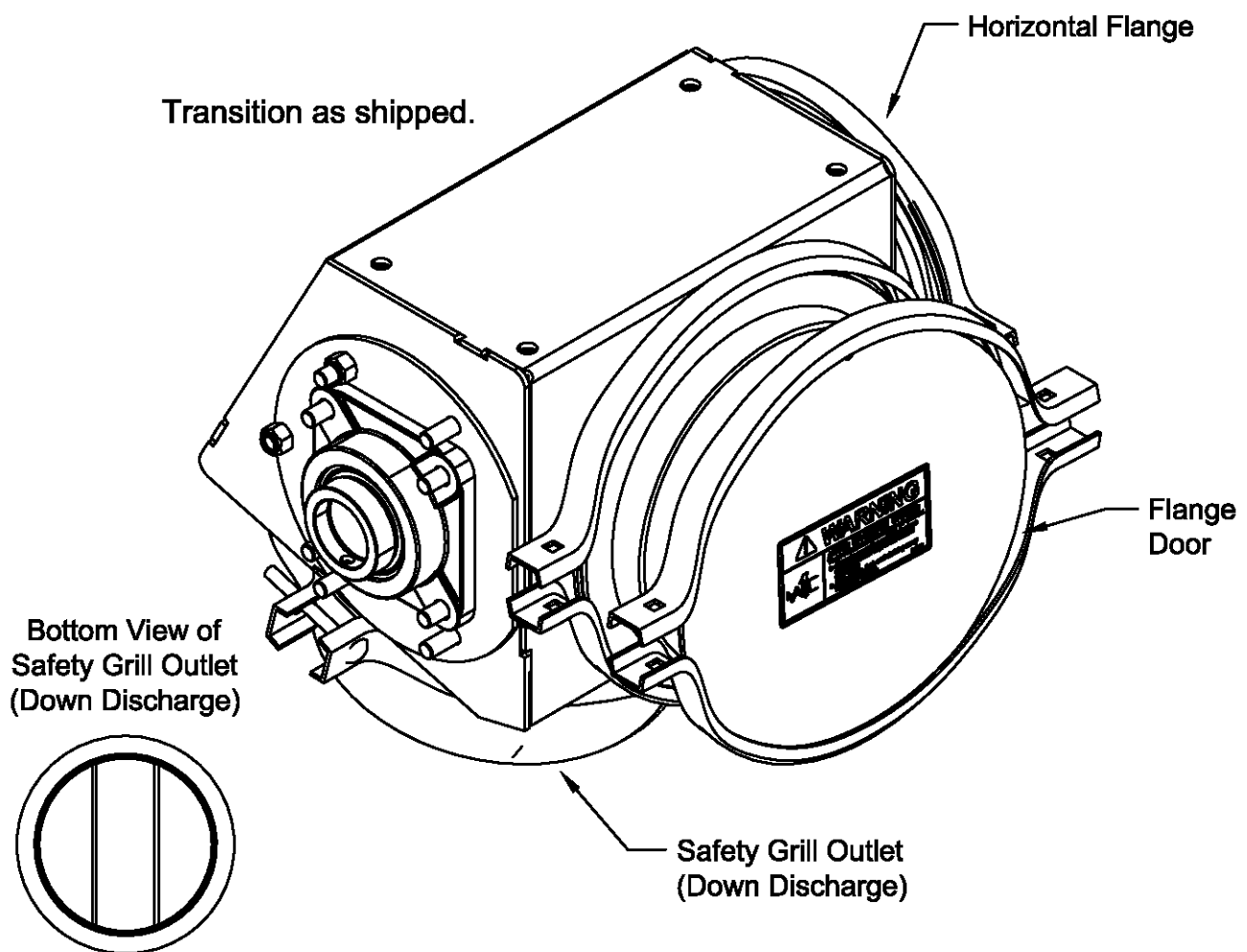

WARNING

NEVER OPERATE UNLESS THE DISCHARGE OUTLETS ARE SHIELDED BY THE SAFETY GRILL OUTLET, THE JUMPSTER, OR THE FLANGE DOOR.

Installing Motor Mount and Accessories

Step 2C: Installing Motor Mount

Install the Bottom Motor Mount to the transition using (4) 3/8 X 1-1/4 bolts, (4) 3/8" lock washers, and (4) 3/8" flat washers, located in the Dri-Flo Motor Mount hardware sack (672-036A). Install the Dri-Flo Idler Mount to the under side of the Bottom Motor Mount using (4) 3/8 X 1-1/4" bolts, (8) 3/8" flat washers, and (4) 3/8" lock nuts located in the Dri-Flo Idler Mount hardware sack (672-078A). NOTE: Do not install the Idler Pulley until after the inner belt shield is in place. Install the motor adjuster nut and motor adjuster bolt, with other hardware, in order, on the Top Motor Mount. (See drawing below for more details.) Bolt the Top Motor Mount in place with (2) 1/2 X 1-1/4" bolts, (2) 1/2" lock washers, and (2) 1/2" flat washers, located in the Dri-Flo Motor Mount hardware sack (672-036A). NOTE: Extra washers are provided for shims in the case of excessive space between the top and bottom motor mounts. Tighten bolts down until there is enough pressure to keep the top from falling on its own. Locate the 672E-001A Belt Shield Kit. Install the Inner Belt Shield (672-040W) by removing the nuts that hold the bearing plate in place. Set the Inner Belt Shield in place and use the same nuts to secure the Inner Belt Shield and bearing plate. Use Spacer Plates (672-037P) only if more clearance is needed. Narrow 1/2" washers are in the 225-079A, Belt Shield Sack.

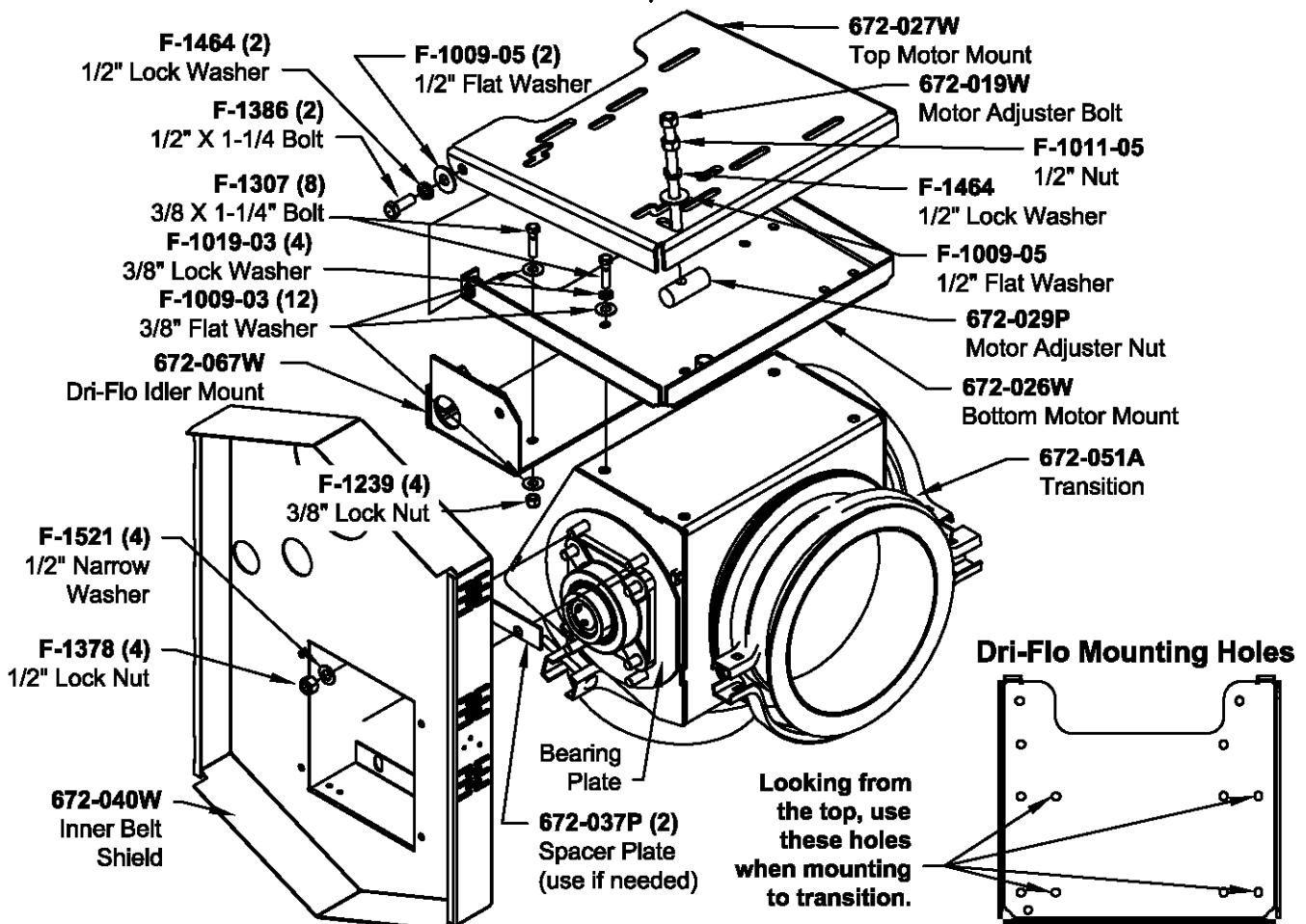

Installing Motor Mount and Accessories

Step 3C: Installing Idler Pulley and Side Shields

Check to be sure that the internal bearing spacer is aligned with the roller bearings. Slide the 1" Washer onto the Idler Pulley Shaft. Press the Idler Pulley Shaft through the bearing assembly and slide the other 1" Washer onto the Idler Pulley Shaft. Bolt the pulley assembly to the Idler Mount using a 1/2 X 1-1/4 bolt, 1/2" lock washer, and 1/2" flat washer, applying loctite to the threads. Install Side Shields with the small flange pointed inward toward the bearing using hardware provided. Put the bolt, lockwasher, and flat washer on the inside of the Inner Belt shield.

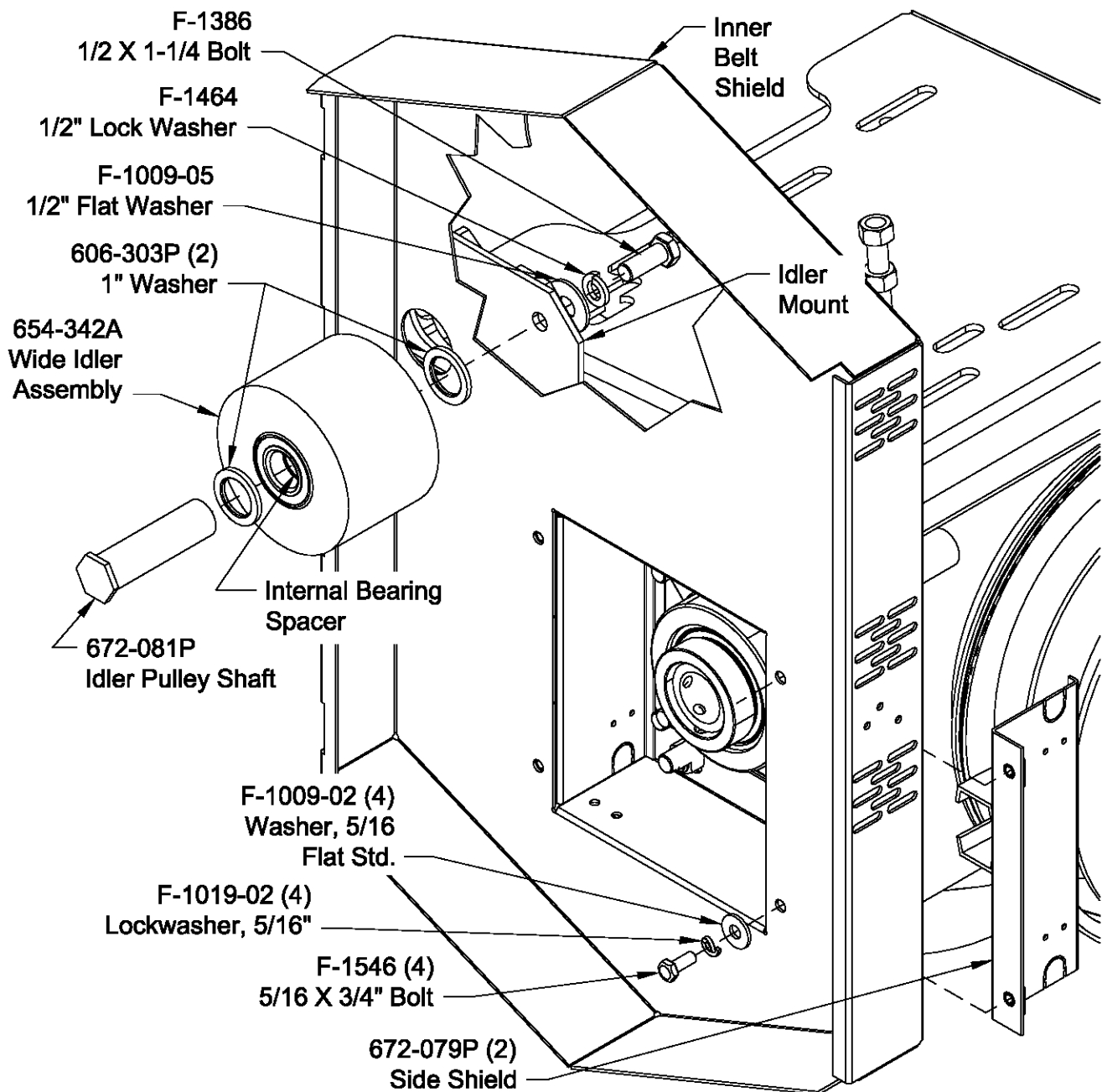

Installing Motor Mount and Accessories

Step 4C:

Attach latch draw to belt shield back using three holes on the side.

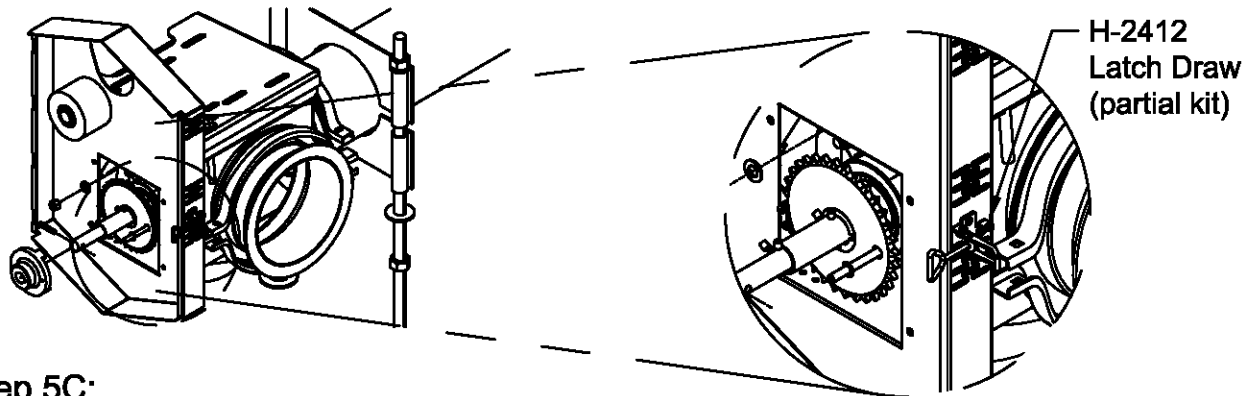

Step 5C:

Remove the roll pin and 3-jaw clutch from the 1" drive shaft of the horizontal unloader. Slide the 15" 3-groove pulley onto the 1-3/8" flight weldment tubing of the horizontal unloader until it is almost touching the 32 tooth sprocket. Make sure the 3 notches of the 15" pulley are facing away from the 32 tooth sprocket. The front bearing should be about flush with the end of the 1-3/8" tubing. Tighten all four bearing set screws (2 front and 2 rear) of the 15" pulley. This attaches the 15" pulley to the unloader flight weldment. Make sure the clutch pin of the 15" pulley will engage into the 32 tooth sprocket.

Check that the 15" 3-groove pulley clears the inner belt shield. If it doesn't, loosen the set screws in the 4 hole bearing and pull more of the 1-3/8" flite weldment tube toward the outside of the bin. If this is done, it may be necessary to re-adjust the 8" tube in the basket. (See page 16, Step 11.)

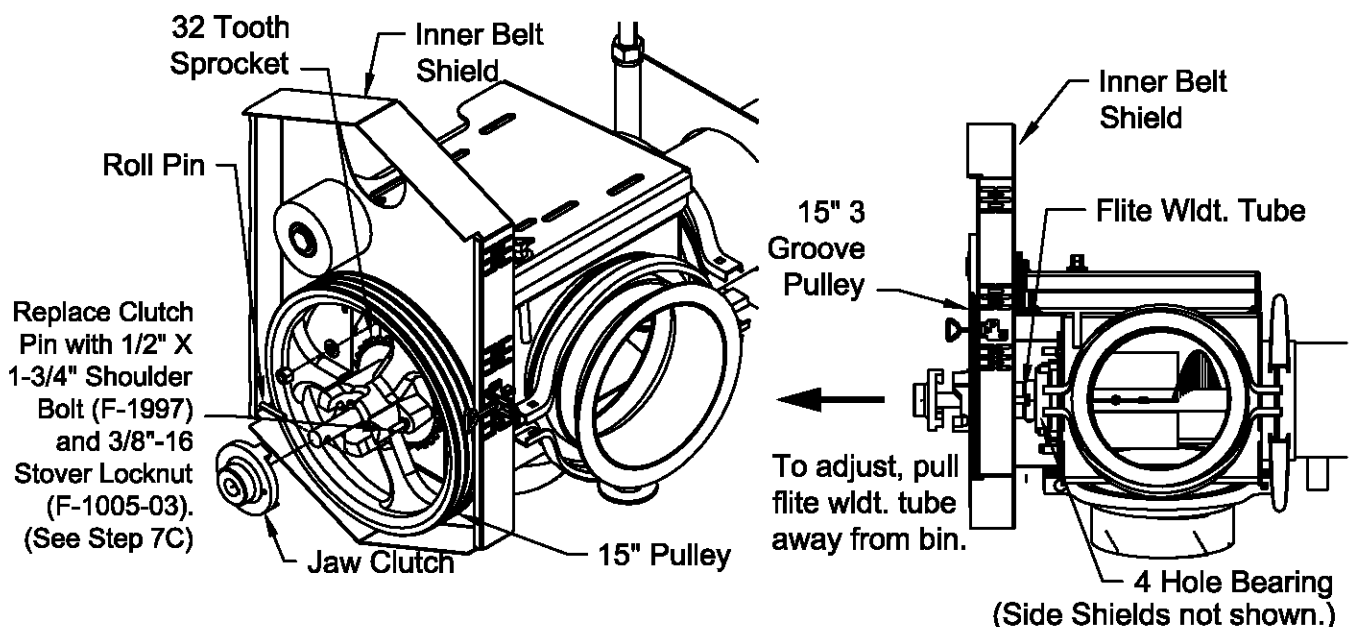

Installing Motor Mount and Accessories

Step 6C: Installing Motor

NOTE: Pulley alignment is critical. Pulleys must be aligned as close as possible. Pulley must be set in a location that allows belts to run in the center of the Idler Pulley.

Use a 4X4 to block up the Top Motor Mount. Set the motor onto the Idler Mount as far forward as possible to align with the 15" Pulley. Bolt the motor to the Top Motor Mount using (4) 3/8 X 1-1/4 bolts, (8) 3/8" flat washers, and (4) 3/8 lock nuts located in the Dri-Flo Motor Mount hardware sack (672-036A).

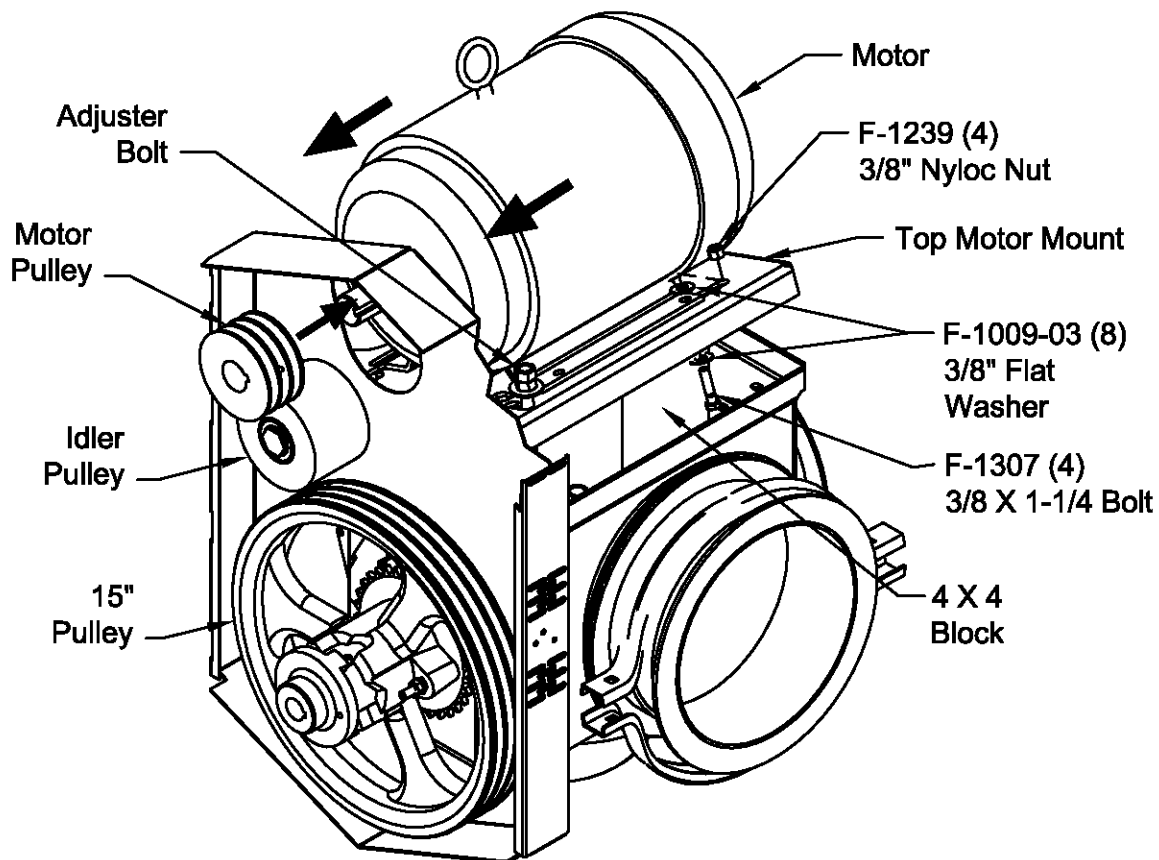

Slide on the Motor Pulley to check the location with the 15" Pulley and the Idler Pulley. Install the AX-60 belts (D-3003-12) and check again the alignment of the belts. Tighten the set screw in the motor pulley. To adjust the belt tension, tighten or loosen the adjuster bolt in the Top Motor Mount.

Installing Motor Mount and Accessories

Step 7C:

Replace the clutch pin with a 1/2" X 1-3/4" Hex Head Shoulder Bolt (F-1997) and a 3/8"-16 Stover Locknut (F-1005-03), so the unloader is always engaged.

To install the Shoulder Bolt without disassembling the 15" Pulley, rotate 15" Pulley and Sprocket so that the holes are lined up in the 0° location (See Figure 2). Remove snap ring and slide clutch pin out of the pulley (See Figure 1). It may be necessary to grind a flat spot on the front of the pulley for the locknut. Feed the Shoulder Bolt through the backside of the sprocket, with the threads toward the front (See Figure 3). Finger tighten the Stover Locknut onto the Shoulder Bolt. Rotate the 15" Pulley and sprocket up about 45° and tighten the bolt and locknut with a 3/4" wrench and 9/16" wrench.

Figure 1

Remove snap ring to take out clutch pin.

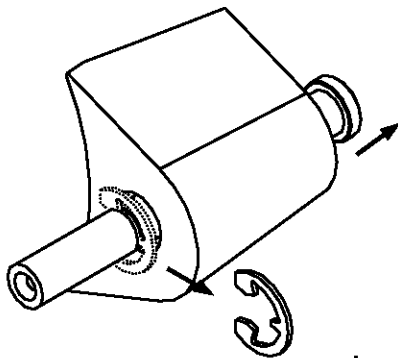

Figure 2

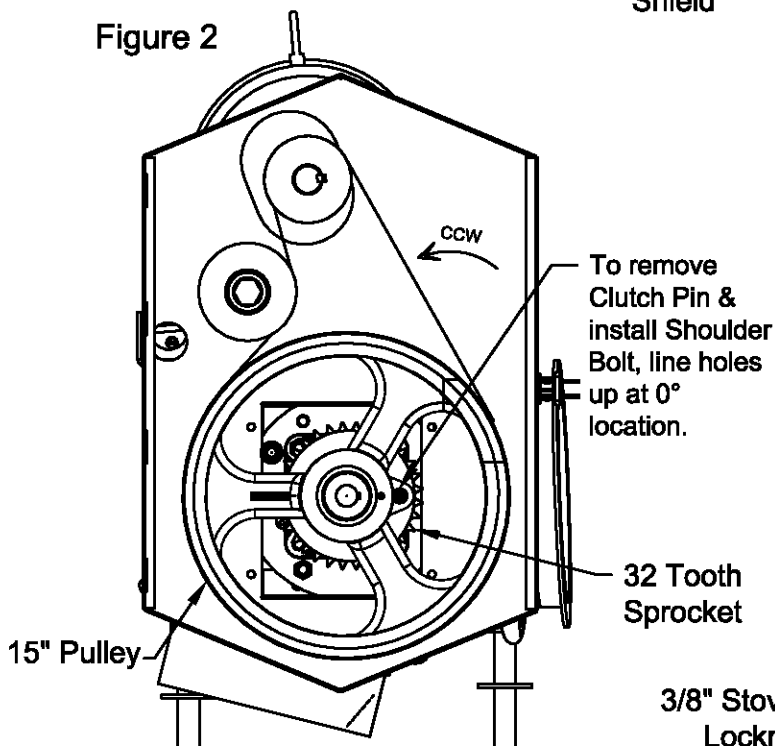
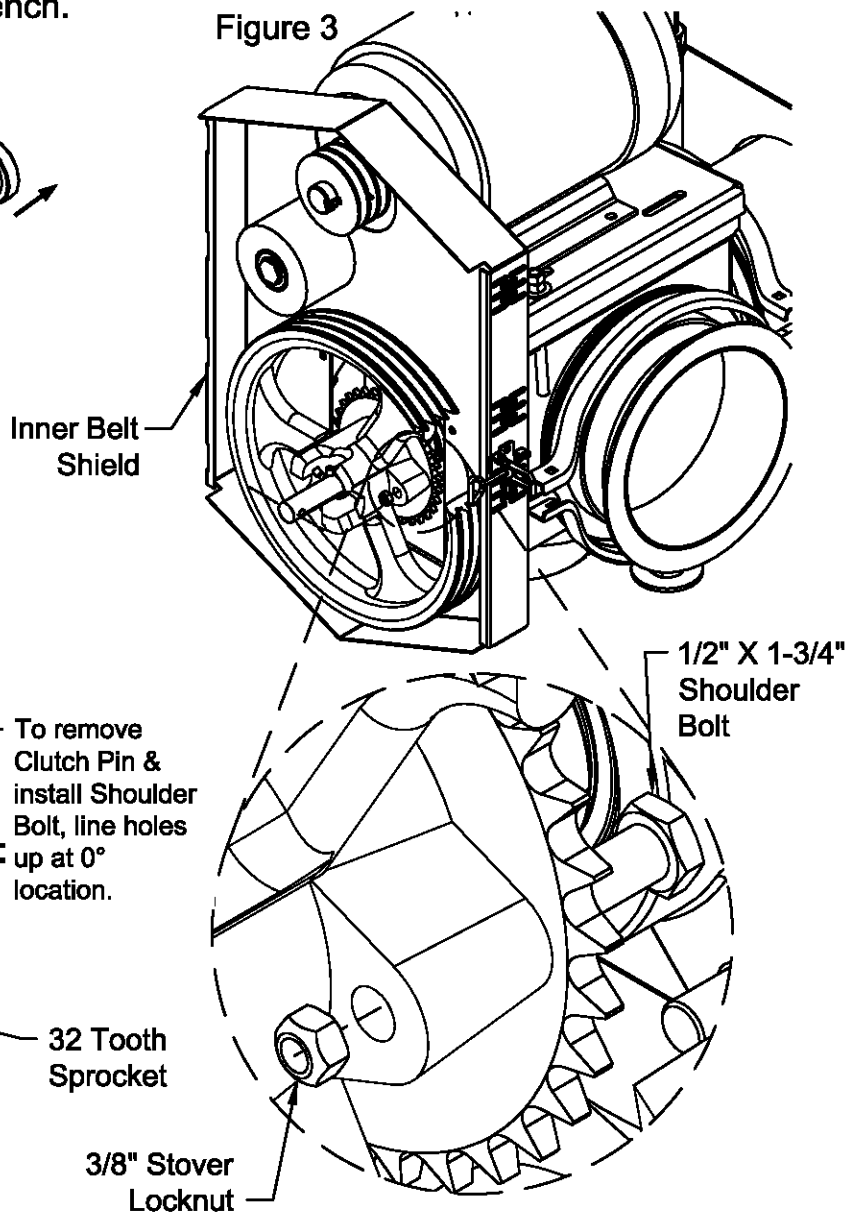

Figure 3



Installing Motor Mount and Accessories

Step 8C:

Re-install the 3-jaw clutch and roll pin. Check for full engagement and disengagement.

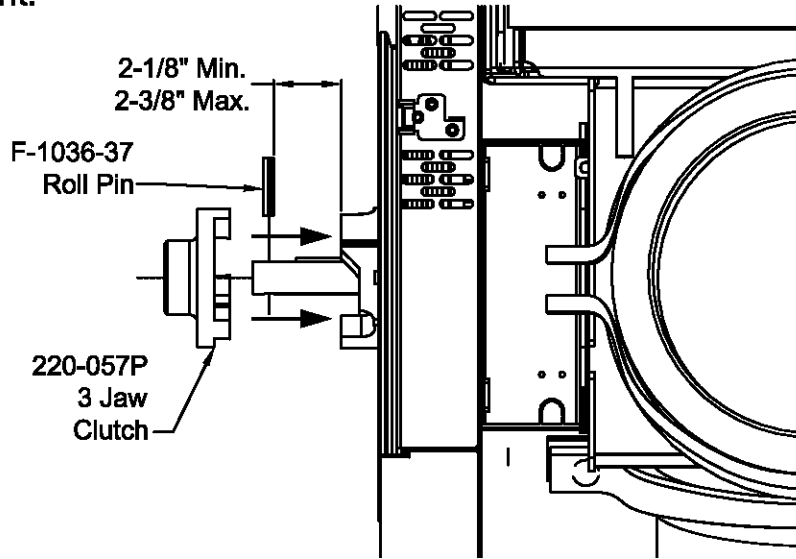

Step 9C:

Attach latch striker from H-2412 kit to belt shield cover (225-080A) into bottom holes, using hardware provided with kit. Install belt shield cover onto inner belt shield, as shown.

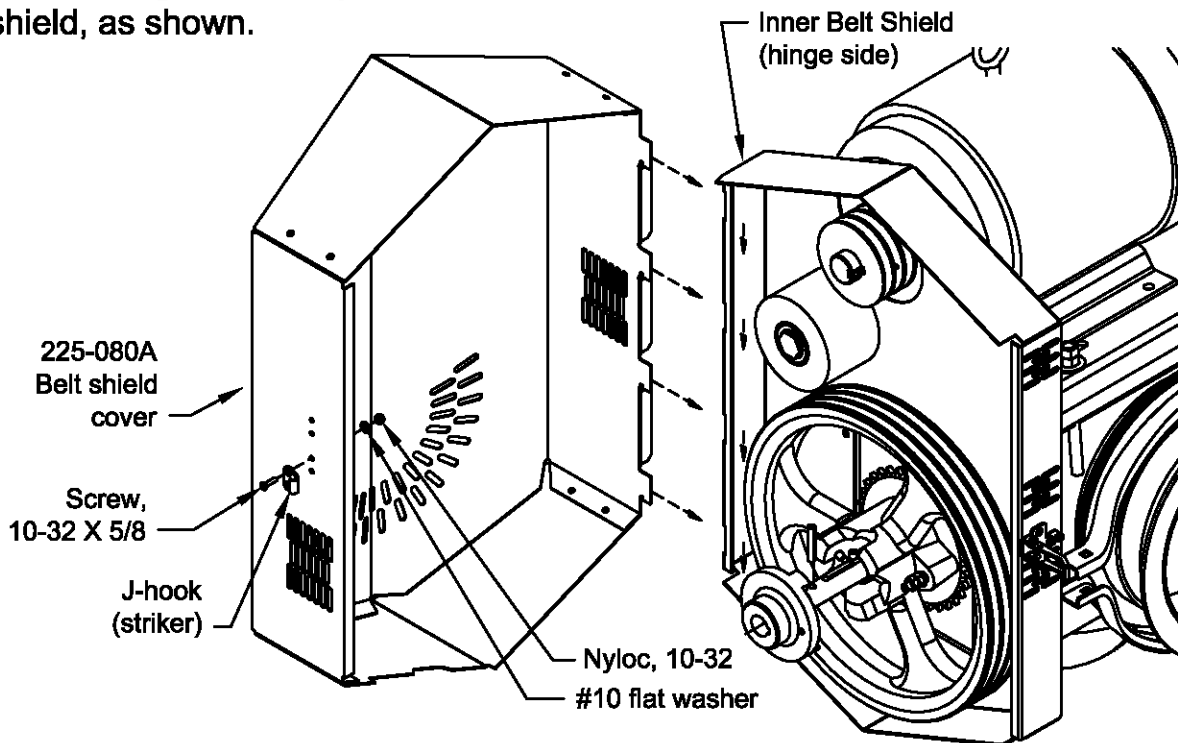

Align door hinge tabs to the 4 slots in back weldment. Hold door open at 45° and insert. Let weight of door go down to lock hinges in position.

Installing Safety Decals and Locks

Before applying decals, make sure the mounting surfaces are clean (not oily) and dry.

P-10811 - Field Installed

1.) ON MAIN POWER DISCONNECT SWITCH BOX

Put it only on the disconnect that shuts power off to the complete drying system (every motor, fan, and burner). Don't put it on any other disconnect.



"CAUTION" Decal
Shivvers# P-10811

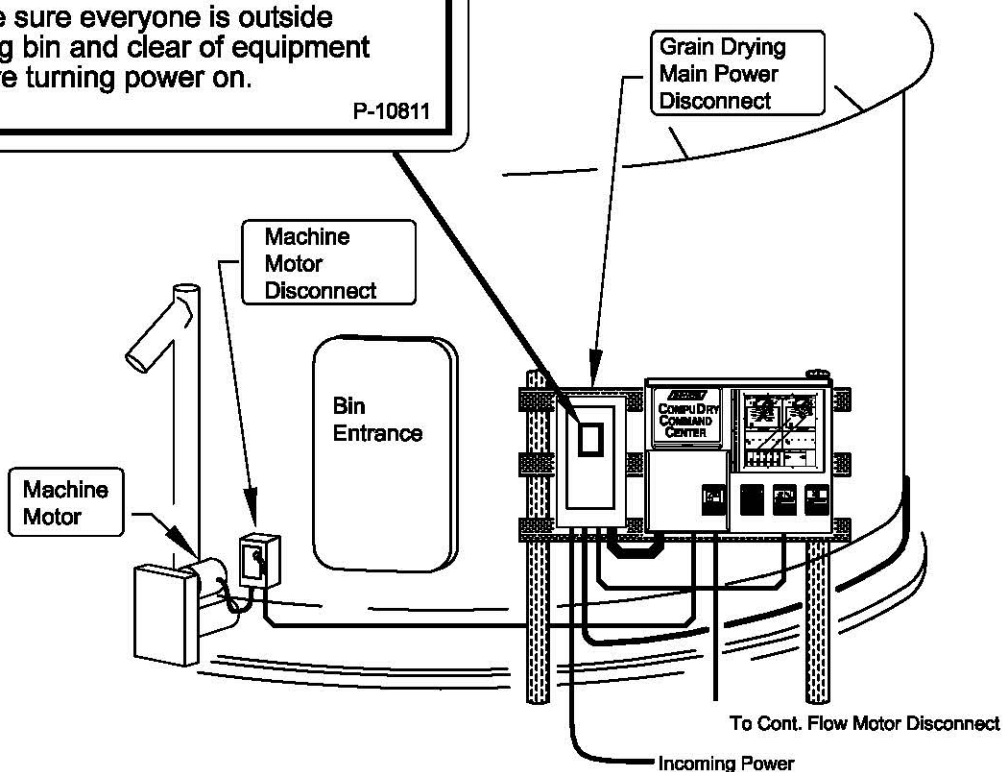

Installing Safety Decals and Locks

P-12184 - Field Installed

A Machine (Circu-Lator or Dri-Flo) Motor disconnect switch must be located adjacent to the bin entrance door. It must be of sufficient capacity to safely switch the Machine Motor, usually 10 or 15 Hp. This switch must also have the capability of being locked into the OFF position.

Make sure the safety decal P-12184 is applied on or near the machine motor disconnect.

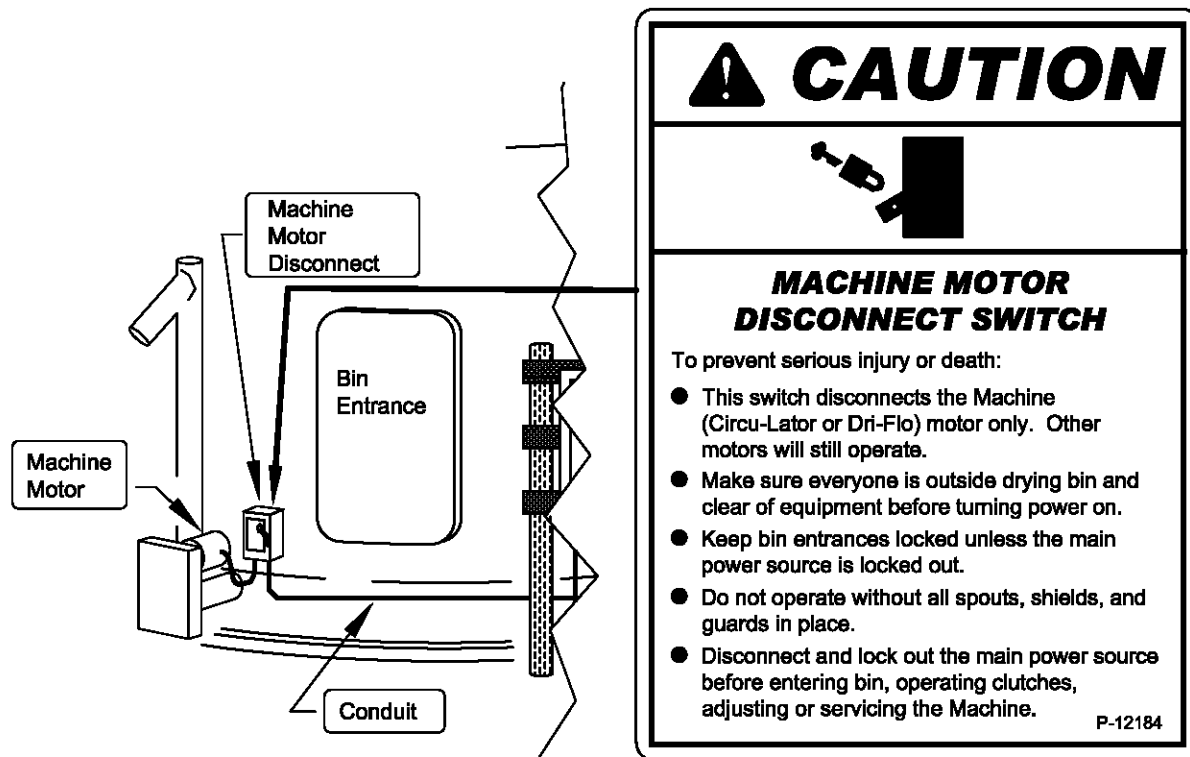

"CAUTION" Decal
Shivvers# P-12184

Installing Safety Decals and Locks

P-11035 - Field Installed

- 1.) ON ALL CONTROL BOXES THAT CONTROL TAPERED SWEEP AUGERS (Circuitrol, Comp-U-Dry, etc.) (Factory Installed).
- 2.) OUTSIDE OF OUTER BIN DOOR ENTRANCE
- 3.) OUTSIDE OF INNER BIN DOOR ENTRANCE
- 4.) NEAR MANHOLE ENTRANCE

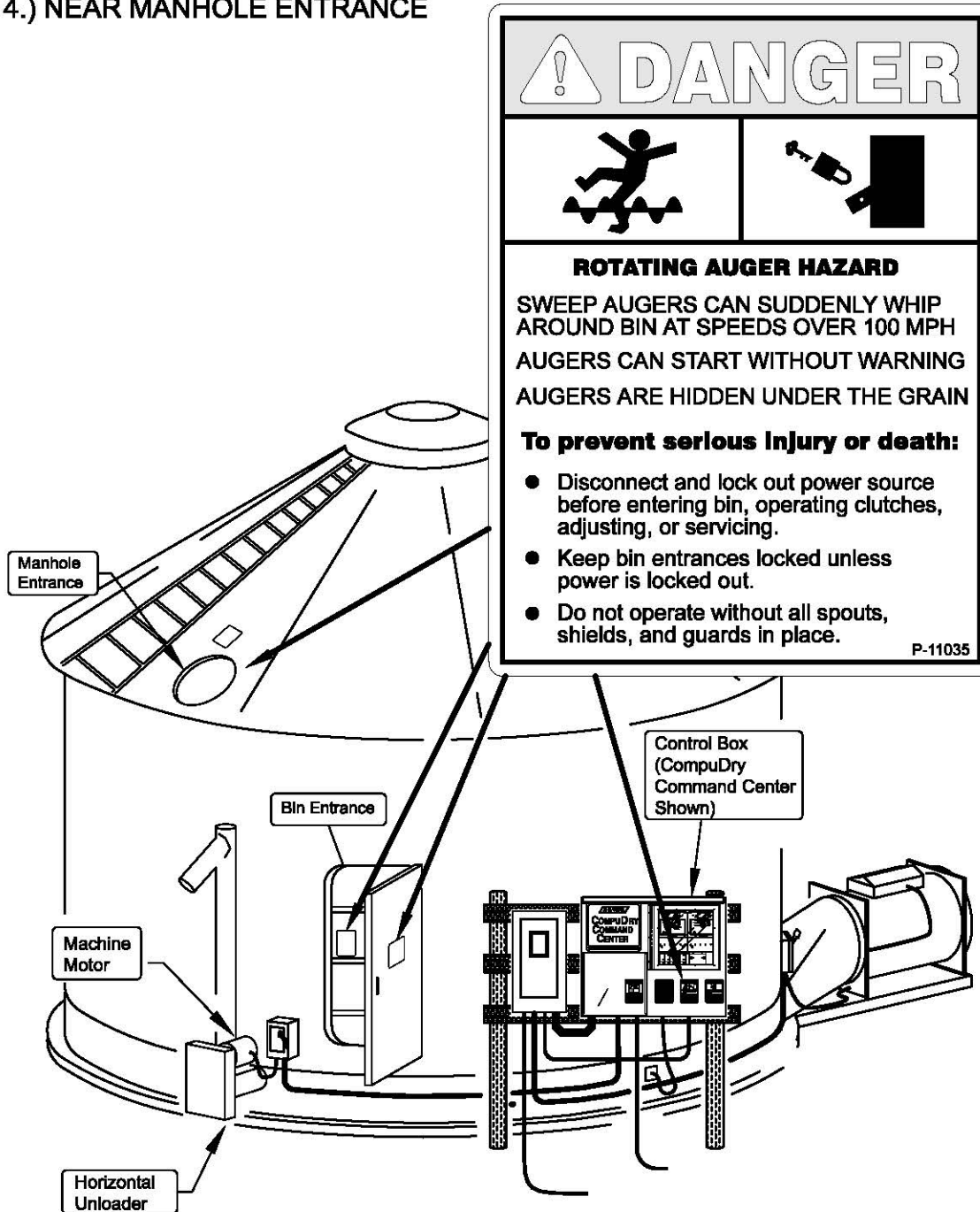

Installing Safety Decals and Locks

P-10125 - Field Installed

- 1.) INSIDE OF OUTER BIN DOOR ENTRANCE ON ALL BINS
- 2.) NEAR MANHOLE ENTRANCE ON ALL BINS

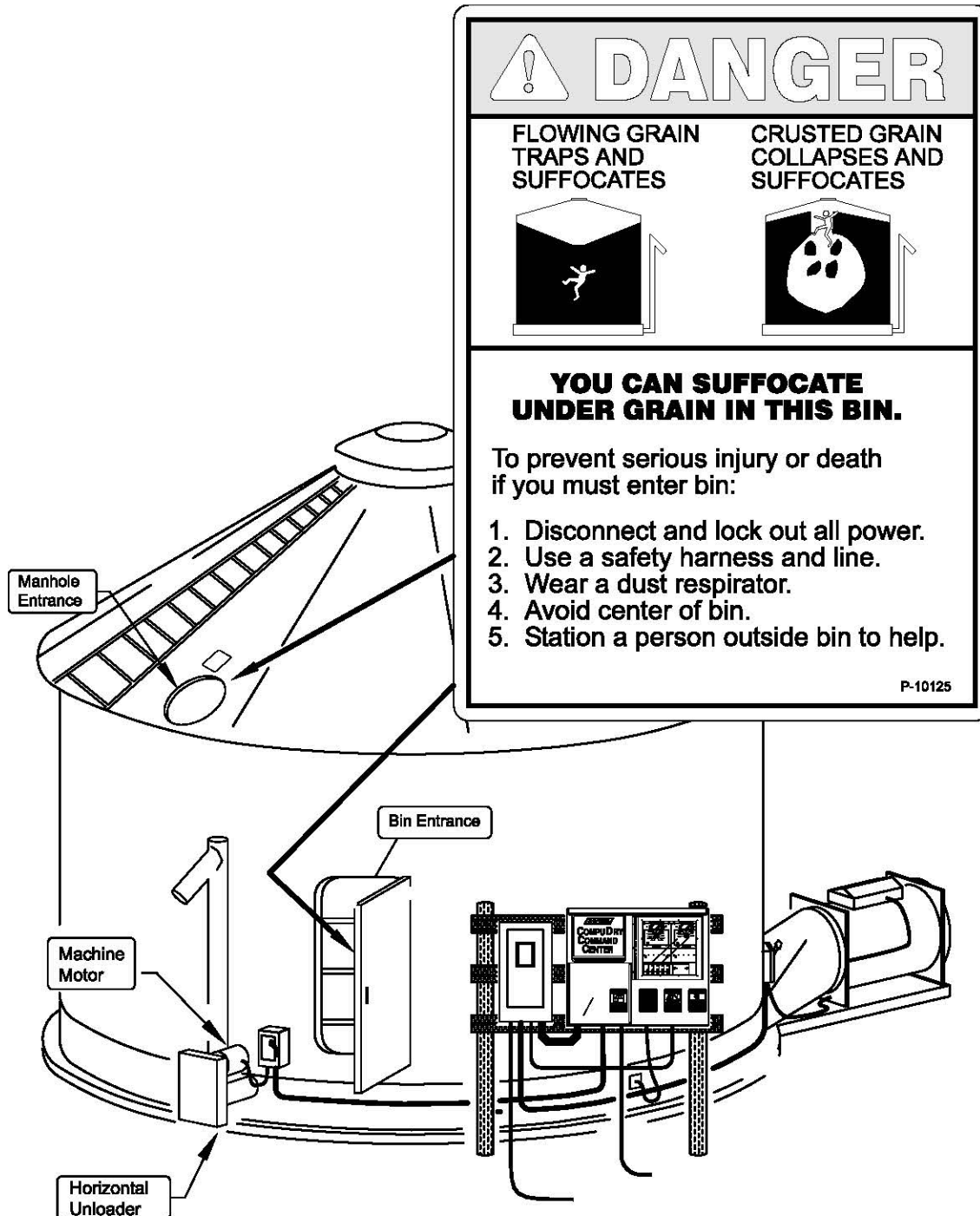

Installing Safety Decals and Locks

Two 632-191A (Safety Lock Kits) are provided with each Shivers dryer. This kit includes an H-2055 Padlock, P-11158 Self Laminating Lockout Decal, and hardware which will allow locking of any bin entrance point.

Make sure a grain drying main disconnect box is installed and that this padlock works on it. If it doesn't, find one that will or contact Shivers Incorporated for assistance. Leave the power locked off.

If the dryer bin is not equipped with a lockable entry door in good condition, attach one end of the cable assembly to the bin side wall. Use an existing bolt, or use the hardware provided. Attach the staple plate to the bin entrance door within reach of the opposite end of the cable assembly. Use the hardware provided, or weld the staple plate securely to the door.

Install a safety lock kit on the manhole cover also. If there are more than two entrances on the bin, order additional Safety Lock Kits. Try the locks and make sure entrance to the bin is denied.

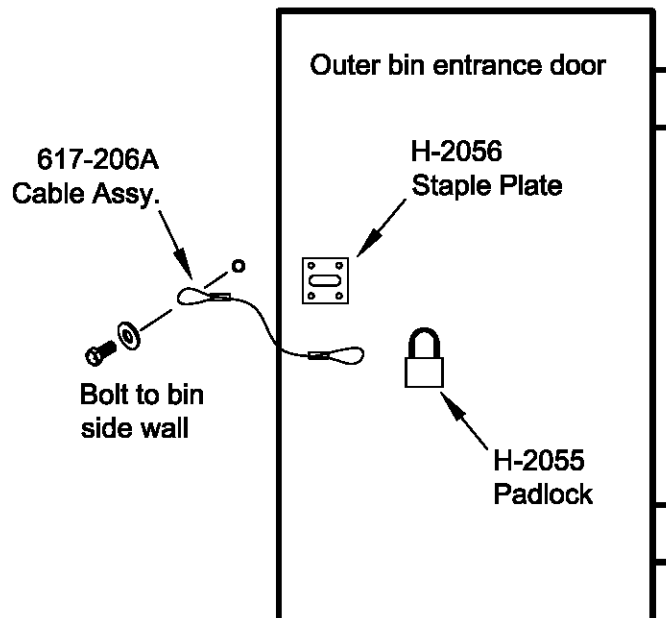

Installing Safety Decals and Locks

P-11158 - Field Installed

Write your name on the decal. Cover the printing with the clear laminate, then apply the decal to the padlock. These locks can then be used to lock out power sources when working on the drying equipment. Keep the bin entrances locked when operating the equipment to prevent unauthorized access to potential dangers. The locks will also remind you to disconnect and lock out power sources before entering the bin.

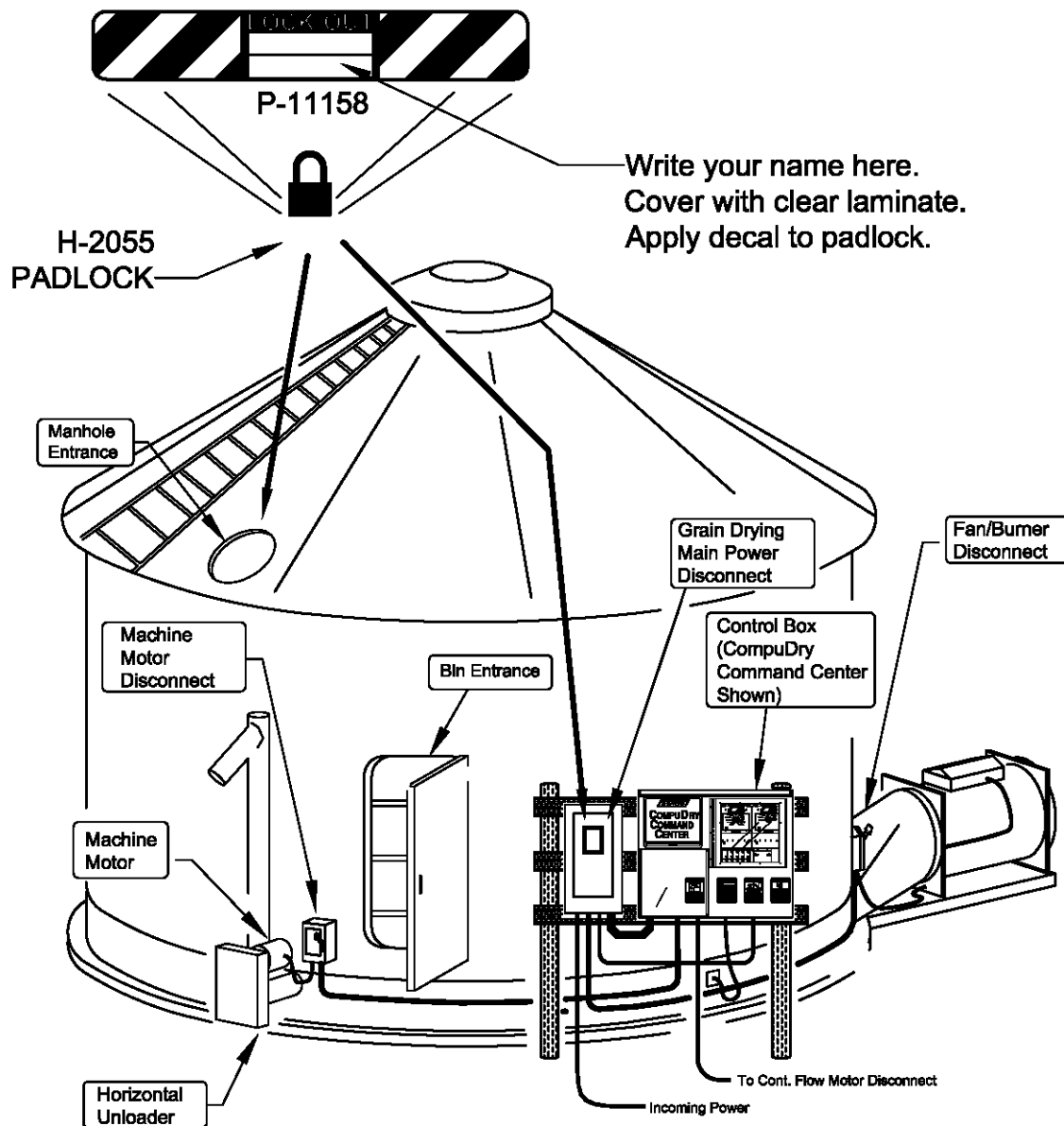

DRI-FLO Installation Final Check

- 1□ Check that all joints are level and solid, without cracks, in the tapered sweep wheel track, and that the track is pop riveted, not screwed, down.
- 2□ Make certain the tapered sweep wheel(s) do not hit pop rivets in the track.
- 3□ Make sure the tapered sweep augers have "flex" in the coupling by lifting the outer end in several locations around the bin.
- 4□ Make sure gearbox is square with the floor. Use gearbox laser kit.
- 5□ Check that the chain coupler master link is installed correctly.
- 6□ Make sure there is 1/8 - 1/4" gap between the horizontal flight weldment tube and the sprocket on 1" drive shaft where O-ring is located, inside the basket.
- 7□ Make sure the Bonnet and Metering Ring are free to rotate without catching.
- 8□ Make sure the correct ring liners are installed and are centered on the tapered sweep augers.
- 9□ Make sure the tapered sweep couplers are greased with high temperature grease.
- 10□ Make sure the unloading pin has been replaced with the shoulder bolt.
- 11□ Make sure the 3-jaw clutch will operate correctly.
- 12□ Check belt alignment and tension. Make sure belts don't try to roll over.
- 13□ Check slide gates for proper operation and leave them in the closed position.
- 14□ Make sure all Safety Decals are in place as shown in P-10001 Operator's Safety Manual. Make sure all guards are in place.
- 15□ Make sure the Safety Lock Kits (632-101A) are installed as shown in this manual and P-10001 Operator's Safety Manual, and P-11175 Instructions. Either the bin entrances or the power should be locked off.
- 16□ Make sure the operator has the Operator's Safety Manual, Operating manuals for each piece of equipment installed, and Safety Lock keys. Make sure they understand how to operate each piece of equipment safely.