

# SHIVERS

## DELUX CIRCU-TROL PARTS MANUAL

P-11038

Delux Circu-trol Panel, 1 Phase, 220V, 5-5 HP  
CTDL220V1P55

Basic Mounting Plate Assy, 295A-116A

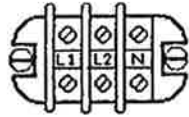

E-5054  
Terminal Bd.  
3 Circuit

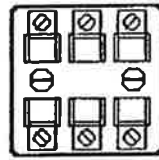

E-5001-01  
Fuse Block  
3 Circuit

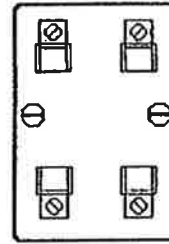

E-5001-02  
Fuse Block  
2 Circuit

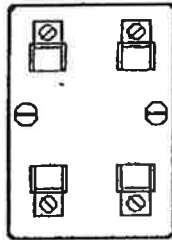

E-5001-02  
Fuse Block  
2 Circuit

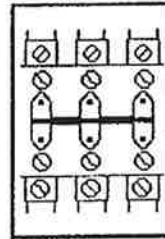

E-6511

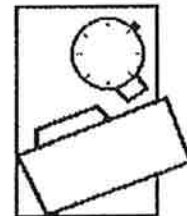

423-378-001A

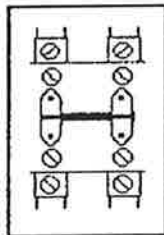

E-6511

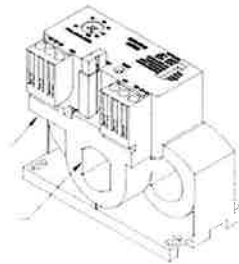

E-6517  
10-40 Amps

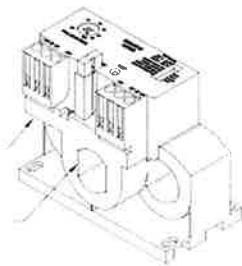

E-6517  
10-40 Amps

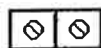

E-5008-01  
Ground Lug

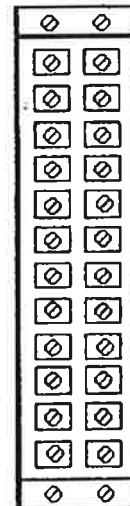

E-5366  
Terminal  
Bd.  
12 Pt.

Delux Circu-trol Panel, 3 Phase, 220V, 10-10 HP  
CTDL220V3P1010

Basic Mounting Plate Assy. 295B-117A

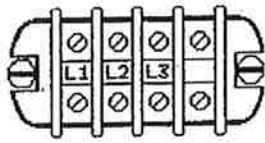

E-5055  
Terminal  
4 Circuit

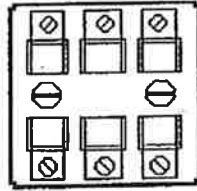

E-5001-01  
Fuse Block  
3 Circuit, 30A

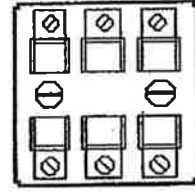

E-5001-01  
Fuse Block  
3 Circuit, 30A

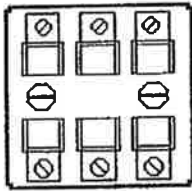

E-5001-01  
Fuse Block  
3 Circuit, 30A

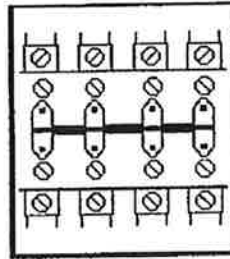

E-6511

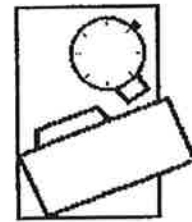

423-378-001A

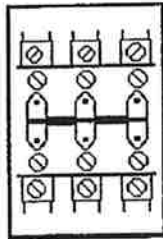

E-6511

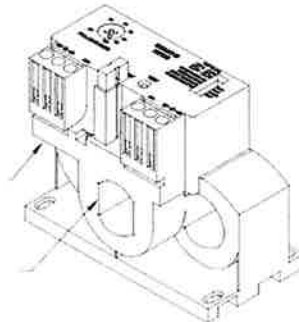

E-6517  
10-40 Amps

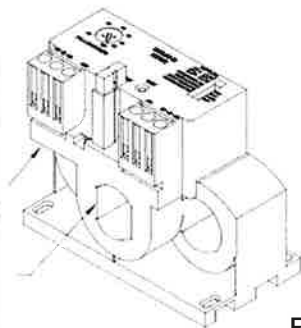

E-6517  
10-40 Amps

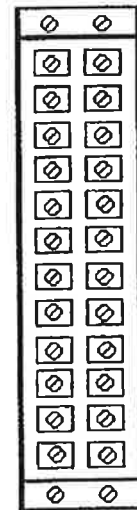

E-5366  
12 Pt.  
Terminal  
Bd.

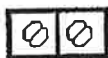

E-5008-01  
Ground  
Lug

Delux Circu-trol Panel, 1 Phase, 220V, 10-5 HP  
CTDL220V1P105

Basic Mounting Plate Assy, 295C-118A

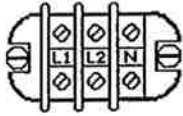

E-5054  
Terminal Bd.  
3 Circuit

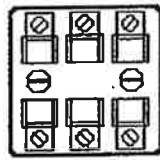

E-5001-01  
Fuse Block  
3 Circuit, 30A

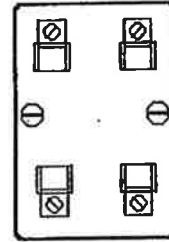

E-5001-02  
Fuse Block  
2 Circuit, 60A

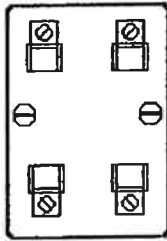

E-5001-02  
Fuse Block  
2 Circuit, 60A

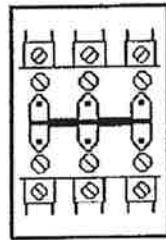

E-6511

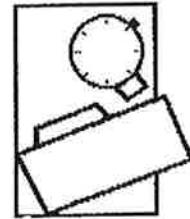

423-378-001A

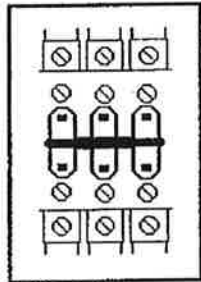

E-6513

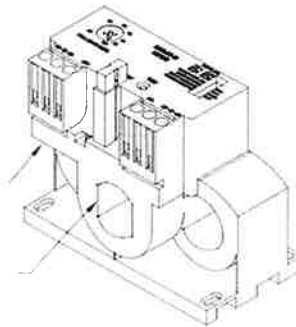

E-6517  
10-40 Amps

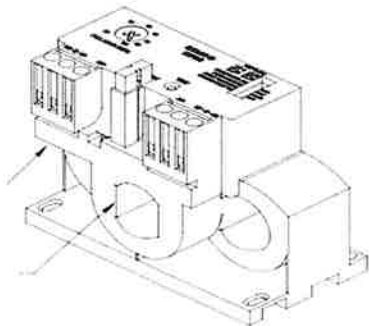

E-6518  
25-100 Amps



E-5008-01  
Ground Lug

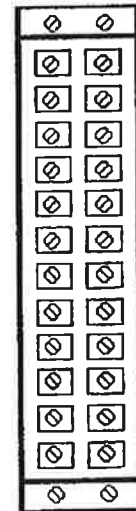

E-5366  
Terminal  
Bd.  
12 PT.

Delux Circu-trol Panel, 3 Phase, 440V, 10-10 HP  
CTDL440V3P1010

Basic Mounting Plate Assy. 295D-119A

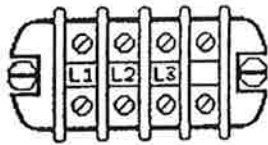

E-5055  
Terminal  
4 Circuit

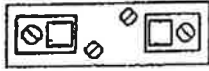

E-5001-03  
Fuse Block  
1 Circ. 30A

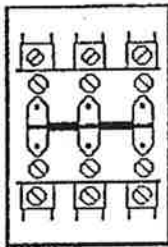

E-6511

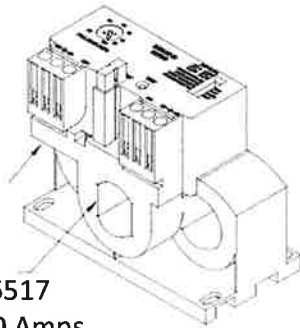

E-6517  
10-40 Amps

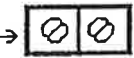

E-5008-01  
Ground  
Lug

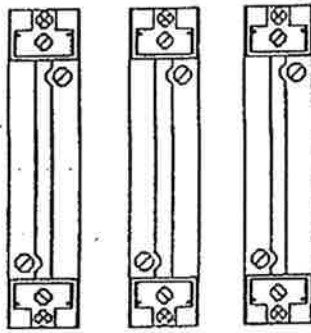

E-5142 (6)  
Fuse Holder  
600V 30A

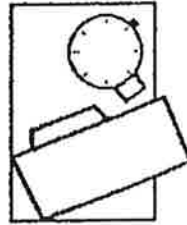

423-378-001A

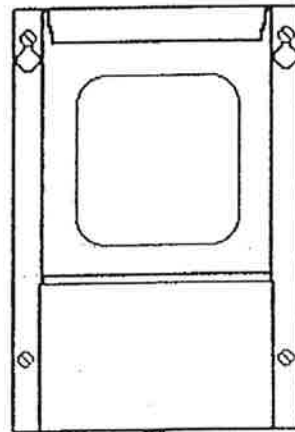

E-5222

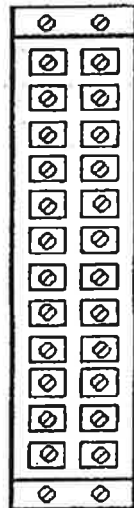

E-5366  
12 Pt.  
Terminal  
Bd.

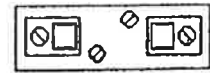

E-5001-03  
Fuse Block  
1 Circ. 30A

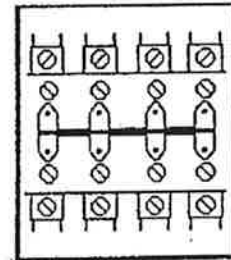
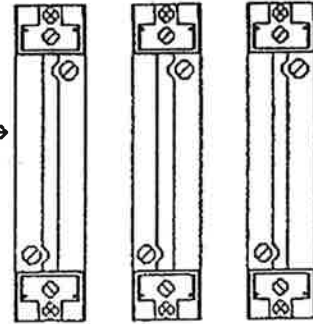

E-6511

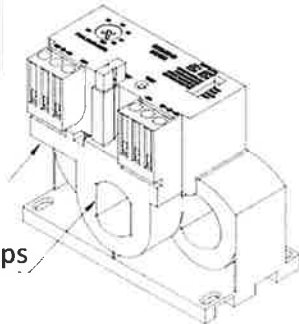

E-6517  
10-40 Amps

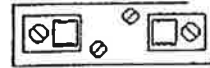

E-5001-03  
Fuse Block  
1 Circ. 30A

Delux Circu-tron Panel, 1 Phase, 220V, 1010HP  
CTDL220V1P1010

Basic Mounting Plate Assy, 295K-247A

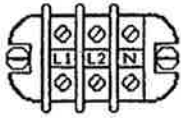

E-5054  
Terminal Bd.  
3 Circuit

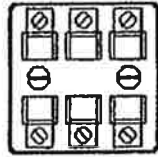

E-5001-01  
Fuse Block  
3 Circuit, 30A

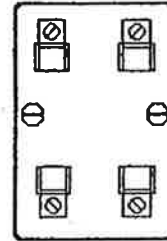

E-5001-02  
Fuse Block  
2 Circuit, 60A

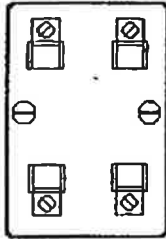

E-5001-02  
Fuse Block  
2 Circuit, 60A

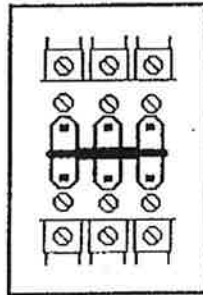

E-6513

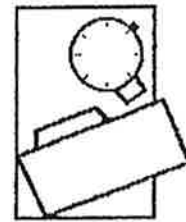

423-378-001A

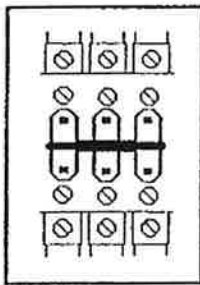

E-6513

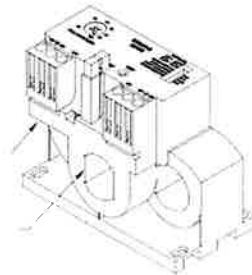

E-6518  
25-100 Amps

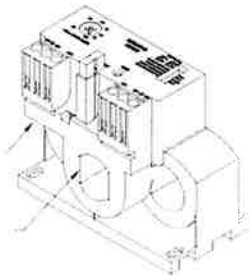

E-6518  
25-100 Amps

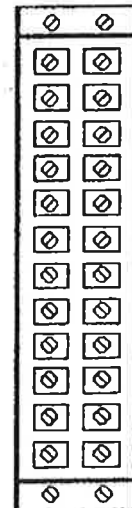

E-5366  
Terminal  
Bd.  
12 PT.



E-5008-01  
Ground Lug

Delux Add-On Panel, 1 Phase, 5 HP  
A0CC1P5HP

Add On Control Circuit, 297A-001A

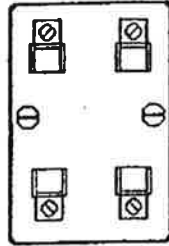

E-5001-02  
Fuse Block  
2 Circuit, 60A



E-5001-03  
Fuse Block  
1 Circuit, 30A

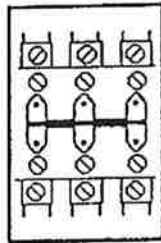

E-6511

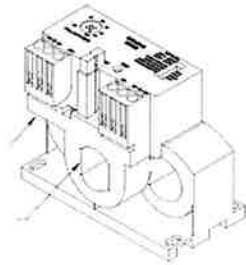

E-6517  
10-40 Amps

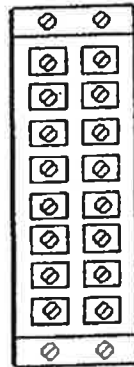

E-5083  
Terminal  
Bd.  
8 Pt.

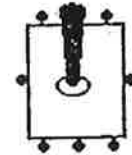

E-5006-04  
Switch  
(Three Pole,  
Double Throw)  
"9-Terminal"

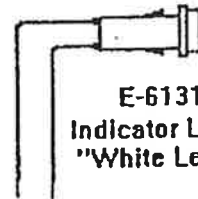

E-6131  
Indicator Lamp  
"White Lens"

Delux Add-On Panel, 3 Phase, 10 HP  
AOCC3P10HP

Add On Control Circuit, 297B-001A

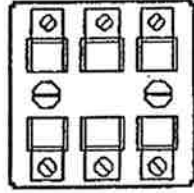

F-5001-01  
Fuse Block  
3 Circuit, 30A

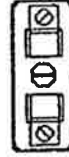

E-5001-03  
Fuse Block  
1 Circuit, 30A

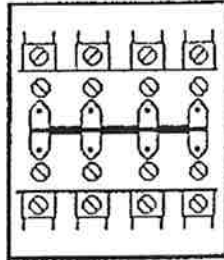

E-6511

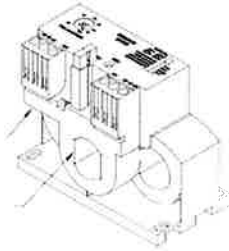

E-6517  
10-40 Amps

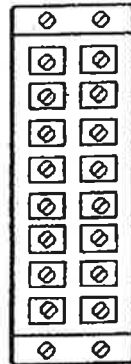

E-5083  
Terminal  
Bd.  
8 Pt.

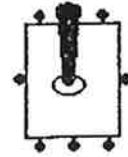

E-5006-04  
Switch  
(Three Pole,  
Double Throw)  
"9-Terminal"

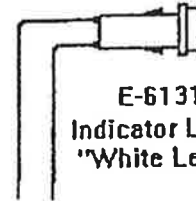

E-6131  
Indicator Lamp  
"White Lens"



Delux Add-On Panel, 1 Phase, 10 HP  
AOCCIP10HP

Add On Control Circuit, 297C-001A

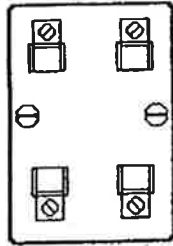

E-5001-02  
Fuse Block  
2 Circuit, 60A



E-5001-03  
Fuse Block  
1 Circuit, 30A

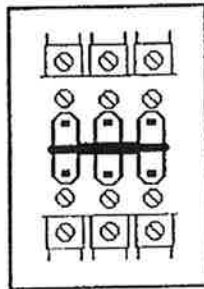

E-6513

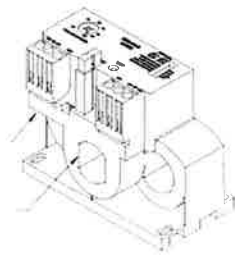

E-6518  
25-100 Amps

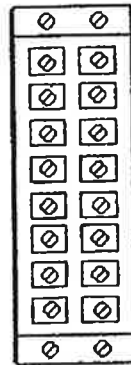

E-5083  
Terminal  
Bd.  
8 Pt.

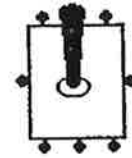

E-5006-04  
Switch  
(Three Pole,  
Double Throw)  
"9-Terminal"



E-6131  
Indicator Lamp  
"White Lens"

Delux Add-On Panel, 3 Phase, 440V, 10 HP  
AOCC3P440

Add On Control Circuit, 297D-001A

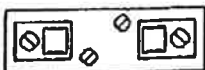

E-5001-03  
Fuse Block  
1 Circ. 30A

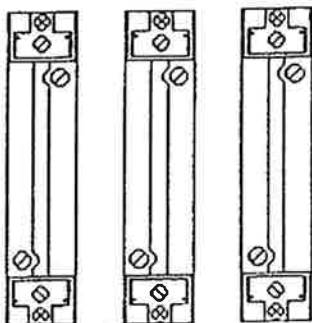

E-5142 (3)  
Fuse Holder  
600V 30A

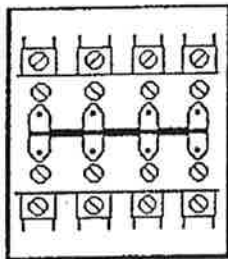

E-6511

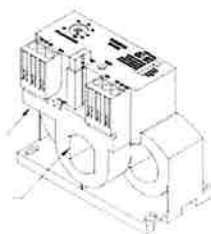

E-6511  
10-40 Amps

E-5083  
Terminal  
Bd.  
8 Pt.

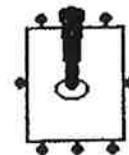
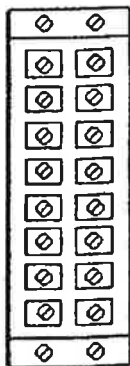

E-5006-04  
Switch  
(Three Pole,  
Double Throw)  
"9-Terminal"

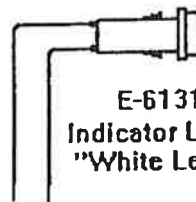

E-6131  
Indicator Lamp  
"White Lens"

Delux Circu-trol Switch Mtg. Plate  
295-235A

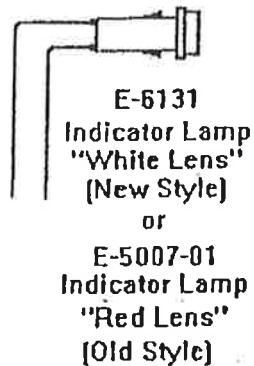
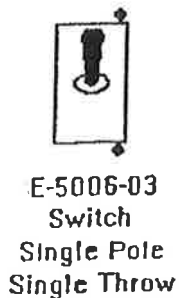
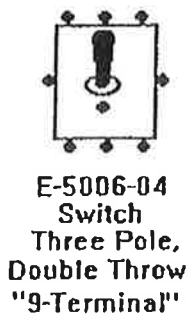
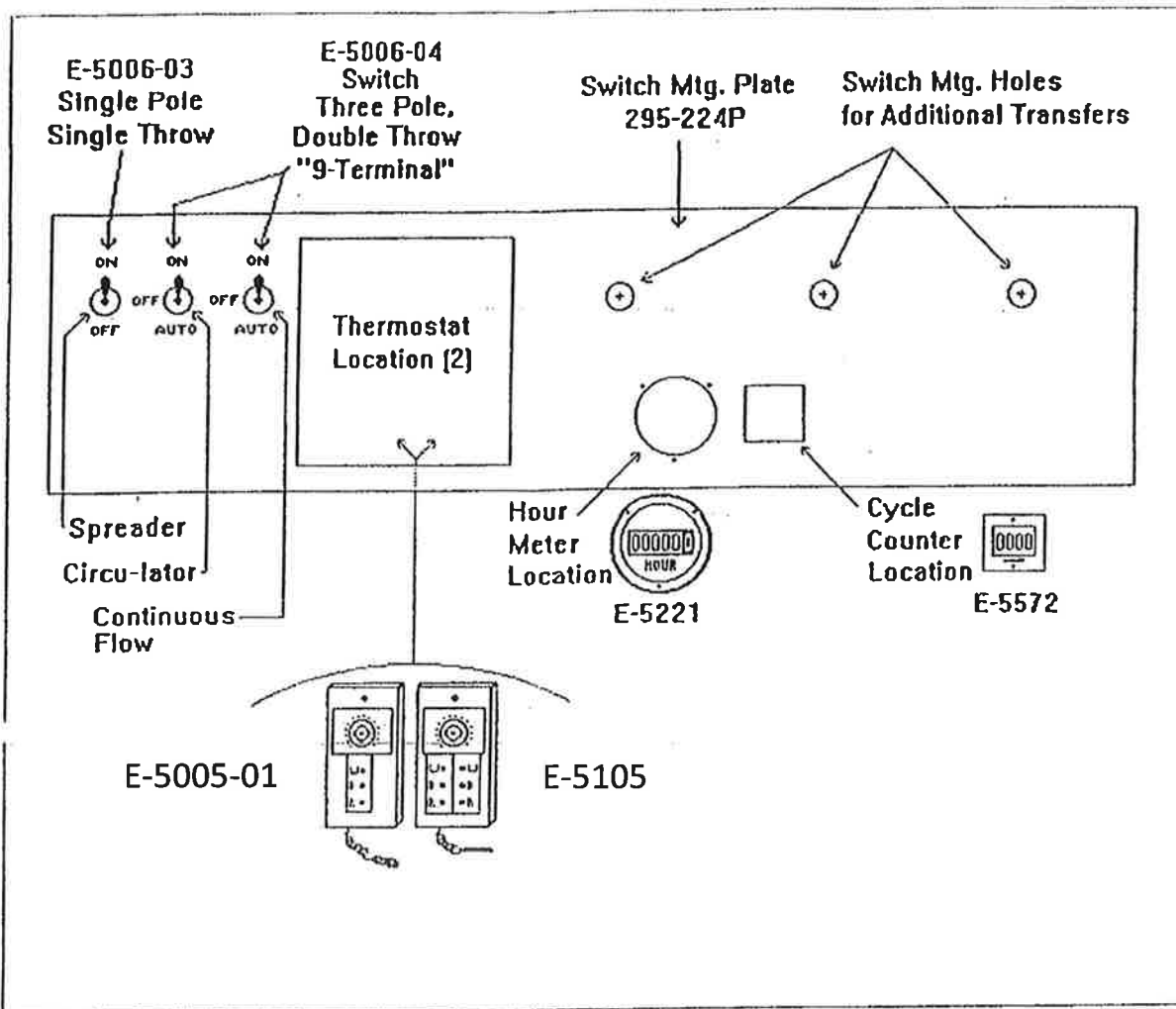

641-038A

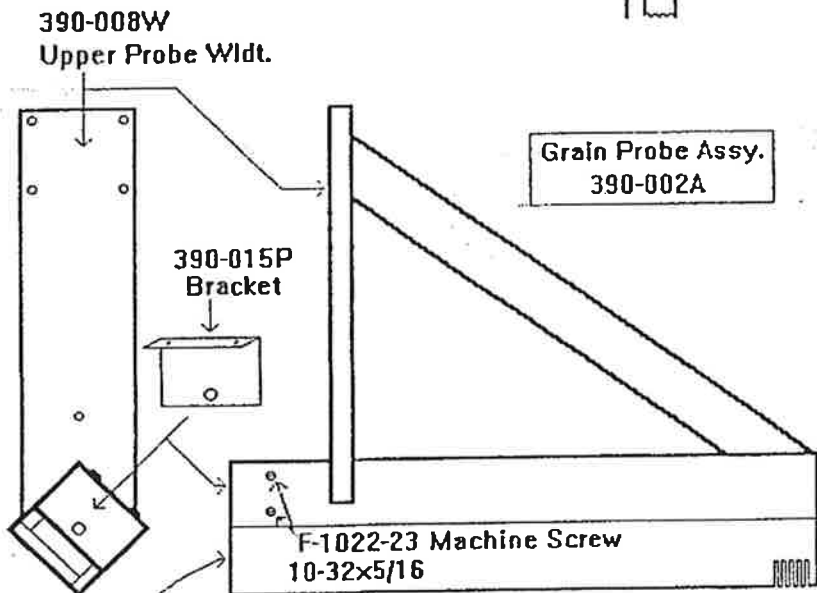
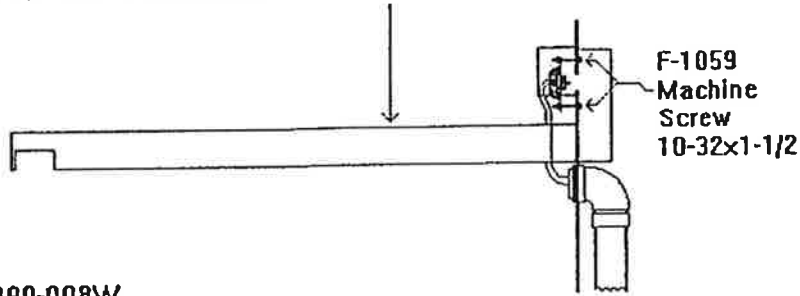
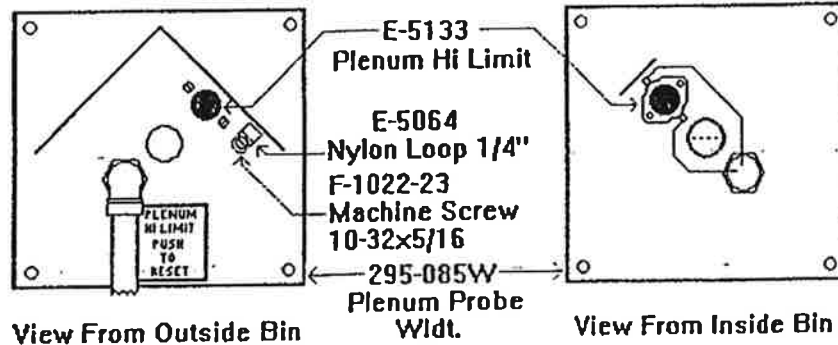

- 390-003A Insulation Assembly  
Consisting of:
- 390-012P Notched Insulation  
Qty. per Assy. (2)
  - 390-013P Plain Insulation  
Qty. per Assy. (2)