

INSTALLATION MANUAL

for SHIVERS

CIRCU-LATORS I & II

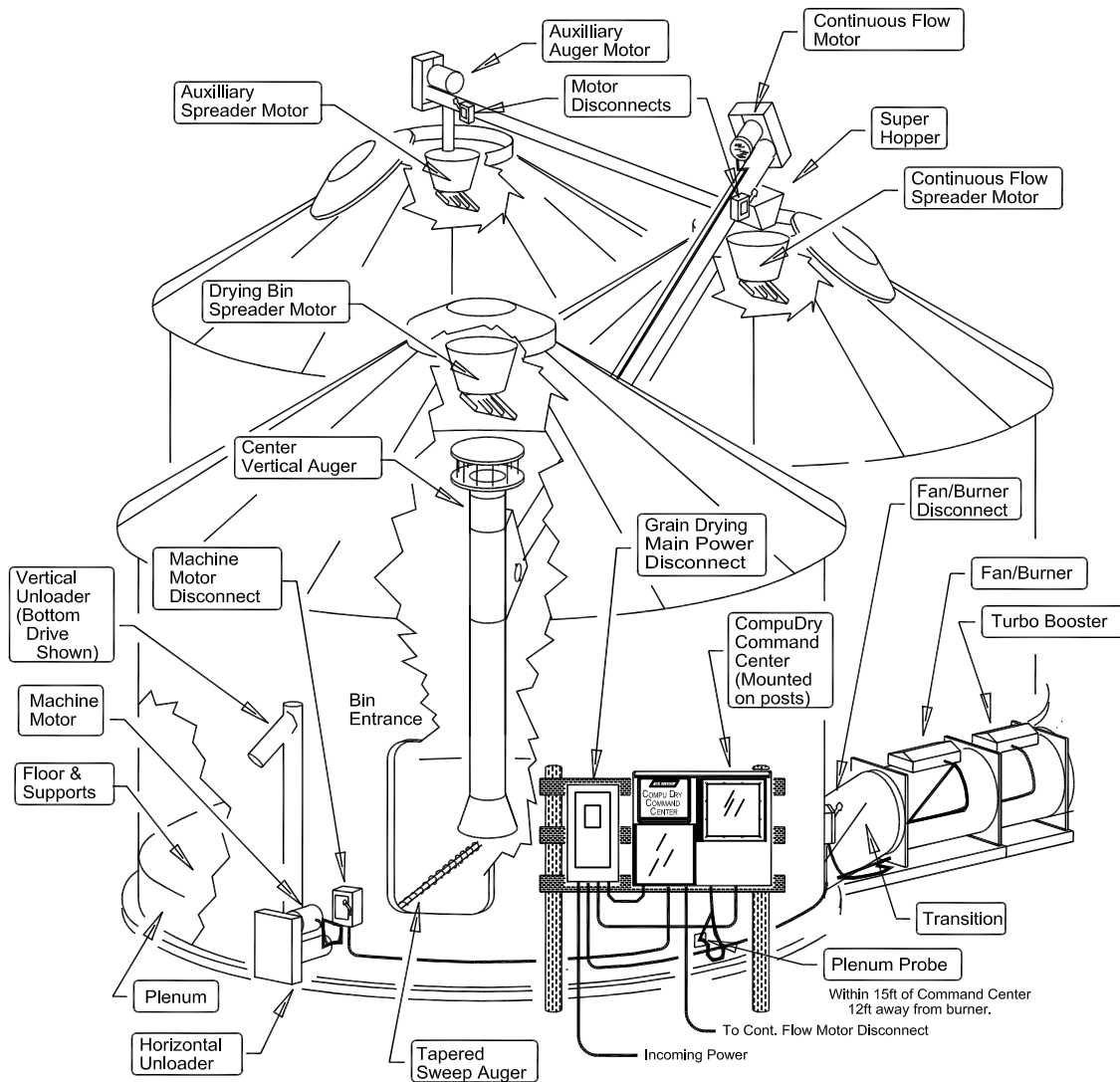

Shivers Manufacturing, Inc.
 614 W. English St.
 Corydon, IA 50060
 Ph. (641) 872-1005 ** Fax (641) 872-1593
 www.shivers.com

P-8781
 9/21/2018

Table of Contents

Introduction	2
Safety Information	3-4
Bin Layout	5-9
Installing Horizontal Unloader and Gearbox Basket	10-28
Tapered Sweep and Wear Track Installation	29-31
Center Vertical Installation	32-37
Installing Safety Decals and Locks	38-42
Circulator Installation Final Check	43

Introduction

The purpose of this manual is to give instructions on the installation of Shivers Circu-lators. Because there are so many different combinations of equipment that can be installed, this manual will often have to reference the installation manuals for other pieces of equipment. Read through all installation manuals and use all of them together to determine the best plan of action for your installation. Equipment designs change and it is hard to keep all the installation information up to date on a system with this many parts. If you have any questions, contact Shivers for clarification.

It is important that the sales personnel and the installation crew maintain good communication at all times so that each is fully aware of the requirements for bin layout, equipment location, and farmer's expectations.

ATTENTION

The Shivers Circu-lator will set up flow patterns of grain which exert extra stress on the walls and floor of the drying bin. **Additional floor supports are normally required for the drying floor. Bin sidewall stiffeners are often required.** Consult bin and floor manufacturer for their recommendations before installing and using the Shivers Circu-lator. Shivers will not be responsible for structural failure of the drying floor or bin, or for any loss, damage, or injury relating to use of the Circu-lator.

Large amounts of water are removed during the drying process. A way to remove this water from inside the drying bin is required. This is usually accomplished by installing roof vents. **We strongly recommend having the bin roof raised about 3/4" above the bin side wall.** This is especially important while drying when outside temperatures are below freezing. Having the roof raised will keep a lot of the condensation from running down the inside of the bin wall.

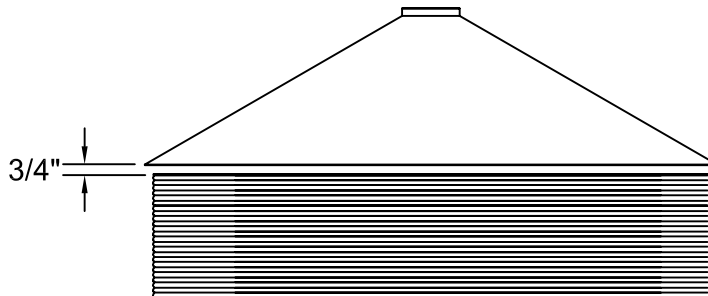

Safety Information

The user of this equipment must assume responsibility for his or her own safety and for the safety of those working with them.

If any items covered in this manual are not completely understood, or there is a concern with the safety of the product, contact Shivvers at the address shown on the front cover.

Read and understand the Operator's Safety Manual (P-10001), and all applicable operator's manuals, before working on Shivvers equipment.

Read and understand this manual completely before using this equipment.



Take note anytime this safety alert symbol appears. Your safety, and that of persons around you, is at stake.

The safety alert symbol will be accompanied by one of three signal words whose definitions are given as:

DANGER: Red and white. Indicates an imminently hazardous situation that, if not avoided, will result in death or serious injury. This signal word is to be limited to the most extreme situations, typically for machine components that, for functional purposes, cannot be guarded.

WARNING: Orange and black. Indicates a potentially hazardous situation that, if not avoided, could result in death or serious injury, and includes hazards that are exposed when guards are removed. It may also be used to alert against unsafe practices.

CAUTION: Yellow and black. Indicates a potentially hazardous situation that, if not avoided, may result in minor or moderate injury. It may also be used to alert against unsafe practices.

Installation Safety

Using a tagged padlock, lock off all sources of potential energy before beginning the installation!

All electrical wiring shall be installed in compliance with the latest addition of the ANSI/NFPA Standard 70, National Electrical Code, as a minimum requirement, and in compliance with local wiring codes as applicable.

Wiring must be done by a competent electrician. A licensed electrician is recommended, and must be used when required by local or state statutes.

The installation of this equipment will require special tools such as an oxy-acetylene torch (cutting torch), ladders, safety belts, power tools, and power cords with GFCI (ground fault circuit interrupter). The safe operation, use, and condition, of this equipment is the responsibility of the contractor, or persons involved in their use.

Avoid dusty conditions (especially on existing bins where grain has been stored), to prevent fires or explosions caused by combustion. Wear a dust mask.

Safety Decals and Locks

Field installable safety decals are supplied with this equipment. See section on Installing Safety Decals and Locks in this manual. If more decals are needed, contact the factory for additional ones.

Field installable safety lock kits are supplied with this equipment. See section on Installing Safety Decals and Locks in this manual.

Make sure all decals and the safety lock kits are installed on the system as shown in this manual and the Operators Safety Manual (P-10001) before the equipment is put in use.

Bin Layout

It is best to align the drying and storage bins so that the Continuous Flow Auger does not go through a roof seam. If it does, it can lead to installation delays and sealing problems. See the diagram below for layout examples.

Dryer & Storage Bin Orientation

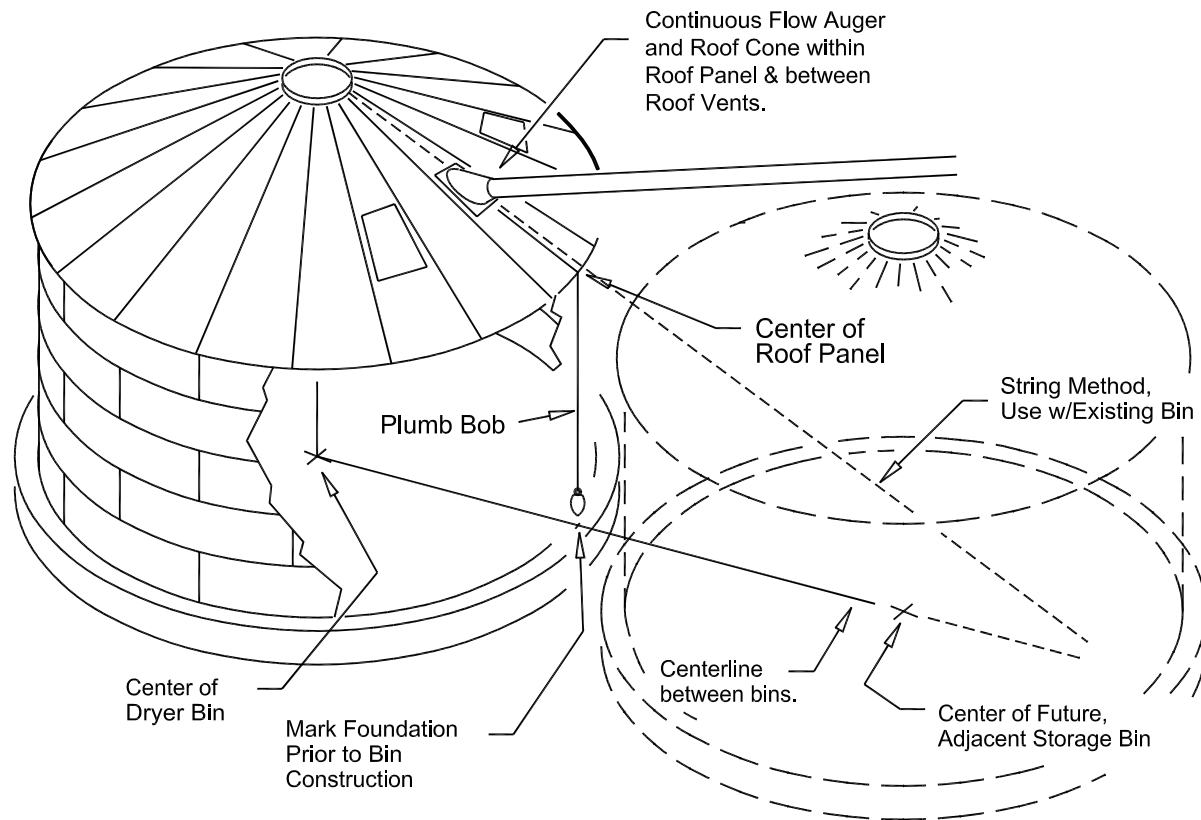

On new installations, mark where the centerline between the bins crosses the outer edge of the dryer bin foundation. Line up the centerline of a roof panel to the mark on the foundation, using a plumb bob if necessary.

When a storage bin is being added to an existing drying bin installation, the centerline can be determined by tying a string to the center of the roof panel near the opening at the top of the bin, then stretching it outwardly from the bin and in alignment with the center of the roof panel as shown. In most cases, the position of the storage bin can be adjusted to line up with the center of the roof panel.

Bin Layout (cont'd)

The concrete pad for the the drying bin should be as close to flat and level as possible. Make sure it is thick enough and has enough reinforcement so it will not crack and move. Consult the bin manufacturer for more information. A good, solid, flat and level foundation is required for the Circu-lator to work properly.

See fan and burner installation manuals for instructions on concrete pads for them. See suggested layouts in this manual for orientation of fans, horizontal unloader, and control boxes. The suggested layouts show pad sizes for Shivvers Blue Flame dryers. They also show a Compudry Command Center for the control box. Your installation may have something different, but the orientation should be similar. Try to align the bin sheets so the fan/burner entrance collar(s) do not have to be cut through a seam.

The Horizontal Unloader must come out near the main entrance door of the bin.

The control box must be within line of sight of the bin's main entrance door.

There must be a main electrical disconnect switch. This switch must shut off all electrical power to the drying system. It must have the capability of being locked in the OFF position. It must be located near the bin's main entrance and within line of sight of the control box.

A lockable disconnect switch for the Machine (Circu-Lator or Dri-Flo) Motor is required near the bin entrance. This disconnect switch is NOT supplied by Shivvers, but can be obtained locally.

A switch to control the drying bin spreader is also required, but not supplied by Shivvers.

Since the Shivvers drying system can operate at temperatures up to 200° F, all sealants in the plenum area must be able to withstand this temperature. Ordinary plastic roofing cement or tar will soften and should not be used. Possible materials to use are:

- (1) Black Jack #1010, Neoprene Flashing Cement, by Gibson-Homans
- (2) Regular 100% Silicone Caulking
- (3) Stretch-a-Seal (™), Bin and Elevator Sealant, by Farm Products Direct
(Follow manufacturer's instructions) Ph (800)669-9314
- (4) Rubberflex Binseal Ph (800) 817-2986

All air leaks in the bin must be sealed off. The sealant should be applied from the inside of the plenum area, if at all possible. If it is applied from the outside, plenum pressure will probably blow it out.

Bin Layout (cont'd)

Shivvers Circulator 1-Fan Layout

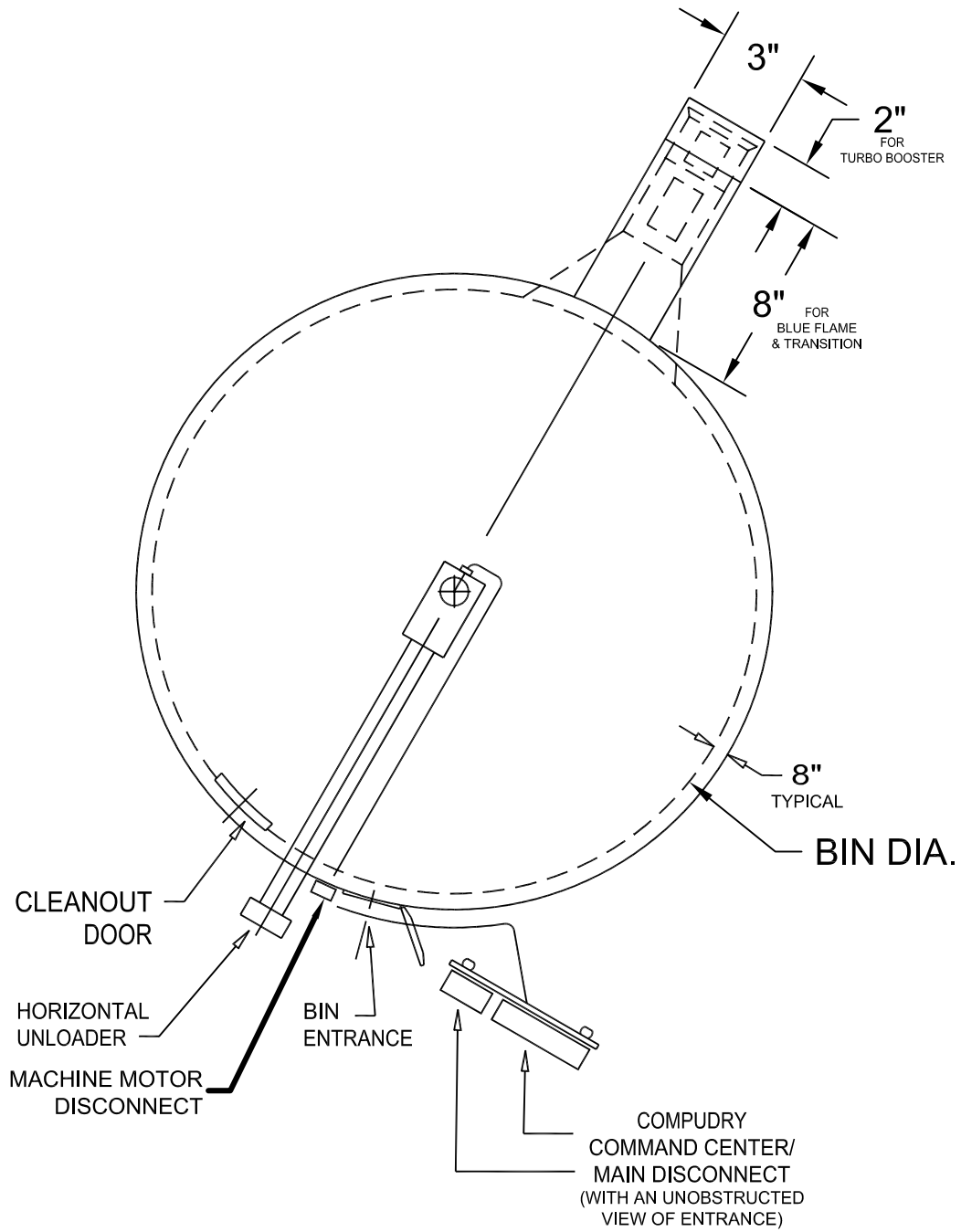

FANLYT-1.DWG

Bin Layout (cont'd)

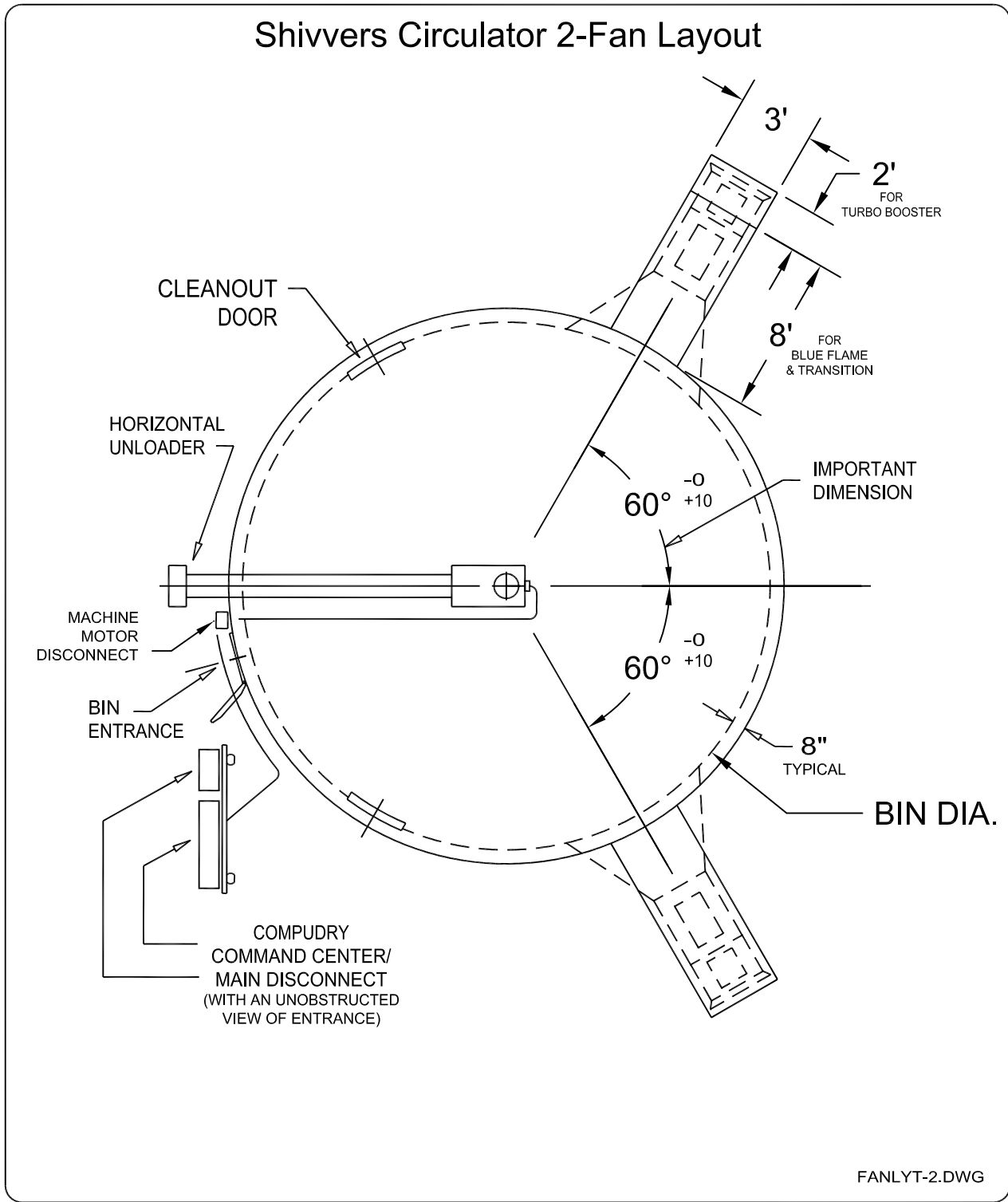

Bin Layout (cont'd)

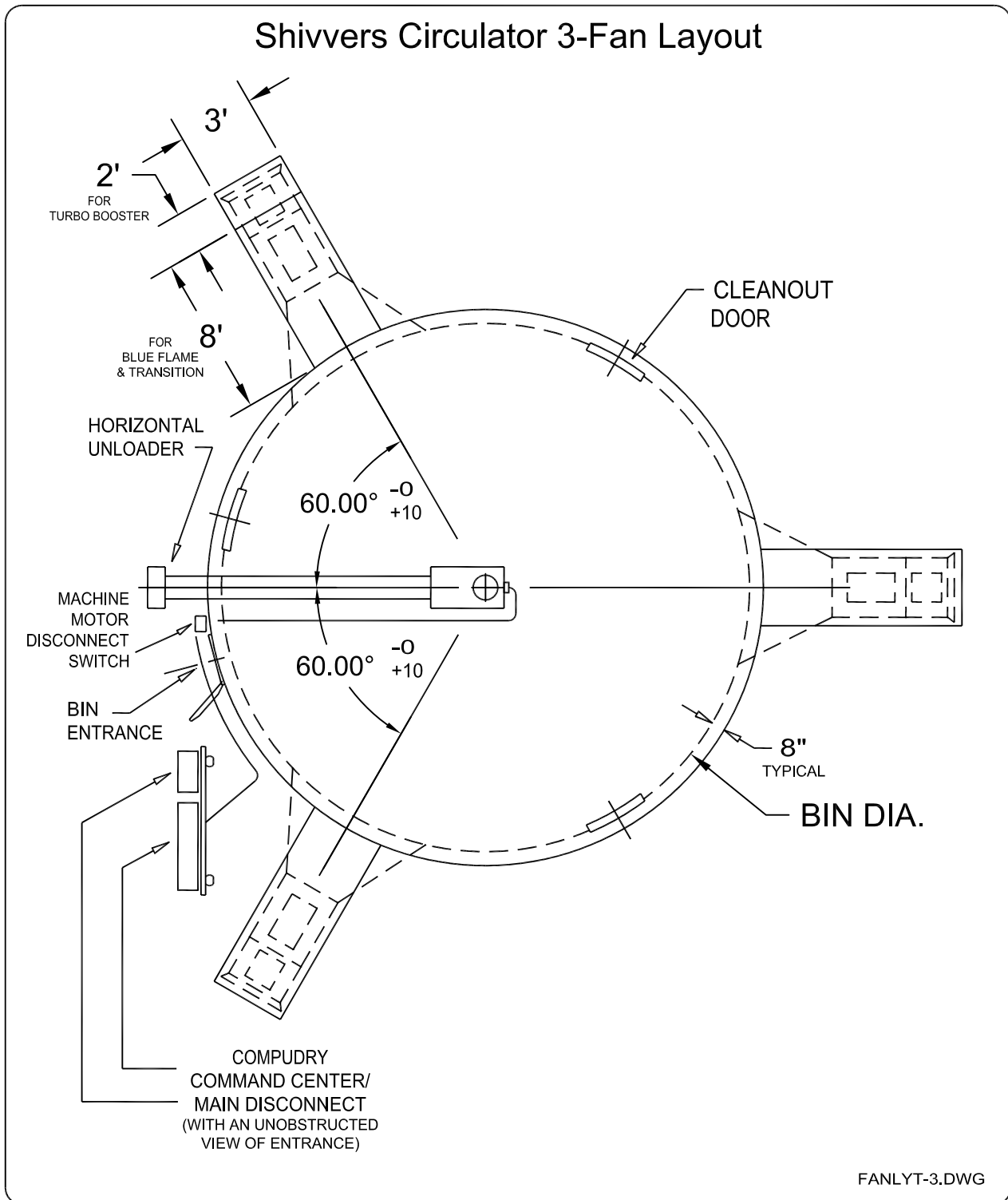

Installing Horizontal Unloader and Gearbox Basket

Step 1:

For installations in existing bins, it is recommended that the floor be removed. If the old floor is going back in, number the individual floor pieces for convenience of reinstallation. The entire concrete bin floor should be cleaned.

Step 2:

Determine the location where horizontal unload tube will project through the bin sidewall. It should be within sight of the bin entrance and the dryer controller. At this location, measure down 8-1/2" from where the top of the floor will be. This will be the center of the horizontal unload tube.

FOR SHIVERS FLOOR AND SUPPORTS			
Leg Designator	Leg Height	Top of Floor	Concrete floor to Center of Horizontal
* S	11.46"	12-5/8"	4-1/8"
M	15.68"	16-7/8"	8-3/8"
T	16.25"	17-7/16"	8-15/16"

* = Not recommended for high temperature drying. It will be necessary to grind off projections on bottom of gearbox basket and to shorten bottom of faceplate.

Hold the faceplate against the bin wall, with the control rod hole on top, and mark all holes on the bin wall. Cut a keyhole shape in the bin wall for the unload tube and control rod. Hanger bearing unloaders will require a larger hole. Make sure the faceplate will cover the hole that is cut.

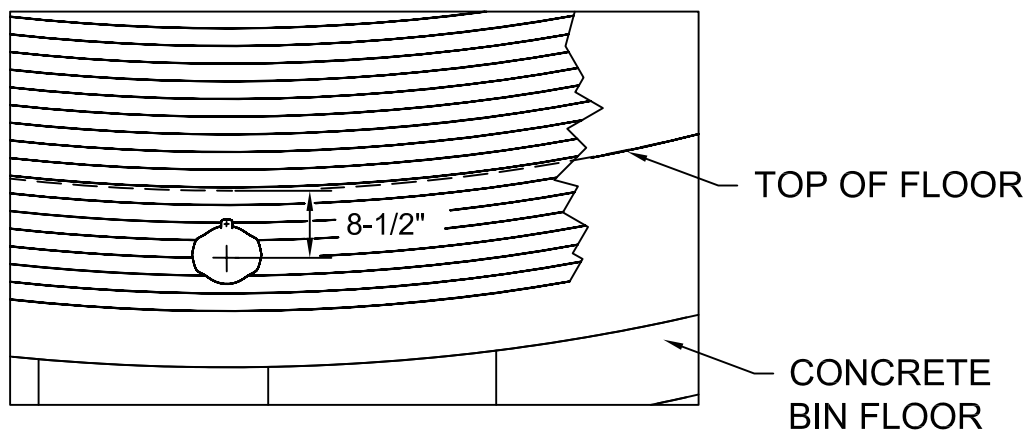

Installing Horizontal Unloader and Gearbox Basket

Step 3:

Unless the faceplate is a two piece design, place the faceplate on the horizontal unload tube as shown, and insert the unload tube through the hole cut in the bin wall.

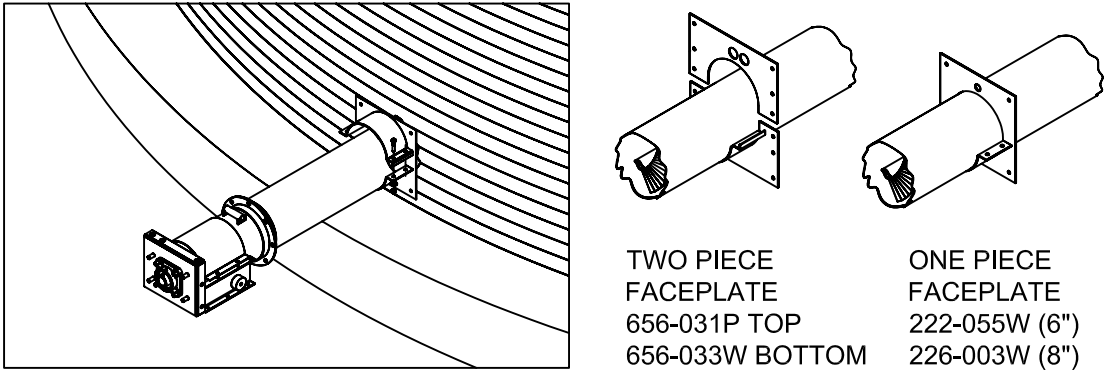

Step 4: Prepare gearbox and basket for installation.

Check the gearbox to insure it is lubricated. Remove the shipping wire that holds the top gearbox to the bottom gearbox. Screw jam nuts, from the 222-085A Basket Hardware Sack, on the 3/4" x 12" support legs approximately 9". Screw the support legs, with jam nuts, into the basket until the top of the basket will be at about the same height as the drying bin floor.

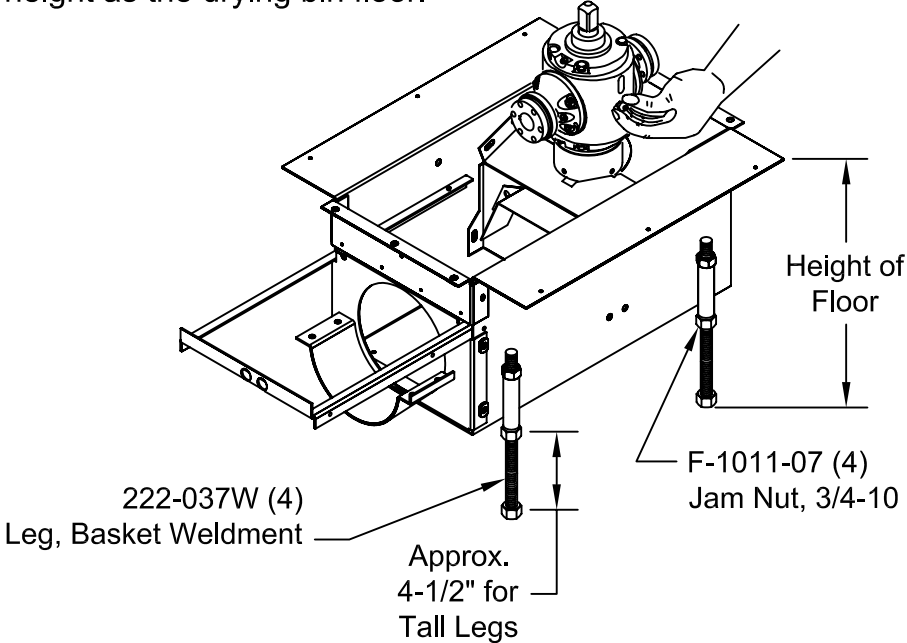

Installing Horizontal Unloader and Gearbox Basket

Step 5:

Install the front plate on the basket with hardware from 222-085A, Basket Hardware Sack, as shown. The bottom lip on the front plate goes inside the basket and the sides of the front plate go outside the basket. Temporarily remove the chain coupler guard from the basket.

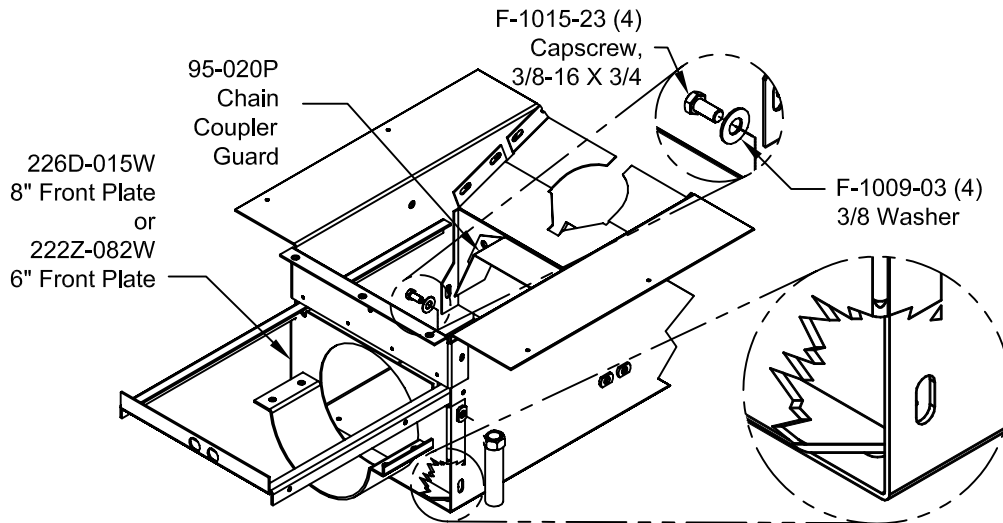

Step 6:

Slide the horizontal unload tube into the basket. Temporarily clamp the horizontal unload tube to the basket with hardware from 222-085A, Basket Hardware Sack. Do not tighten yet. The end of the unload tube should be about flush with the inside front plate of the basket.

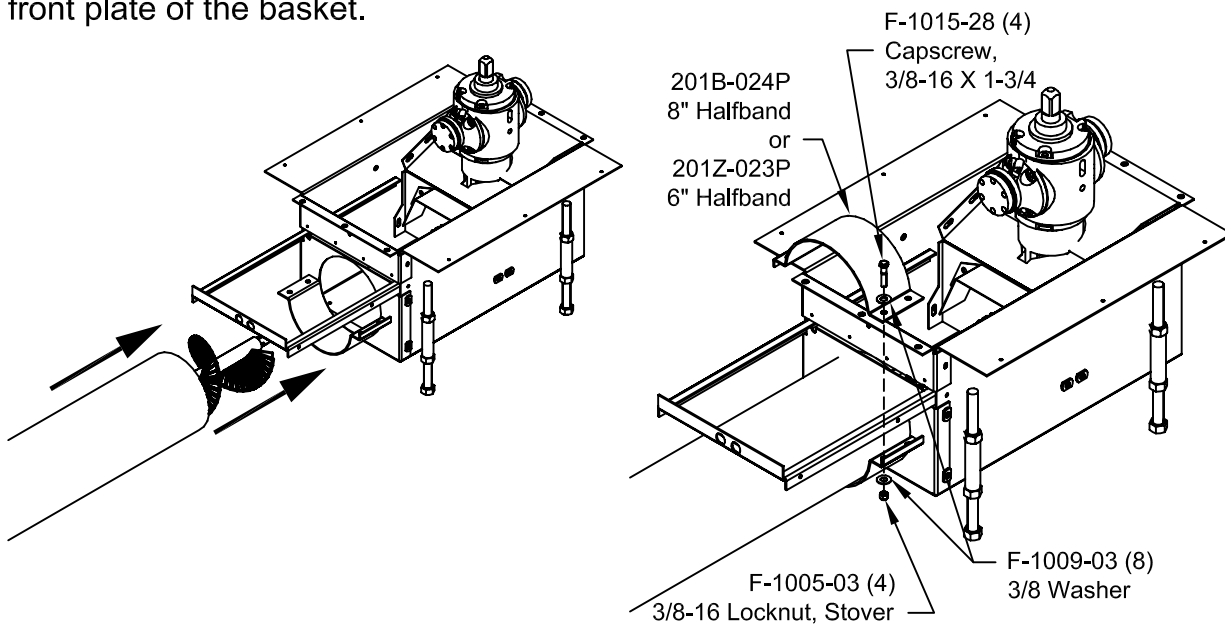

Installing Horizontal Unloader and Gearbox Basket

Step 7:

Using the 222-029A sack labeled "Chain Coupler," connect the drive shaft of the horizontal unloader to the gearbox input sprocket.

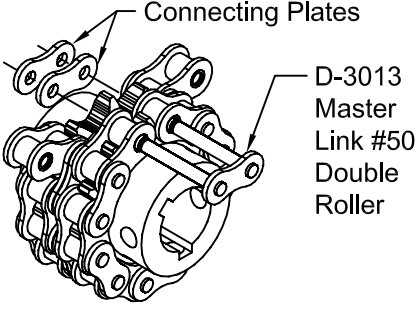
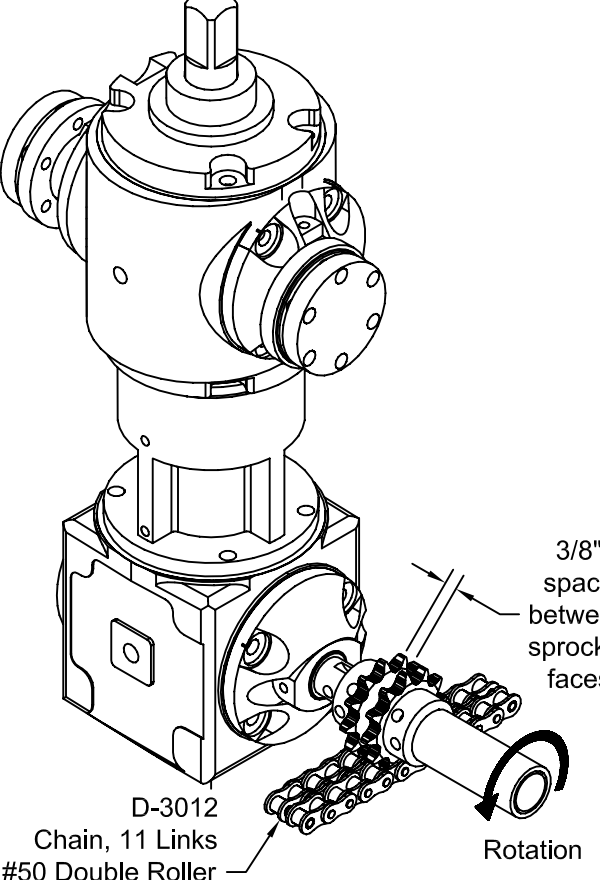
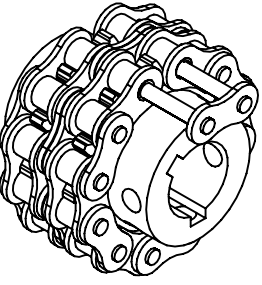
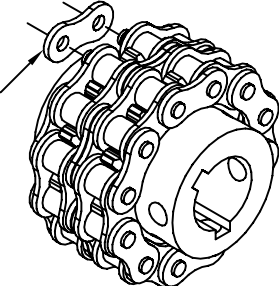
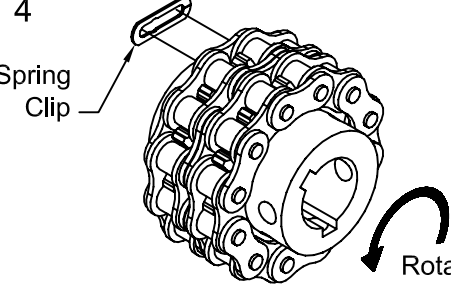
<p>1</p>  <p>Connecting Plates</p> <p>D-3013 Master Link #50 Double Roller</p> <p>Slide pins of master link through chain farthest from gearbox with chain closest to gearbox folded back. Insert 2 connecting plates between chains, while sliding in master link pins.</p>	 <p>3/8" space between sprocket faces</p> <p>D-3012 Chain, 11 Links #50 Double Roller</p> <p>Rotation</p>
<p>2</p>  <p>Fold inside chain back onto sprocket and completely insert master link pins.</p>	
<p>3</p>  <p>Connecting Plate</p> <p>Place another connecting plate on master link pins.</p>	<p>4</p>  <p>Spring Clip</p> <p>Rotation</p> <p>Install spring clip onto master link pins with solid end (not split end) facing toward sprocket rotation. Make sure spring clip is securely seated into master link pin grooves.</p>

Installing Horizontal Unloader and Gearbox Basket

Step 8: Center and adjust basket:

Position the basket so the square shaft on the gearbox is centered in the bin. Check for center in at least four directions around the bin. Adjust the basket support legs until the basket is at the proper height (top of floor) and level in all directions. Shivvers part number 423-351-001A is for a mounting bracket that holds a laser level onto the gearbox. It can be used to make sure the gearbox is square with the concrete bin floor. Weight must be carried by all four support legs. Using a marker or spray paint, mark around the support legs for an easy verification that the basket remains in the center of the bin.

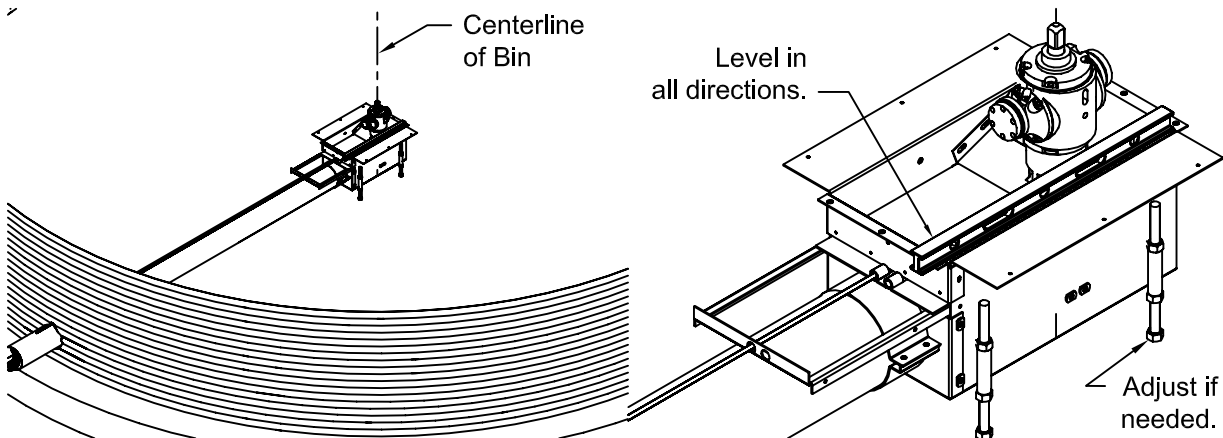

Step 9:

Place level on the horizontal unload tube and temporarily support outside end to level. Trim faceplate hole if necessary. Leave room between temporary support and bin wall so faceplate holes can be drilled and bolts tightened.

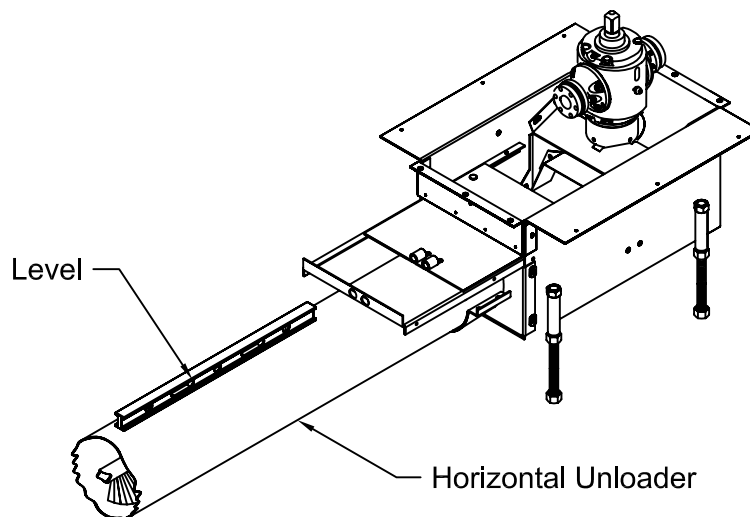

Installing Horizontal Unloader and Gearbox Basket

Step 10:

Drill bolt holes for faceplate. Apply high temperature sealant and mount faceplate to bin wall using hardware in "faceplate" sack. 222-063A for one piece faceplate or 656-036A for two piece faceplate. Do not tighten the halfband clamp yet.

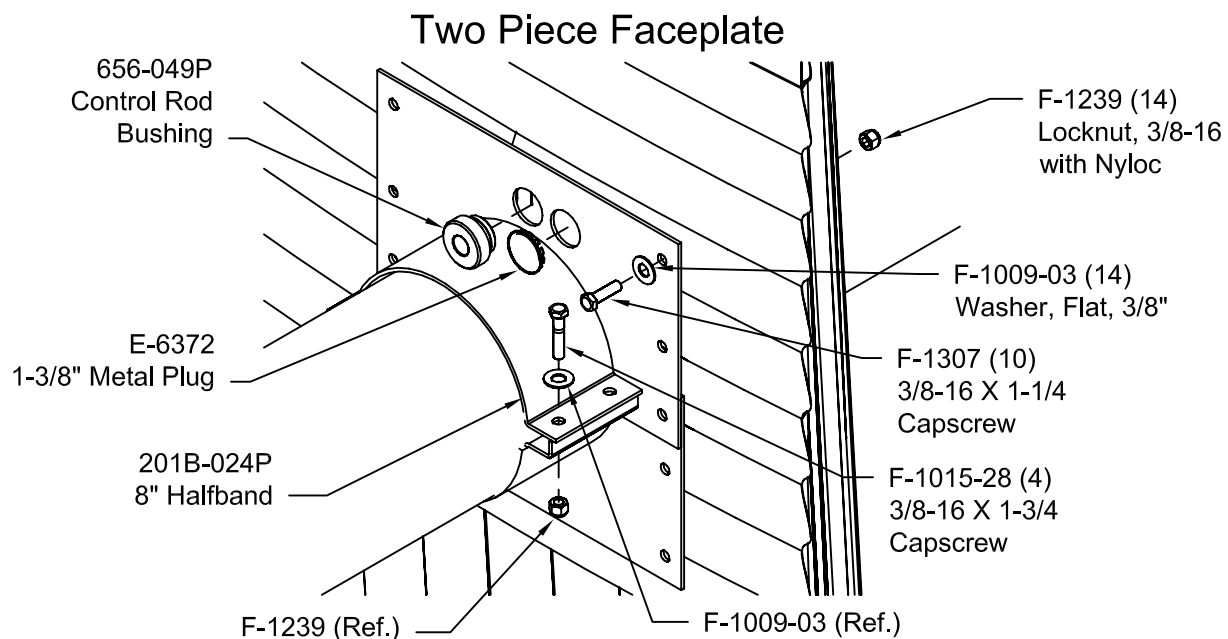
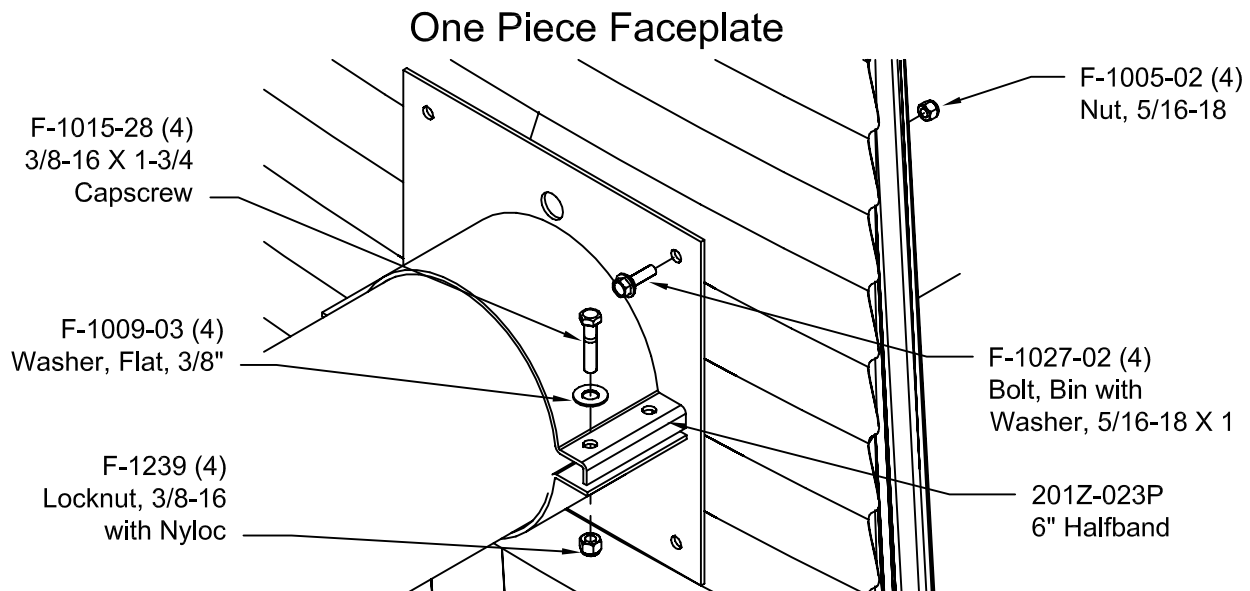

Installing Horizontal Unloader and Gearbox Basket

NOTE: Follow step 11A for installations with an outside vertical auger. Go to step 11B for installations without an outside vertical auger.

Step 11A: For installations with an outside vertical:

With an outside vertical, the horizontal unload tube is rotated 90° for the vertical to operate. It may be easier to rotate the unload tube so the discharge opening is facing up, then bolt the the vertical auger to it. Attach the downspout to the vertical auger. The whole assembly can then be rotated into position and attached to telescoping support legs bolted to the bin. It may be necessary to place some temporary supports under the assembly. Attach latch draw to belt shield back in lower set of holes. Attach the belt shield back, from the 423-348-001A belt shield kit, to the horizontal unloader, using the hardware from 225-079A belt shield sack, as shown, then proceed to step 11C.

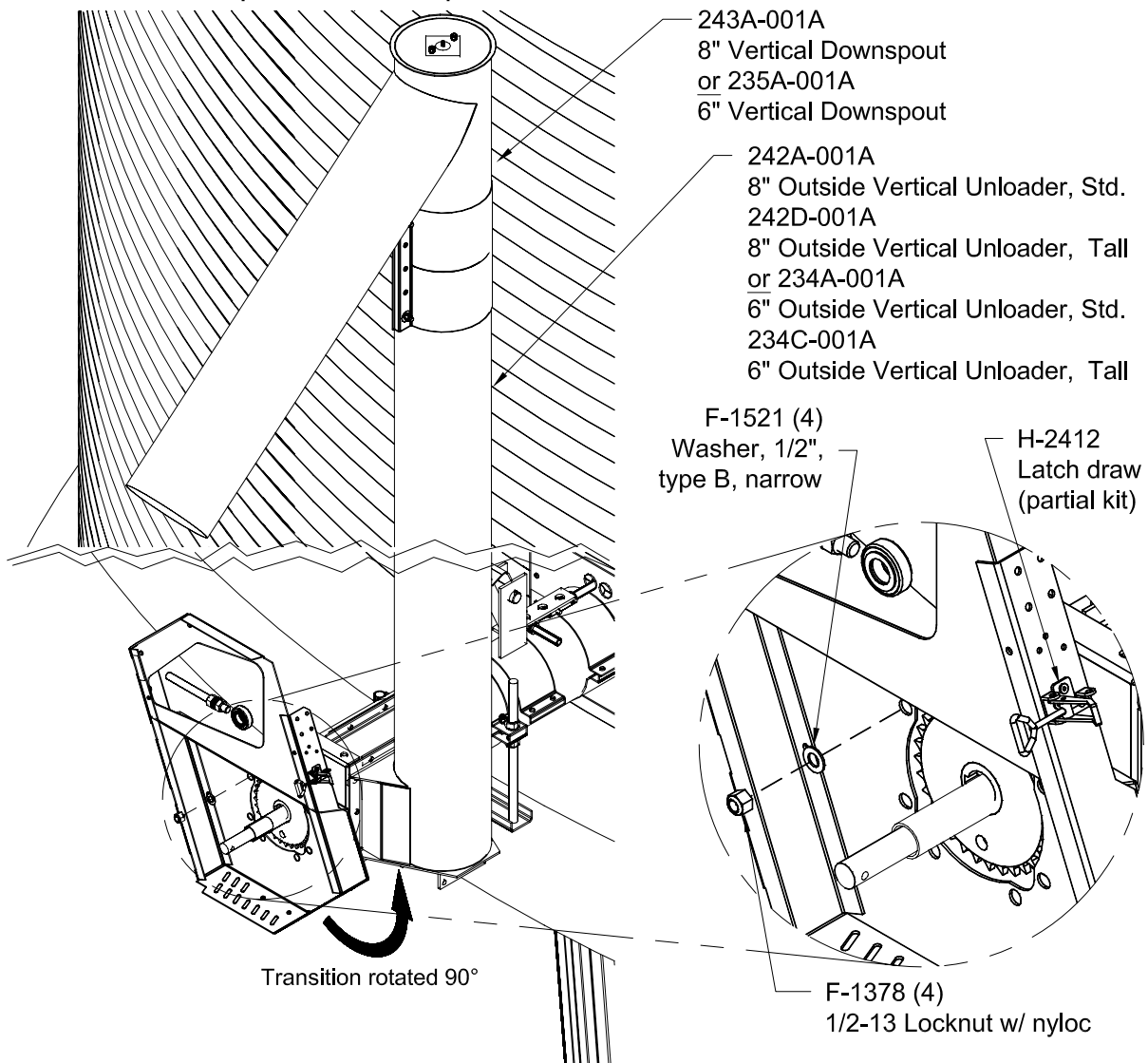

Installing Horizontal Unloader and Gearbox Basket

Step 11B: For installations without an outside vertical:

Attach latch draw to belt shield back in upper set of holes. Install the belt shield backplate onto the end of the horizontal unloader and secure it as shown. Proceed with Step 11C.

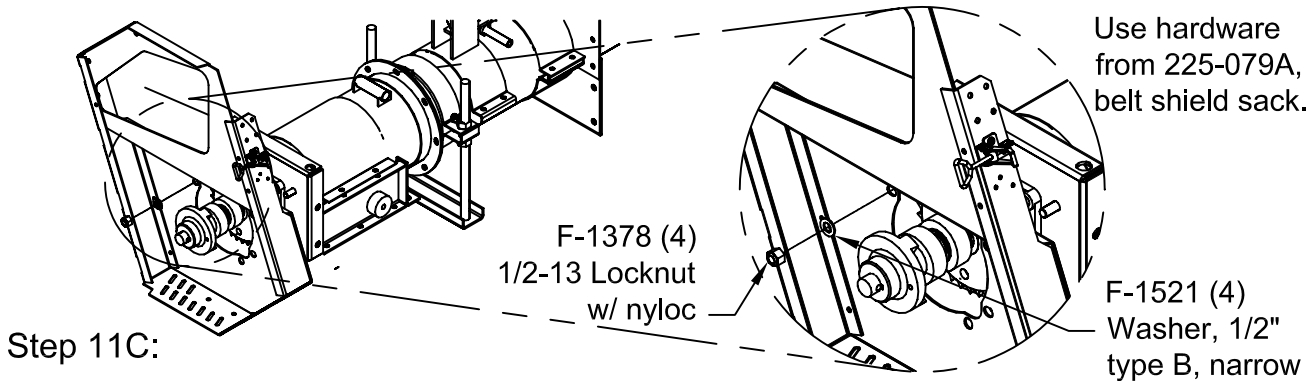

Remove the roll pin and 3-jaw clutch from the 1" drive shaft of the horizontal unloader. Slide the 15" 3-groove pulley onto the 1-3/8" flite weldment tubing of the horizontal unloader until it is almost touching the 32 tooth sprocket. Make sure the 3 notches of the 15" pulley are facing away from the 32 tooth sprocket. The front bearing should be about flush with the end of the 1-3/8" tubing. Tighten all four bearing set screws (2 front and 2 rear) of the 15" pulley. This attaches the 15" pulley to the unloader flite weldment. Make sure the clutch pin of the 15" pulley will engage into the 32 tooth sprocket.

Check that the 15" 3-groove pulley clears the belt shield. If it doesn't, loosen the set screws in the 4 hole bearing and pull more of the 1-3/8" flite weldment tube toward the outside of the bin.

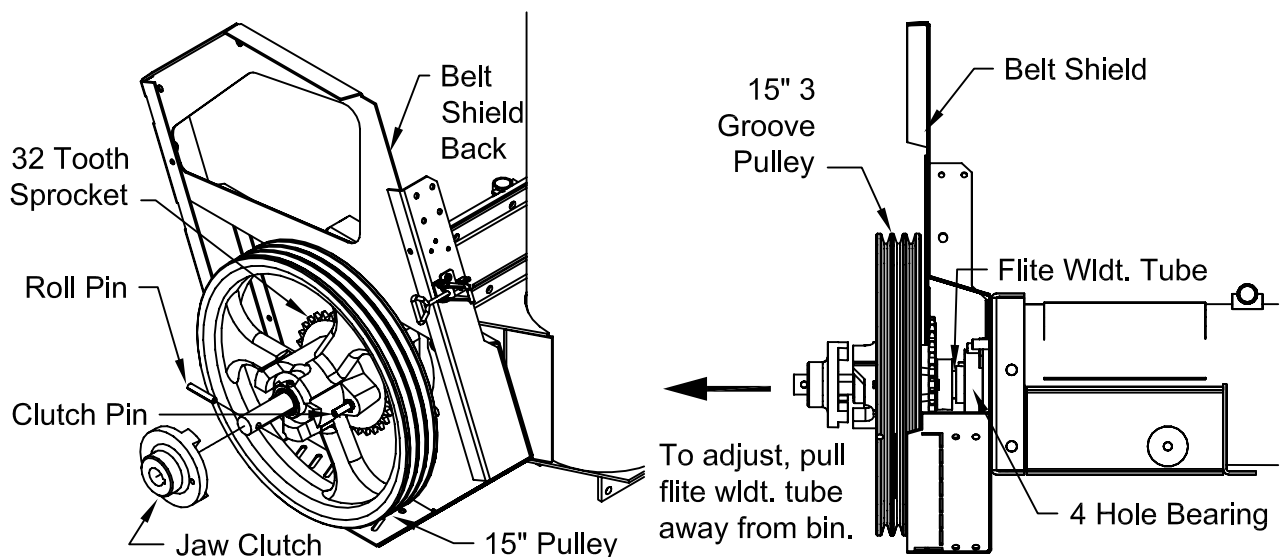

Installing Horizontal Unloader and Gearbox Basket

Step 12:

Replace the 3-jaw clutch and roll pin. Apply anti-sieze to allow easy movement of the 3 jaw clutch. Make sure there is enough of the 1" drive shaft extending beyond the 15" pulley to allow complete disengagement of the 3-jaw clutch from the 15" pulley. If not, the complete horizontal unloader must be pushed inward (into the basket), until clearance is achieved. Loosen the clamp on the horizontal unload tube at the front of the basket and pull the tube in or out until the 3-jaw clutch operates properly (full engagement and disengagement).

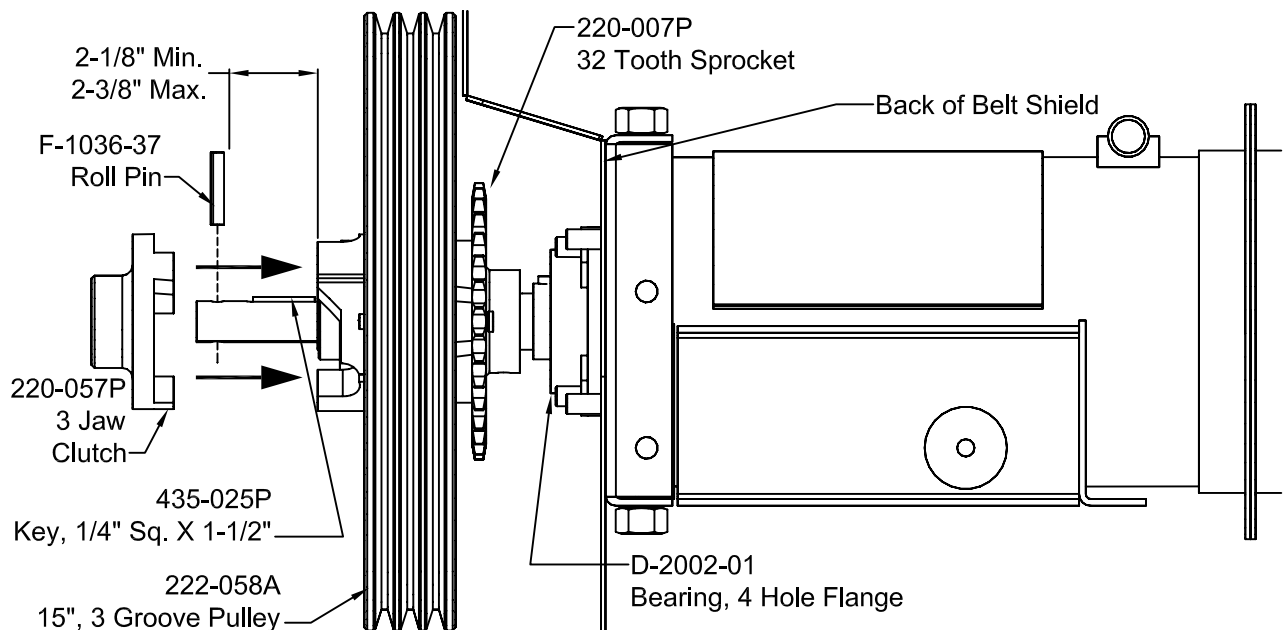

Make sure there is 1/8-1/4" clearance between the 1" drive shaft sprocket and the 1-3/8" unloader fight weldment tubing inside the basket. An O-ring is applied at the factory to help maintain this clearance. Once the unloader is clamped to the basket, the O-ring does not have to remain in place.

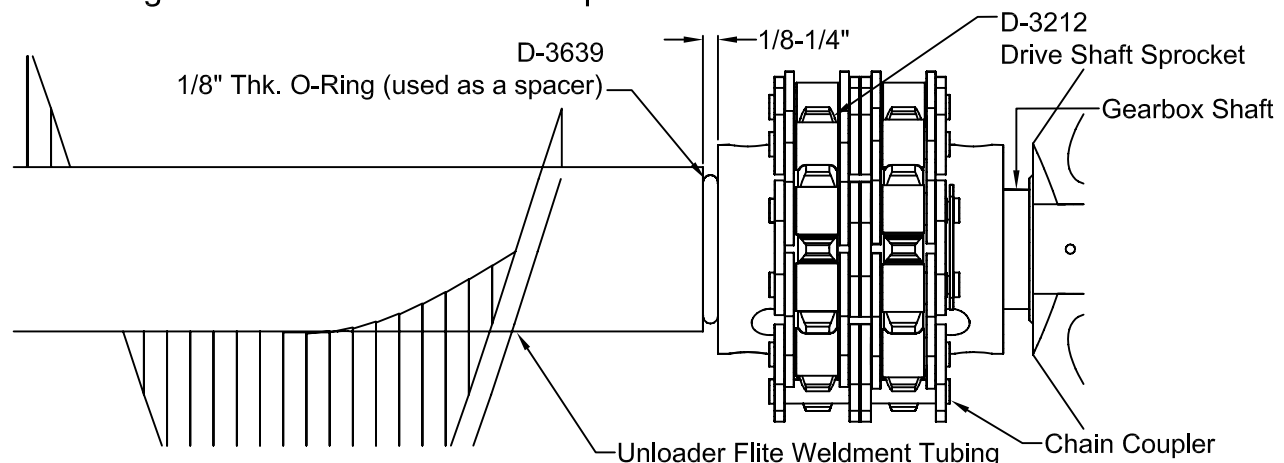

Installing Horizontal Unloader and Gearbox Basket

Step 13:

Make sure the tube discharge hole is pointing straight down and then tighten halfband clamp at the basket. Recheck that the gearbox and basket are still in the center of the bin and tighten the faceplate clamp. Replace the chain coupler guard removed earlier.

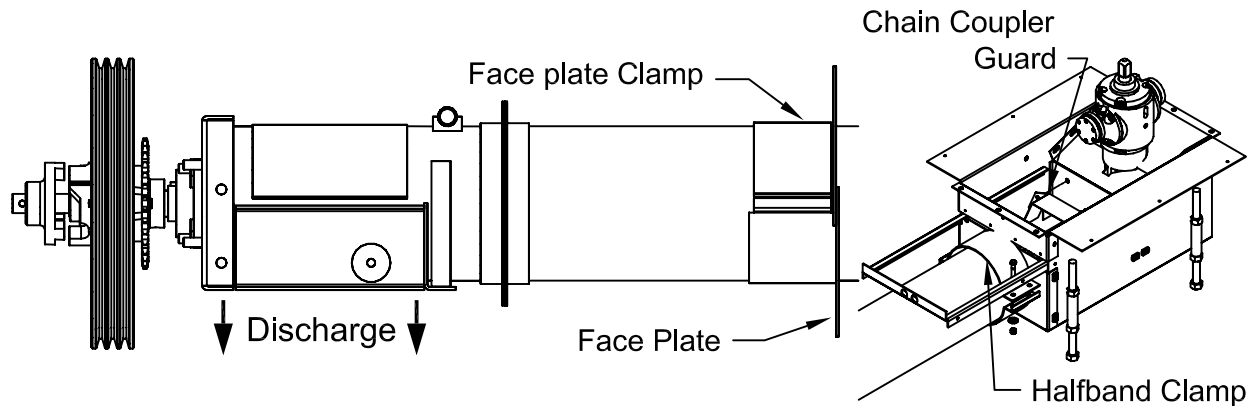

Step 14: Optional Intermediate Well (For more details see Intermediate Well Instructions, P-11584).

If an intermediate well is to be installed, attach it to the horizontal unloader now. Make sure the well is not placed where the tapered sweep auger track will be. Track location will depend on type of sweep auger. For bins under 29' diameter, there is not an inside track. For bins 29' to 33' diameter, the center of the inset wheel track will be either 115" or 145" from the gearbox base, depending on the sweep type. For bins over 33' diameter, the inset wheel track will be either 142" or 145" from the gearbox base. Measure the sweeps to double check inset wheel location. Once the intermediate well is installed, attach a 1" pipe control rod (not included, supplied by dealer) to allow independent operation of intermediate well slide gate. It will be necessary to cut a larger hole in a one piece faceplate for the intermediate well control rod.

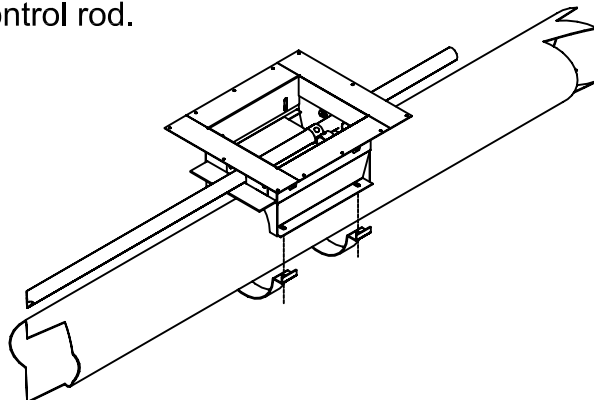

Installing Horizontal Unloader and Gearbox Basket

Step 15:

Install slide gate into the basket as shown. Approximately center control rod guide on unloader tube (guide may not be required if intermediate well is used). Bins over 34' in diameter may require two control rod guides. One is located in the parts box and one is located in the chain and pop parts box. If an intermediate well is not used and a 2 piece face plate is used, install the 656-049P, control rod bushing, into the face plate. Install a E-6372, 1-3/8" metal plug, into the unused face plate hole. Slide control rod through face plate, intermediate well (if used), control rod guide, and basket guide. Screw control rod into slide gate and check operation. Attach either T-handle or optional slide gate opener (Step 16).

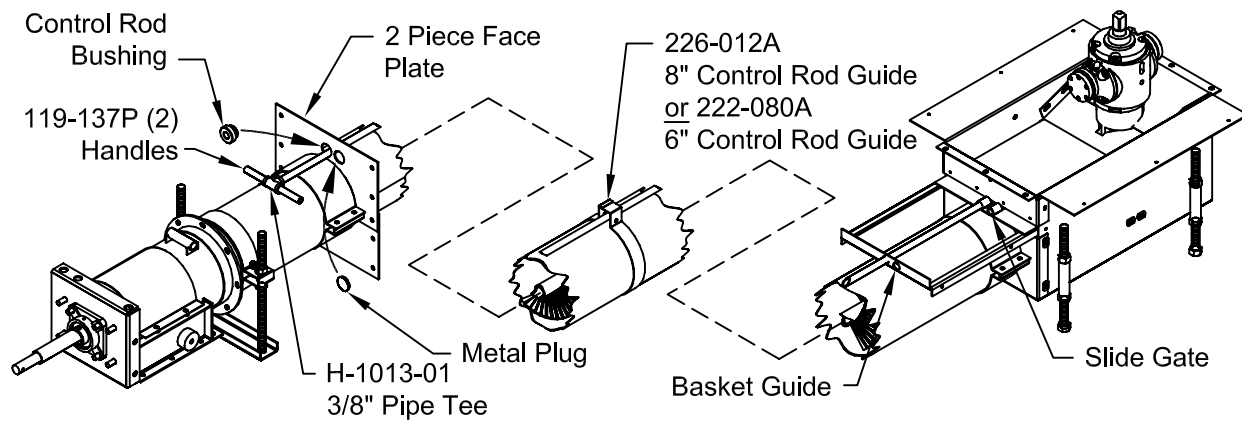

Step 16: Optional slide gate opener (91B-001A for 8" or 91A-001A for 6"). See P-8401 for more details.)

Slide lever rack over control rod and screw pipe cap on end of control rod. With lever rack against pipe cap, drill a 5/16" diameter hole through control rod at hole in lever rack. Install roll pin through both parts. With slide gate closed, center lever pivot with center of first hole in lever rack and clamp halfbands securely. Slide pivot pin through lever pivot and lever and install cotter pins on each side.

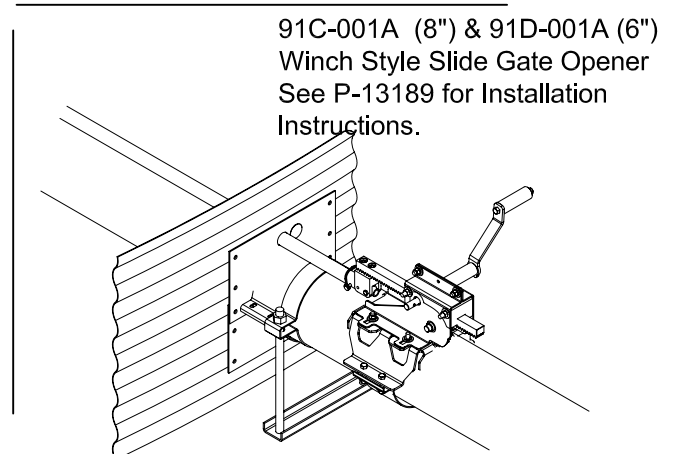
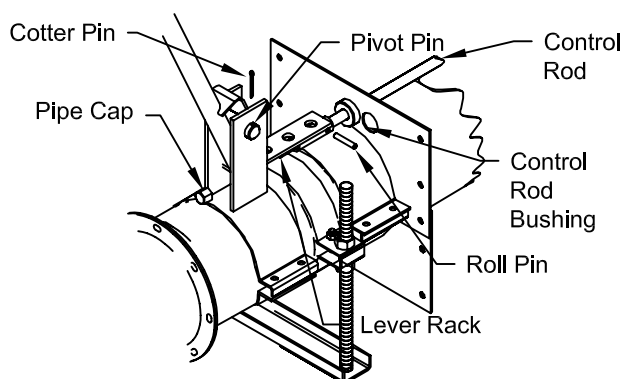

Installing Horizontal Unloader and Gearbox Basket

Step 17: Install conduit for gearbox Hi-limit.

The gearbox Hi-limit will shut off the drying fan(s) if it gets above 240° F. What the gearbox Hi-limit will wire to depends on the type of control and how many fans are used in the installation. If a Compudry Command Center is used, the gearbox Hi-Limit will always wire to it. If 2 or more fans are used, the gearbox Hi-limit will wire to either the dryer control box or a Grain Hi-limit Control box. Only if a control other than a Compudry Command Center is used, and there is only one fan on the bin, will the gearbox Hi-limit go directly to the fan. The important thing is to get the conduit installed before the bin floor is in place. The wire can always be routed wherever it needs to go once it is on the outside of the bin. If the conduit is not going to be in-line with the horizontal unloader, it may be better to wait until the floor supports and rails are in place to route the conduit so it doesn't interfere with floor support placement. Use the high temperature wire (641-046A) supplied for under the floor. Once outside the bin, any appropriate electrical control wire can be used. Pull 2 of the high temperature wires through the conduit. Connect each wire to a gearbox Hi-limit wire in the junction box on the back of the basket. Use regular wire nuts to make the connection. Refer to installation manual for dryer control used on where to connect the other end of the gearbox Hi-limit wires.

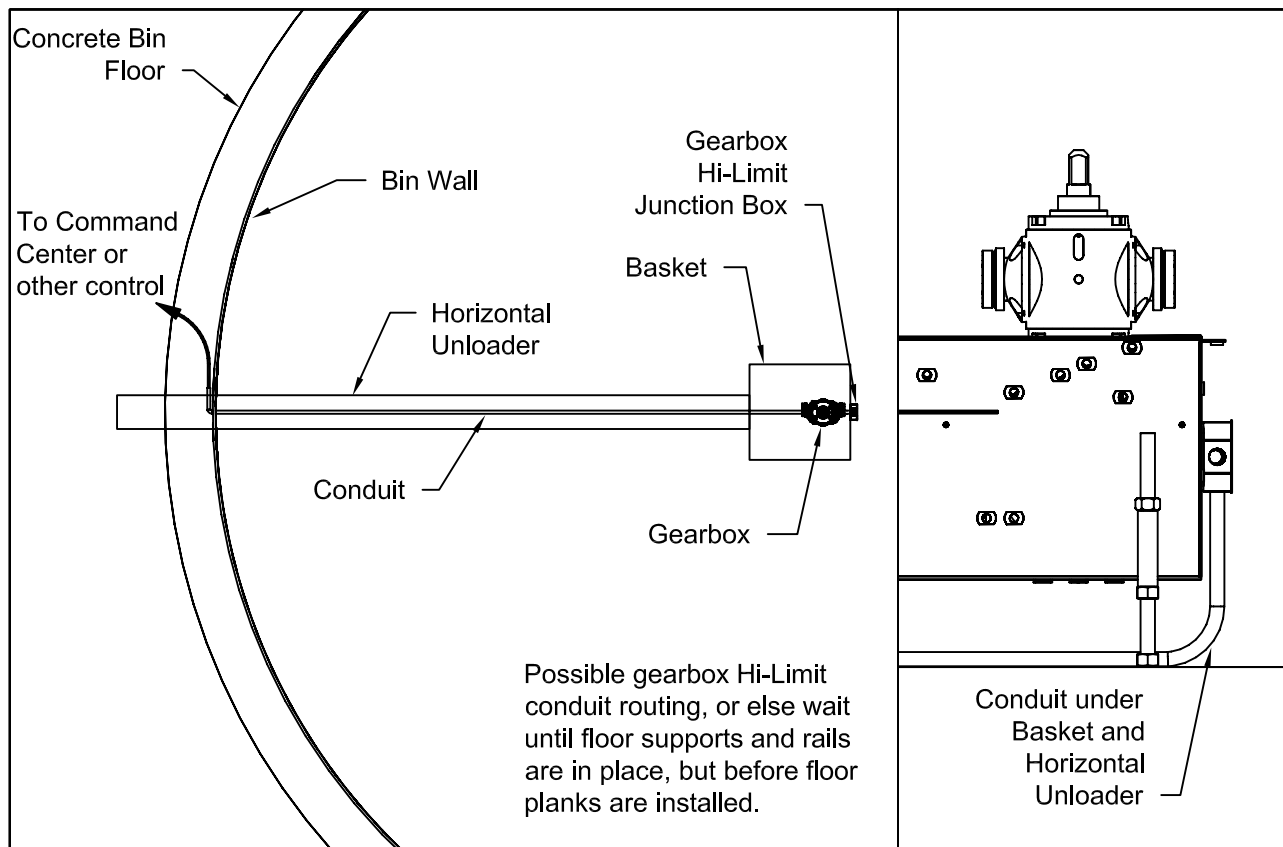

Installing Horizontal Unloader and Gearbox Basket

Step 18: Install Mounting Stand

Bolt the two halfbands around horizontal discharge tube as close to the end of the tube as possible and attach stand. Use hardware from 222-059A, Horizontal Stand Sack. Adjust height, allowing stand to support all weight. (Stand is designed to set upon a solid surface. It is recommended to dig in a footing under this stand.) Another stand is supplied in the chain and pop parts box for bins 36' and larger in diameter. Place it between the bin wall and the basket.

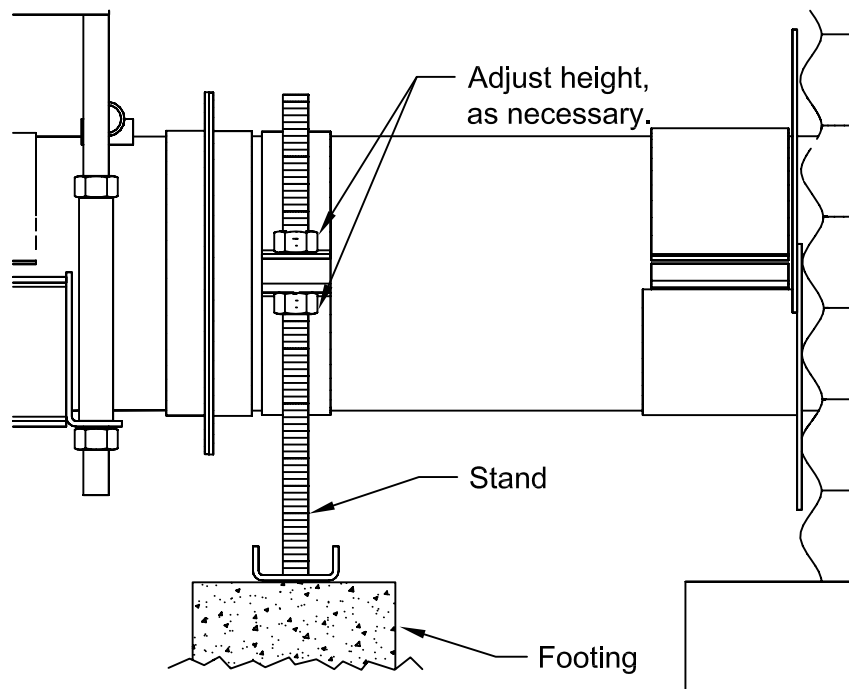
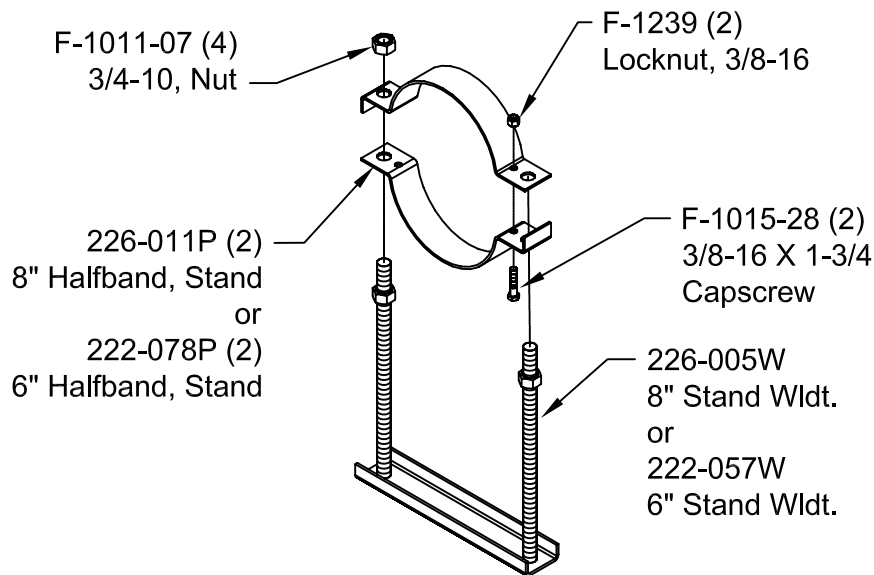

Installing Horizontal Unloader and Gearbox Basket

Step 19A: Install Idler (See 19B for mounting motor with straight down discharge. See 19C for mounting motor with outside vertical, side discharge.)

Pulley alignment becomes critical when a belt idler is used. Pulley grooves should be lined up as close as possible. If the belts pull to either side of the idler when rotating pulleys, the idler pulley should be adjusted until the belts run smoothly and perpendicular to the pulley. The idler pulley will give more of the needed belt wrap around the motor pulley if positioned closer to it than the 15" driven pulley but a minimum of 1" should be allowed between pulleys. Assembly and dimensions shown should work for most installations, but adjustments may be required.

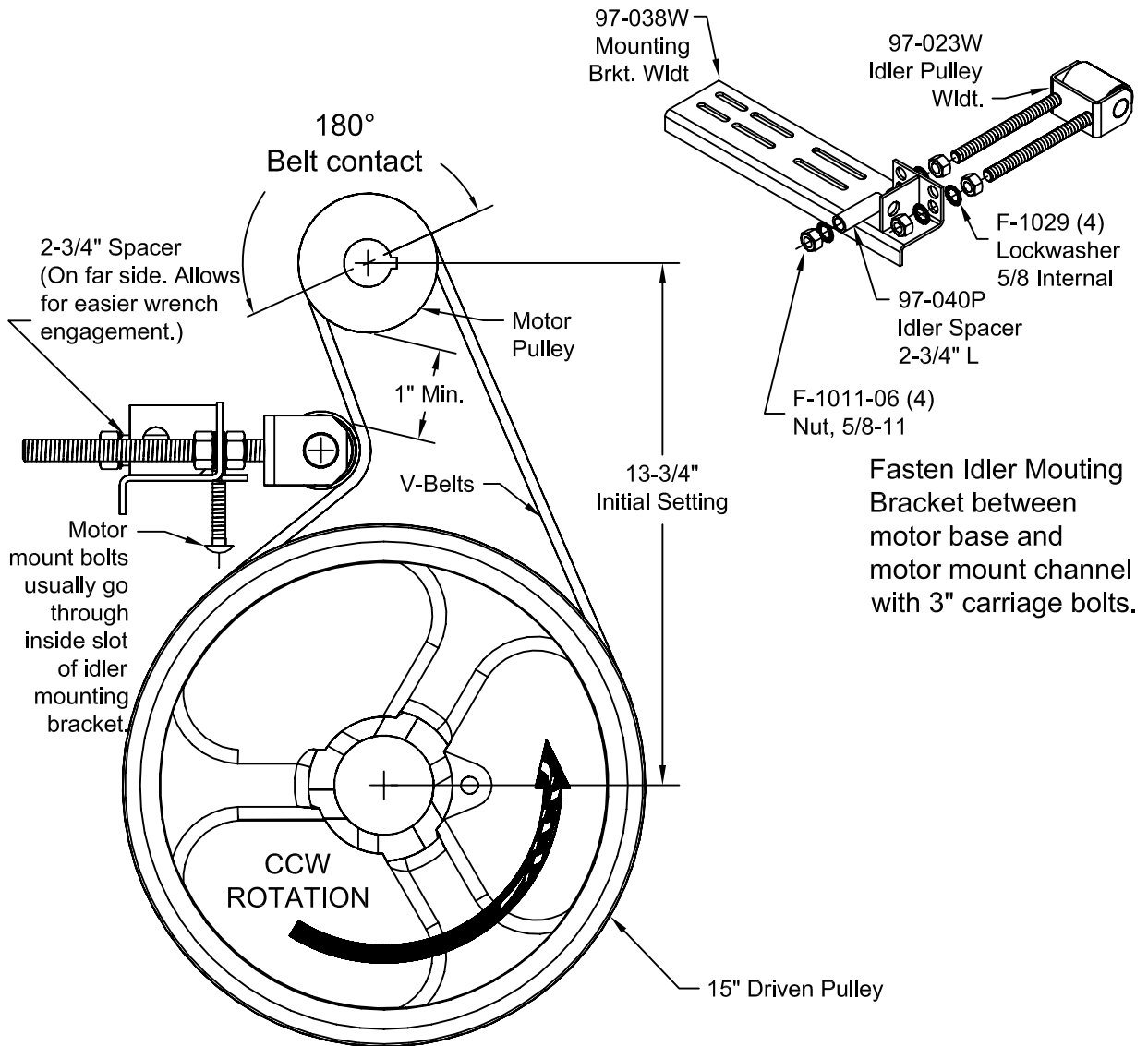

97D-001A Belt Idler Assembly, Boxed

Installing Horizontal Unloader and Gearbox Basket

Step 19B: Mounting motor (Straight down discharge).

Place wide channel on motor legs, as shown. Use hardware in sack 222-060A, horizontal motor mount. Thread nuts onto motor mount legs, slide spacer tubing over the two rear legs, install in position. Attach mounting channels, belt idler, and motor. Put on motor pulley and V-belts. Align pulleys and idler. Tighten belts. V-belts can be ordered from Shivvers using Part #D-3003-12.

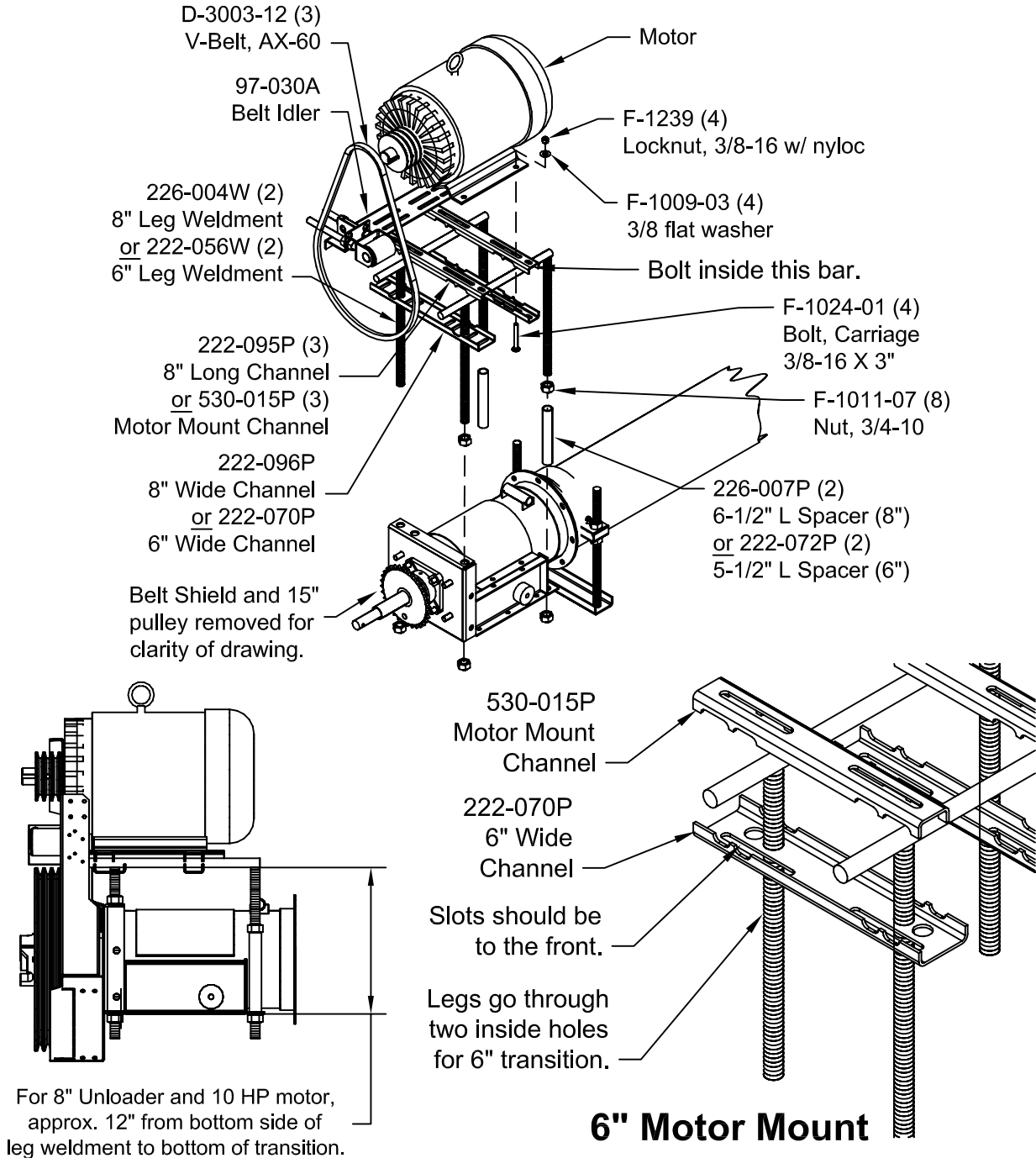

Installing Horizontal Unloader and Gearbox Basket

Step 19C: Mounting motor with outside vertical, side discharge.

Slide channel (237-032P) onto motor mount weldment (237-010W). Use hardware from vertical motor mount sack (237-015A) to attach motor mount to transition and to attach belt idler and motor to motor mount, as shown. Put on motor pulley and V-belts. Align pulleys and idler. Tighten Belts. V-Belts can be ordered through Shivvers using Part # D-3003-12.

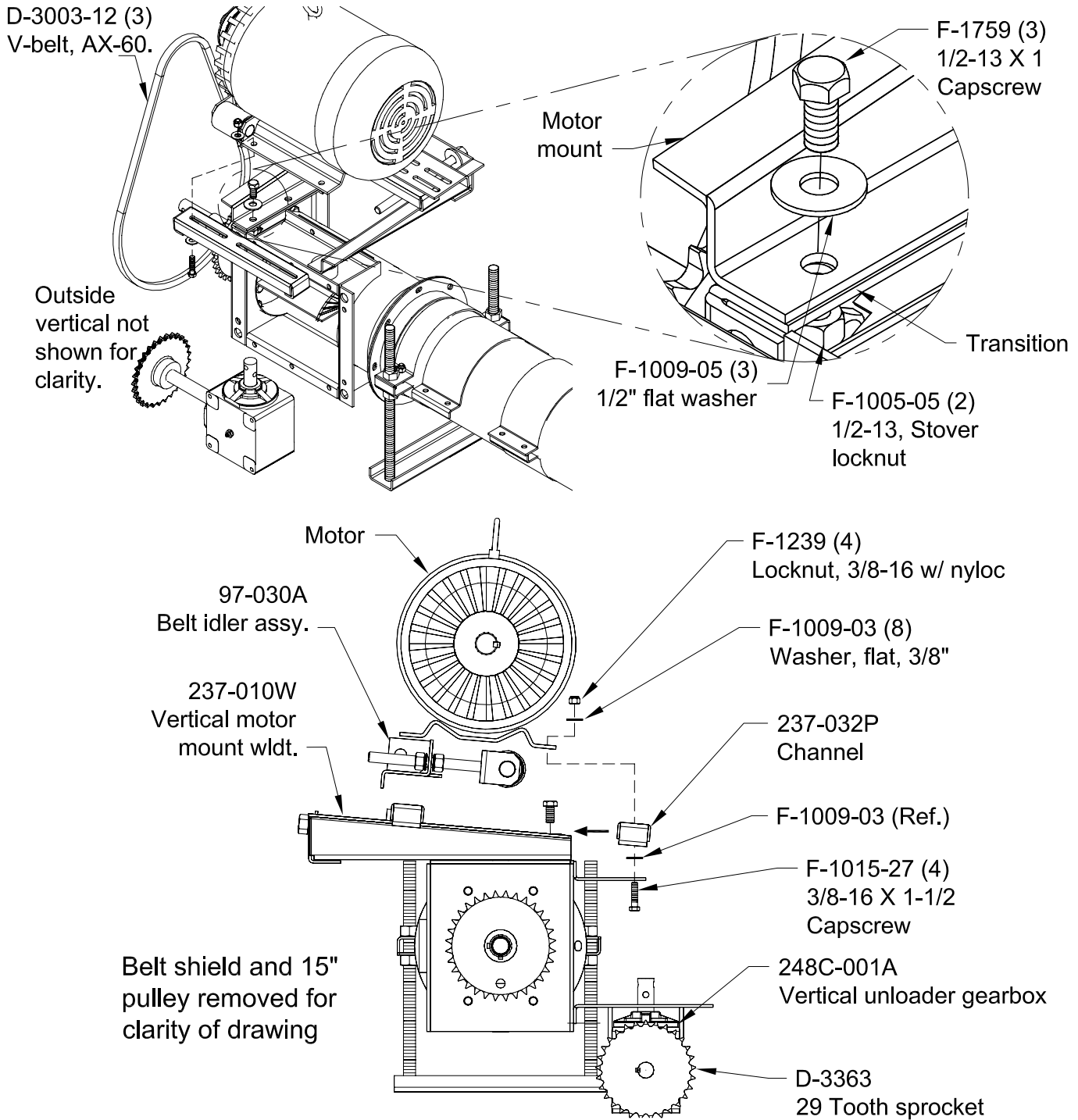

Installing Horizontal Unloader and Gearbox Basket

Step 19C: Continued

Follow instructions from P-11875 supplied with the belt shield for cutting out belt shield back and installing sprocket shield for bottom drive outside vertical chain. Align sprockets and install chain idler and chain for outside vertical. Put on sprocket shield cover.

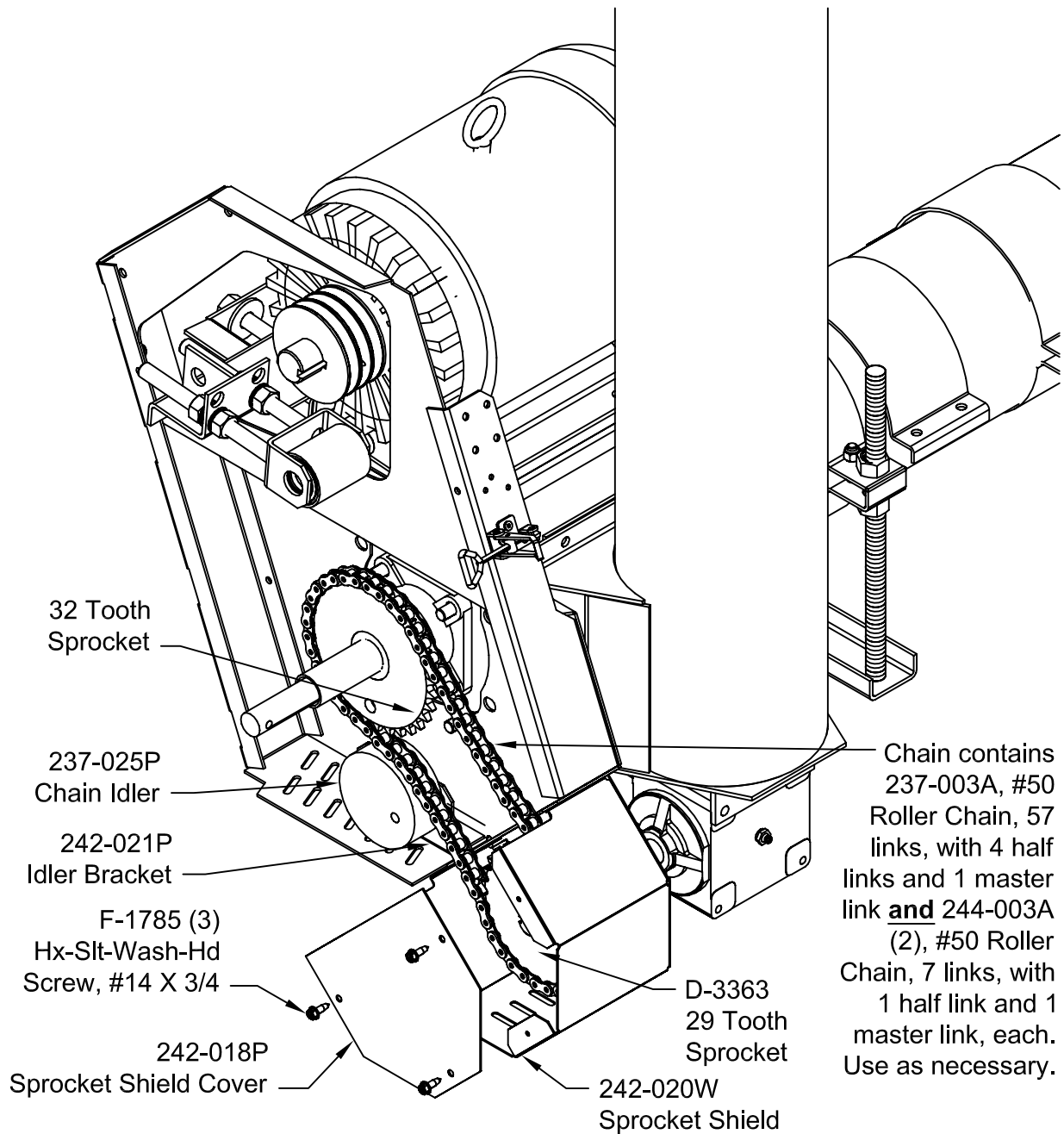

Installing Horizontal Unloader and Gearbox Basket

Step 20A:

Attach belt shield motor guard (225-087P) to belt shield back, as shown, using hardware from belt shield hardware sack.

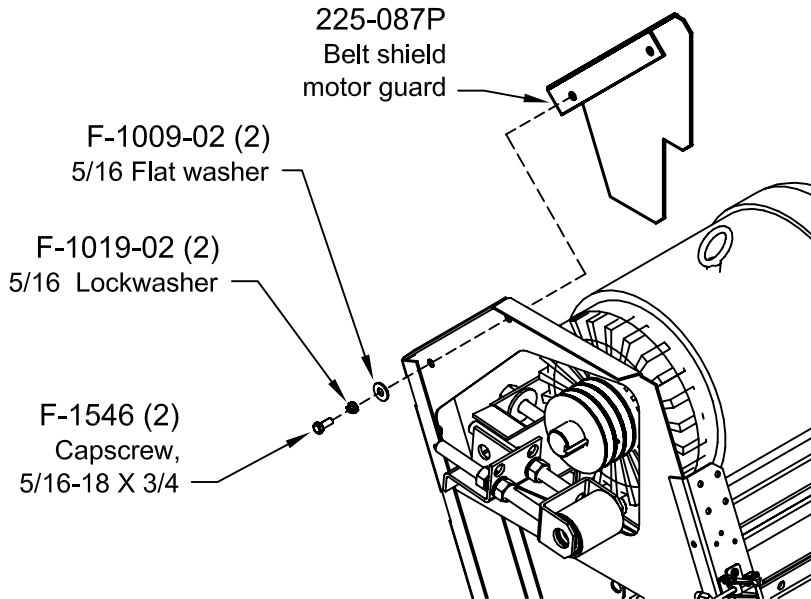

Step 20B:

Attach latch striker from H-2412 kit to belt shield cover (225-080A) into top holes for installation without an outside vertical or bottom holes for installations with an outside vertical, using hardware provided with kit. Install belt shield cover onto belt shield back, as shown.

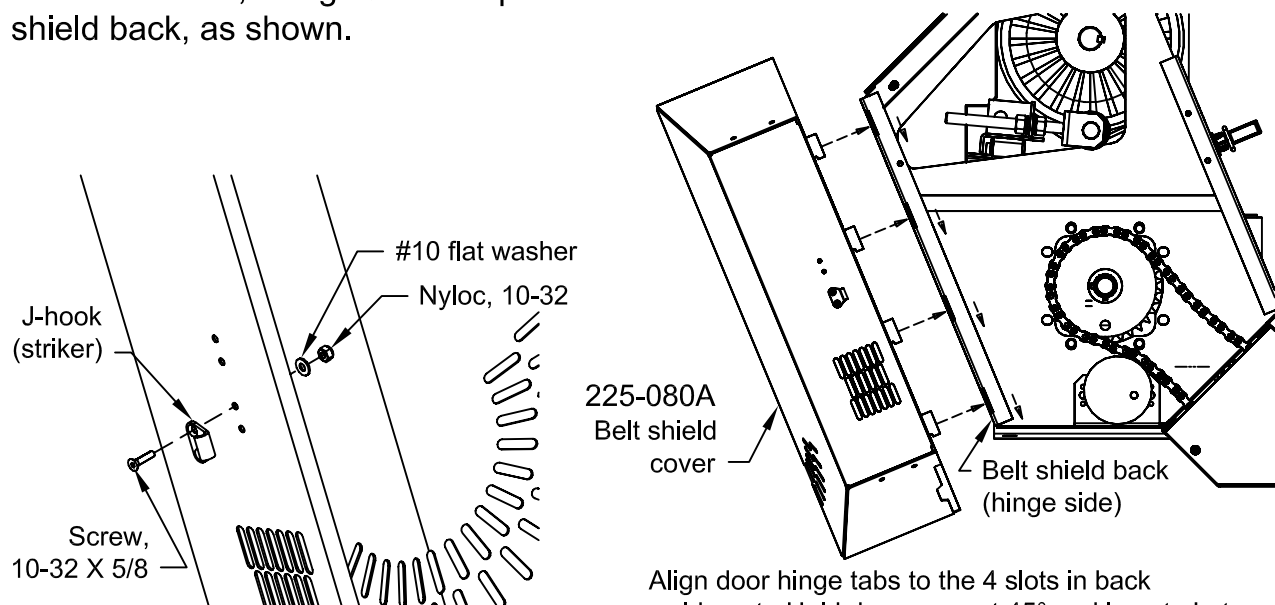

Align door hinge tabs to the 4 slots in back weldment. Hold door open at 45° and insert. Let weight of door go down to lock hinges in position.

Installing Horizontal Unloader and Gearbox Basket

Step 21:

Follow instructions provided with floor and supports to install perforated drying floor.

Step 22:

Make sure enough of the floor planks are cut out to provide access to Gearbox Hi-Limit junction box and basket support legs. **This would be a good time to check that the gearbox is square to the floor using the 423-351-001A Gearbox Laser Mount Kit.**

Bolt the end plates to the basket with 3/8" hex socket button head capscrews from 222-085A basket sack. Drill required holes to pop rivet end plates and basket sides to floor planks.

NOTE: 3/8" hex socket button head bolts must be used for sweep auger clearance.

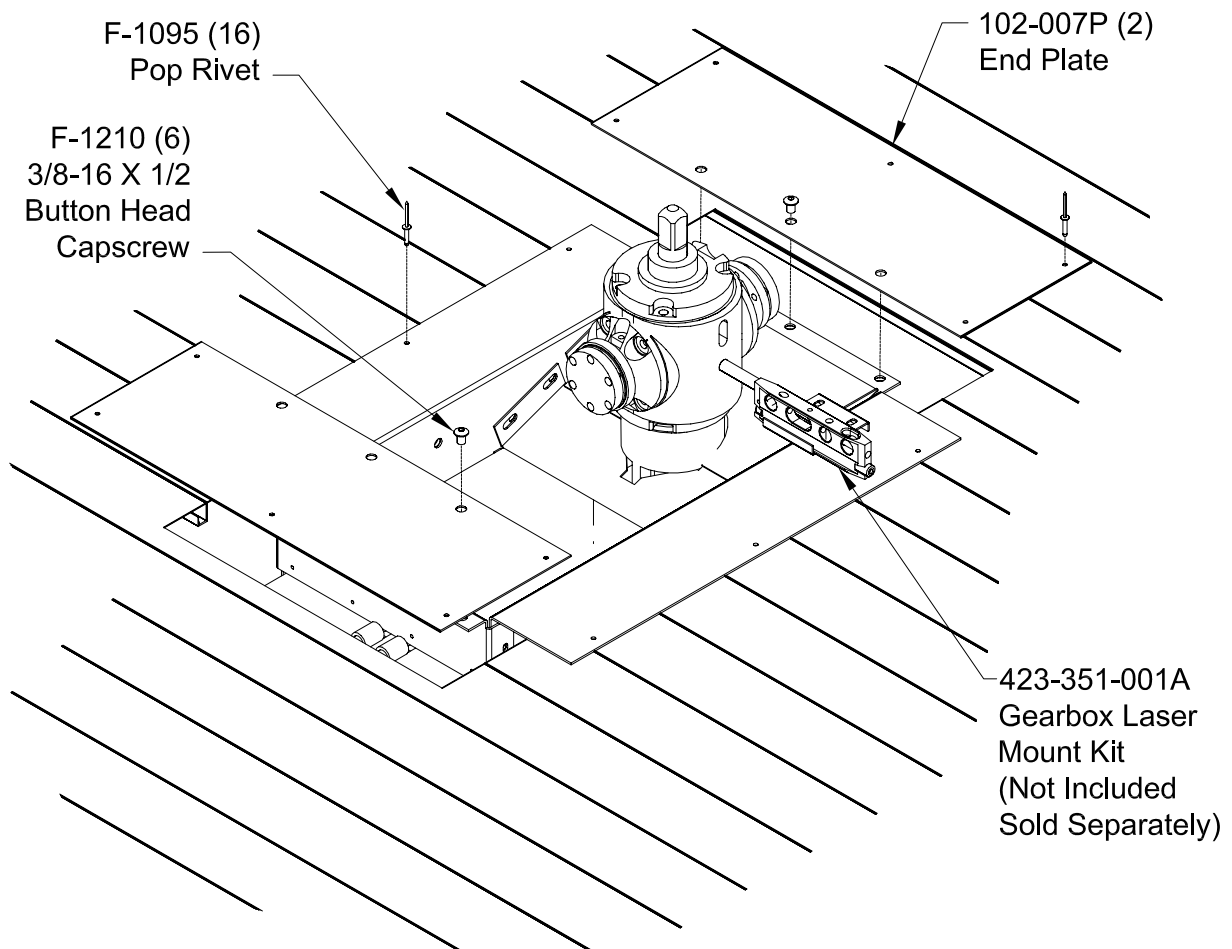

Tapered Sweep and Wear Track Installation

Step 1:

- a. Remove caplugs from tapered sweep's coupler. Remove all debris from the tapered sweep's coupler and outside surfaces of the gearbox base and flange.
- b. Pack the inside of the tapered sweep's coupler and coat the outside of the gearbox's base and flange with our recommended high temperature-rated grease, Chevron Ulti-Plex Synthetic Grease EP or equivalent. (Shivvers # C-6188 (14oz Tube).
CAUTION: USE ONLY THIS GREASE. Other greases may harden in the coupler, causing sweeps to break.

Step 2:

Bolt the tapered sweep auger(s) to the gearbox as follows: See Figure A

- a. 3/8-16 sockethead capscrew (F-2158) and locknuts (F-1005-03) are provided in the decal package. This bolt and nut must be used.
- b. Position the sweep's coupler onto the output shaft.
- c. Insert bolts into sweep's coupler, through the output shaft, and start the threads into the flange, then start a nut onto the end of each bolt.
- d. Tighten the bolts down to about 36-40 ft/lbs.
- e. With a hex wrench on the head of the bolt, tighten the nut, in effect double-nutting it with the flange. The bolt should have threads seen on the outside of the nut. As added protection from loosening, it is recommended that you hit the thread next to the nut with a punch to deform the thread, locking it in place.
- f. Repeat the above process to install all tapered sweeps as required.

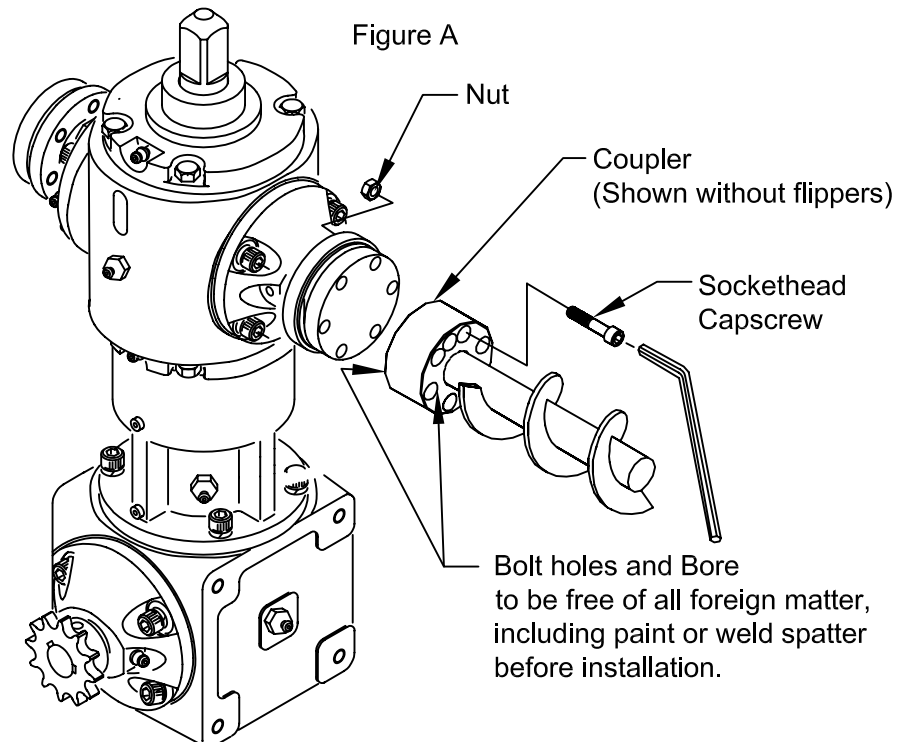

It is recommended that these bolts and nuts not be re-used. See your dealer or Shivvers for replacement of hardware sack #635-014A for 3/8 hardware.

Tapered Sweep and Wear Track Installation

Step 3:

There should be flex in the coupling after the sweep auger is bolted to the gearbox. Check to make sure the sweep can be lifted a minimum of 6" at the outer end of bin without bending the sweep auger shaft. Check this in at least 4 places around the bin, especially in-line with and perpendicular to the horizontal unloader. If the amount of flex is not uniform around the bin, the basket legs will have to be adjusted.

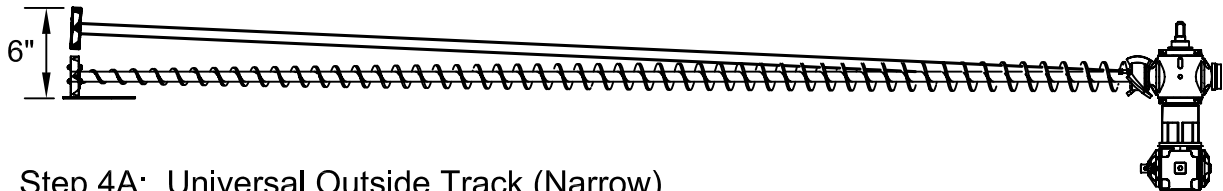

Step 4A: Universal Outside Track (Narrow)



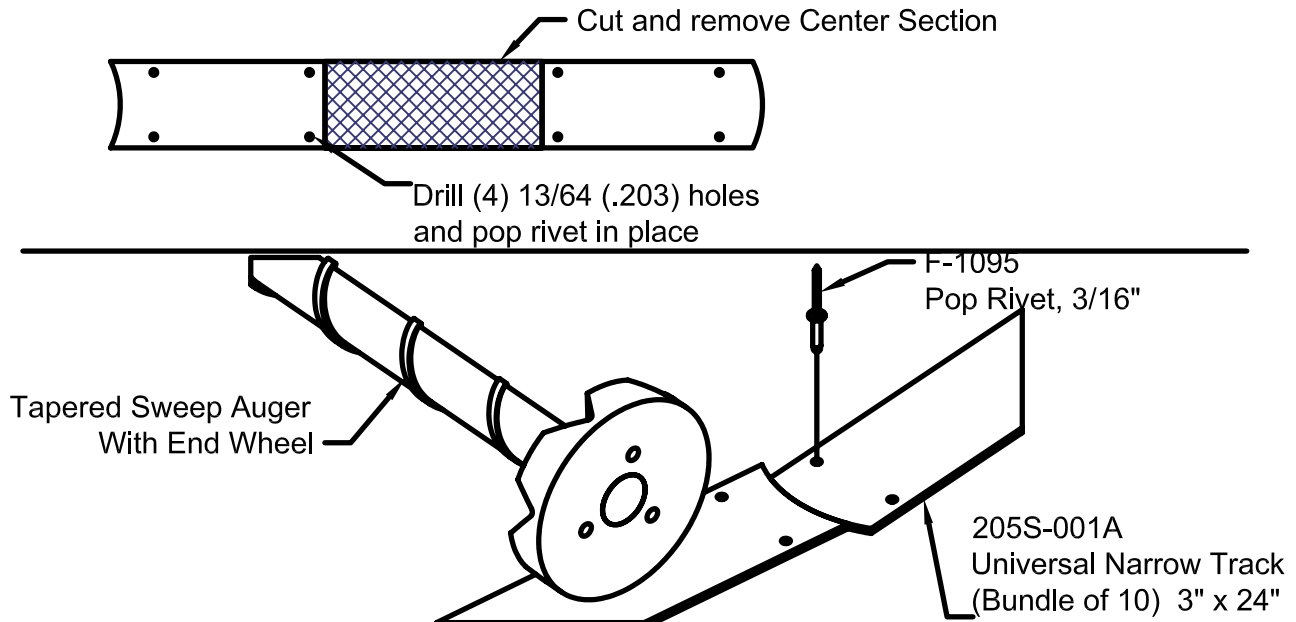

Bin diameters 29' - 33' do not normally use an outside track. For all other bin sizes or for all sweep augers with an outside wheel, install an outside track. **Lay the track sections so that ends butt up against each other (no cracks between sections), flush and smooth (one end not higher than another), with the sweep auger wheel riding the center of each end.** As each section is laid in place, move the tapered sweep along the track to insure that curvature and location are correct, then fasten securely with 3/16" pop rivets. Pop rivets are provided in the 450X-001A series Chain and Pop Rivets Box. Drill additional holes and pop rivet track down, as necessary, to insure a firm and smooth track. Do not use self-drilling screws. They will loosen with time. **Do not allow the wheel to run over a pop rivet head.** The last section of track usually must be trimmed to size. To trim, remove a straight section out of the center of the track, as shown below. Drill 13/64" (.203") holes and pop rivet both ends down.

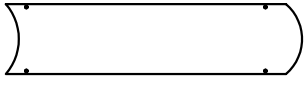

Tapered Sweep and Wear Track Installation

Step 4B: Universal Inset Track (Wide)

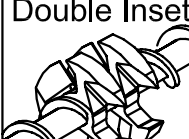
The tapered sweep auger for bins 29' diameter and over have an inset wheel that moves along a wide wear track mounted on the bin floor. These track sections must be laid so as to form a smooth, firm path along the bin floor on which the tapered sweep auger can move. **Lay the track sections so that the ends butt up against each other (no cracks between sections), flush and smooth (one end not higher than another), with the inset wheel riding the center of each end.** As each section of track is placed on the floor, move the tapered sweep along the track section to insure that the inset wheel will be centered as it runs along the track. After checking the location, mount the track with 3/16" pop rivets. Drill additional holes and pop rivet track down, as necessary, to insure a firm, smooth track. Do not use self drilling screws. They can loosen with time. **Do not allow the wheel to run over a pop rivet head.** The last section of track usually must be trimmed to size. To trim, remove a straight section out of the center of the track. Drill 13/64" (.203") holes and pop rivet both ends down. See illustration from Step 4A on the previous page.

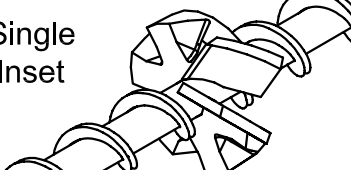
Track Bundle Part #	Track Style & Dimensions	Inset Wheel Location From		
		Inset Wheel Style	Inset Wheel Style	
205R -001A 5 Pieces Per Bundle (205-014P) (individual)	 Universal Wide Track 6" x 24"	Gearbox Base	Double Inset	Bolt-On Inset
		9'-7"		
		11'-10"		
		12'-7/8"	Single Inset	

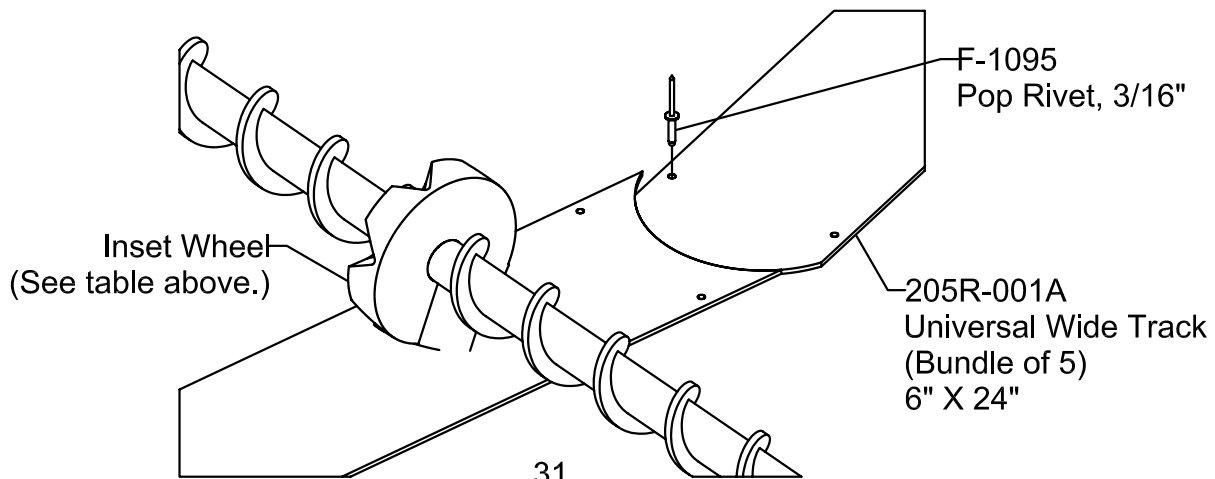

Center Vertical Installation

Step 1: Center Vertical Chains

Shivvers recommends using scaffolding to install the Center Vertical Chains. Measure along the bin wall to the height of your center vertical tube when installed on gearbox (16'9", 17'9", 18'5", or 20'3"). The chains should either go straight across from the bottom plate of the center vertical or down slightly. They should never be higher than the center vertical. Fasten the long or short chains (your choice) from the chain and pop rivet parts box to the bin sidewall or roof using the mounting brackets. (See Page 37) Follow the directions in P-12053. Place another mounting bracket and chain directly across the bin at the same height. Then space two more equi-distant between these on each side of the bin, for a total of six chains. Place 6 chains at the bottom plate of the spreader assembly with bolts, nuts, washers and spacers from the chain and pop rivet box as shown below.

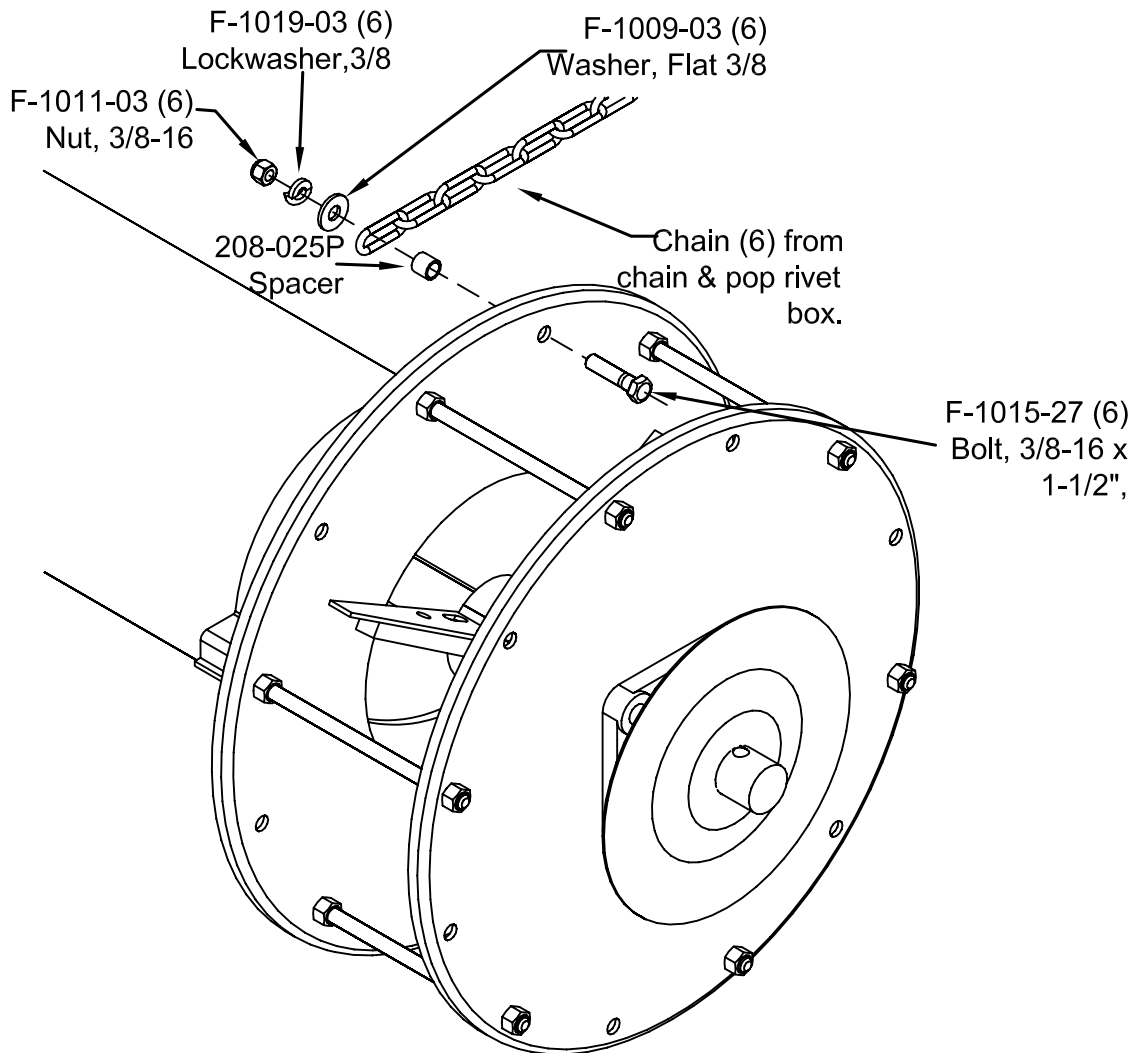

Center Vertical Installation

Step 2: Recirculation Spreader Fins

Bolt spreader fins on the spreader wheel of the center vertical tube as recommended for bin diameter. Fins should be 1/8 - 3/16" above center vertical bottom plate. Make sure the fins, not the spreader wheel, contact the grain.

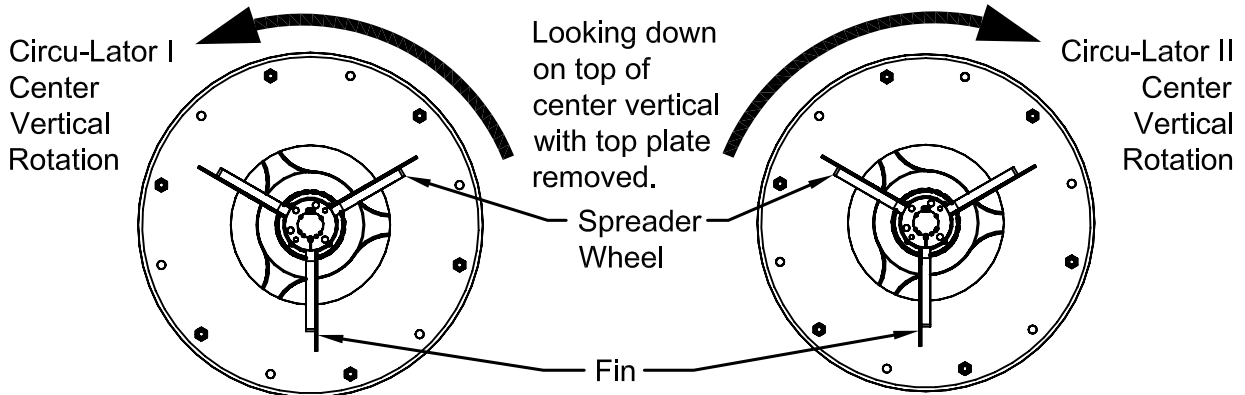

17'7" - 18'7" Dia. bins - No additional spreader fins required. Built in fins are adequate.

21'0" - 22'0" Dia. bins - Small tapered spreader fins (10A-047P) should be installed.

23'6" - 24'9" Dia. bins - 4-3/4" X 1-1/2" rectangular spreader fins (10A-048P) should be installed.

26'5" - 42'0" Dia. bins - Large spreader fins with elevating angles (10B-049W or 10-080W) should be installed.

NOTE:

Save the extra fins. It may be necessary to use them to adjust for more optimum spread. They may be used in any combination.

10A-047P
Small tapered fin for Circ I or Circ II

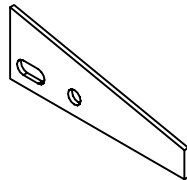

222-083A
Spreader fin sack for Circ. I (1 sweep)

10B-049W
Large fin with elevating angle for Circ I only

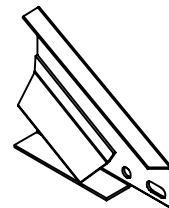

10A-048P
Medium rectangular fin for Circ I or Circ II

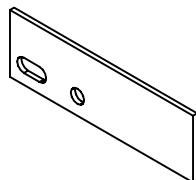

226D-014A
Spreader fin sack for Circ. II (2 sweeps)

10-080W
Large fin with elevating angle for Circ II only

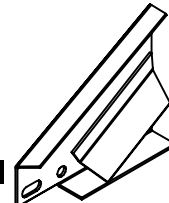

Center Vertical Installation

Step 3: (Optional) Continuous flow boot and moisture sensor can be mounted now or after center vertical is in place.

Cut hole in center vertical tube for continuous flow auger boot(s), following instructions (P-8969-P) included with boot or on decal P-11617 on the high angle boot. Cut hole for moisture sensor (if used) following instructions (P-11227) included with sensor. Cut center vertical fluting for moisture sensor. Hole and fluting are pre-cut for WSCV. For accurate moisture readings, it is better to cut out more fluting than it is to cut too little.

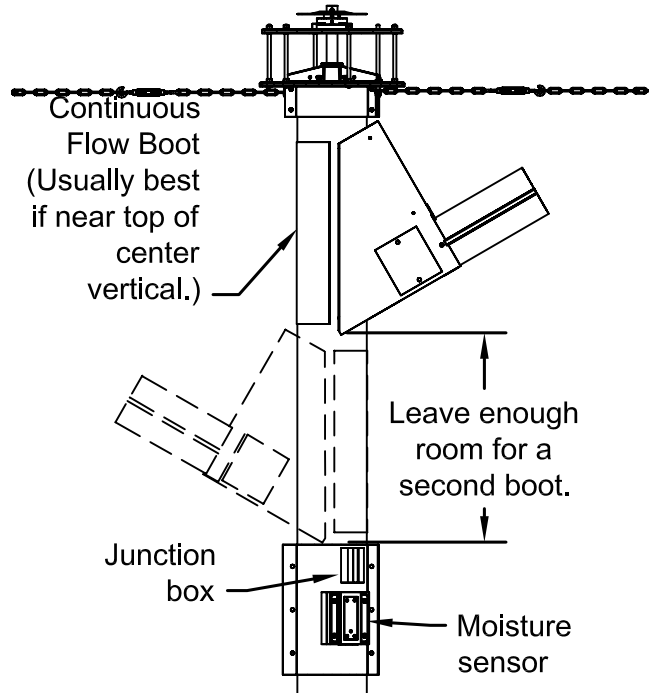

Step 4:

Place the spider wheel on the gearbox. Make sure it is seated all the way down on the gearbox. The top of spider wheel should be flush with flats of gearbox square shaft. Elevate center vertical assembly and lower it onto spider wheel, being sure square coupling of auger connects with square shaft of gearbox. Be sure cone bottom rests on spider wheel. It may be necessary to pound the bottom of the cone in, especially where the weld seam is.

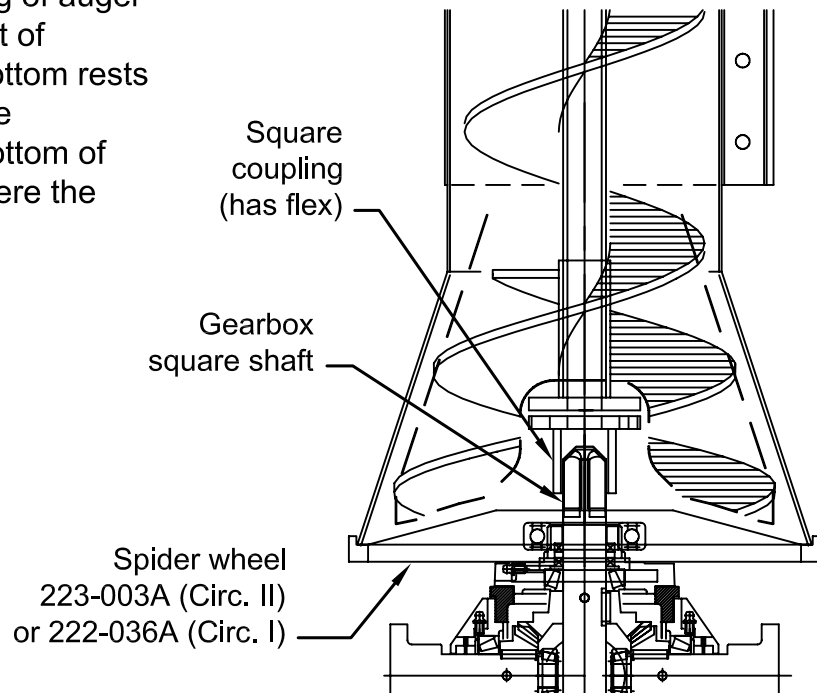

Center Vertical Installation

Step 5:

Connect long chains to short chain with turnbuckles. Using a good level, plumb the center vertical tube vertically in all directions by adjusting turnbuckles.

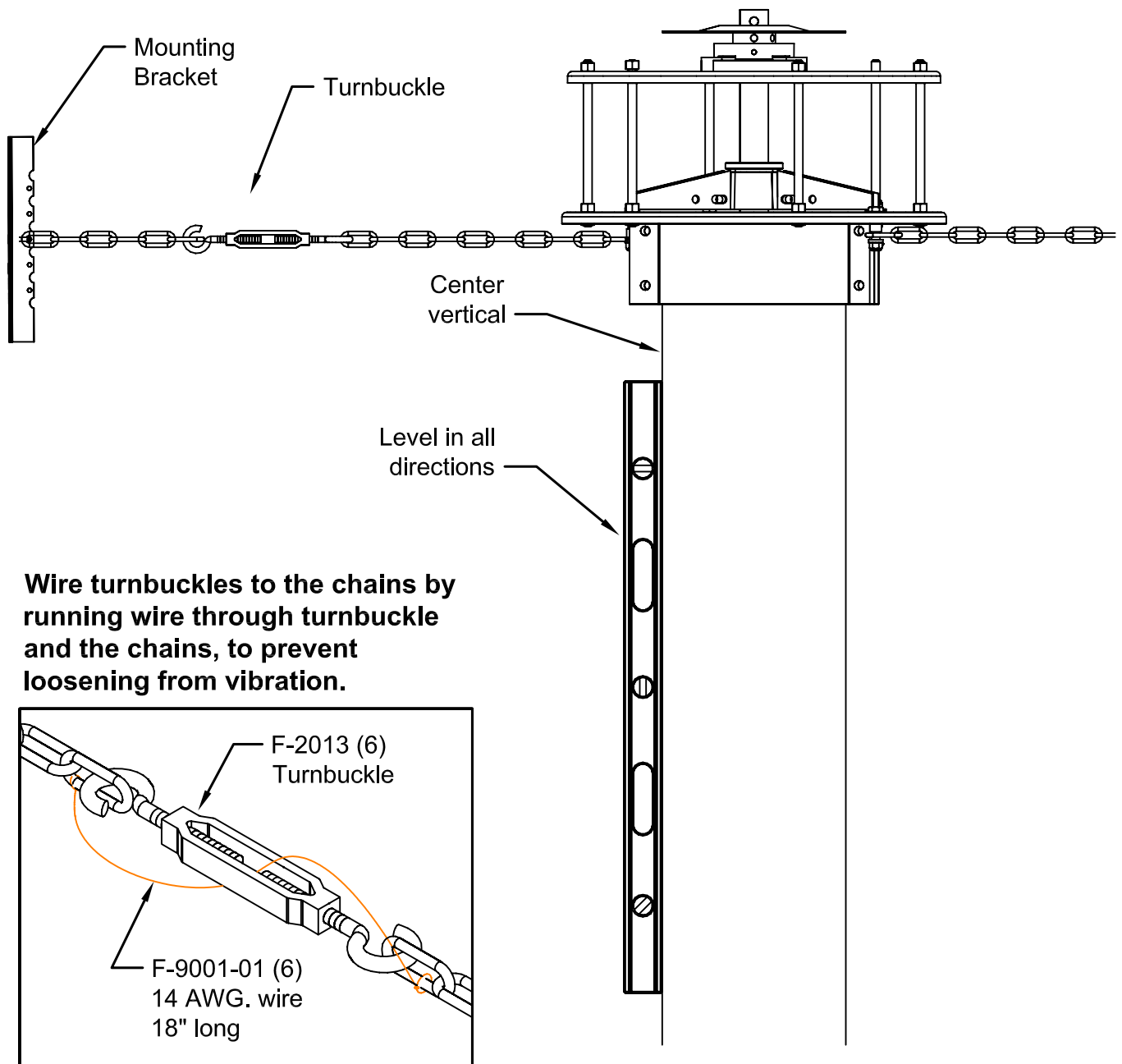

Center Vertical Installation

Step 6: Check tolerances on 6" and 8" center vertical augers

1. All dimensions must be checked with center vertical auger in vertical position and resting squarely on spider wheel.

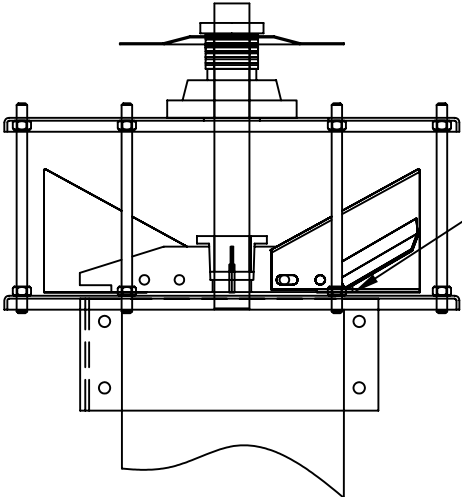

2. In vertical position keep bolted on spreader fins between 1/8" and 3/16" above the bottom plate.

3. Tip of fingers (first 3/4" from outside) must have 3/8" to 5/8" clearance. 1/2" is ideal between bottom of tip and top of spider wheel. Clearance may be larger than 5/8" at the remainder of the lower edge (inside the tips).

3/8" min.
5/8" max.

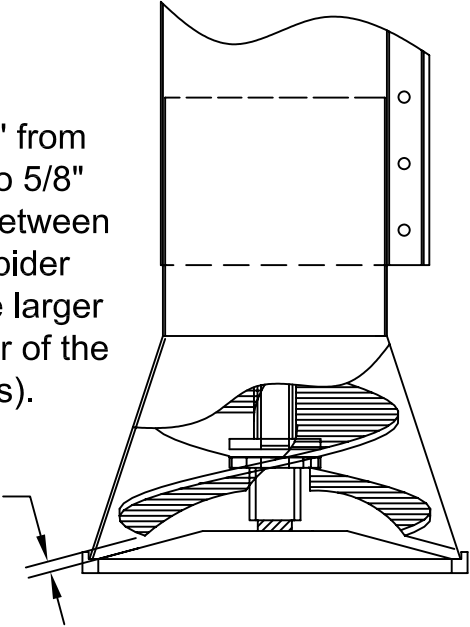

Installing Safety Decals and Locks

Before applying decals, make sure the mounting surfaces are clean (not oily) and dry.

P-10811 - Field Installed.

1). ON MAIN POWER DISCONNECT SWITCH BOX

Put it only on the disconnect that shuts power off to the complete drying system (every motor, fan, and burner). Don't put it on any other disconnect.

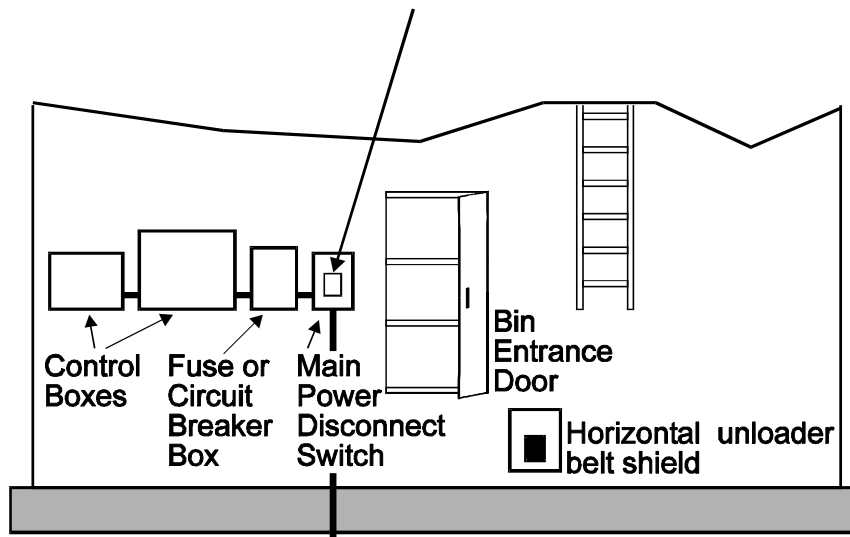

Installing Safety Decals and Locks

P-11035 - Field Installed.

- 1). OUTSIDE OF OUTER BIN DOOR ENTRANCE
- 2). OUTSIDE OF INNER BIN DOOR ENTRANCE
- 3). NEAR MANHOLE ENTRANCE

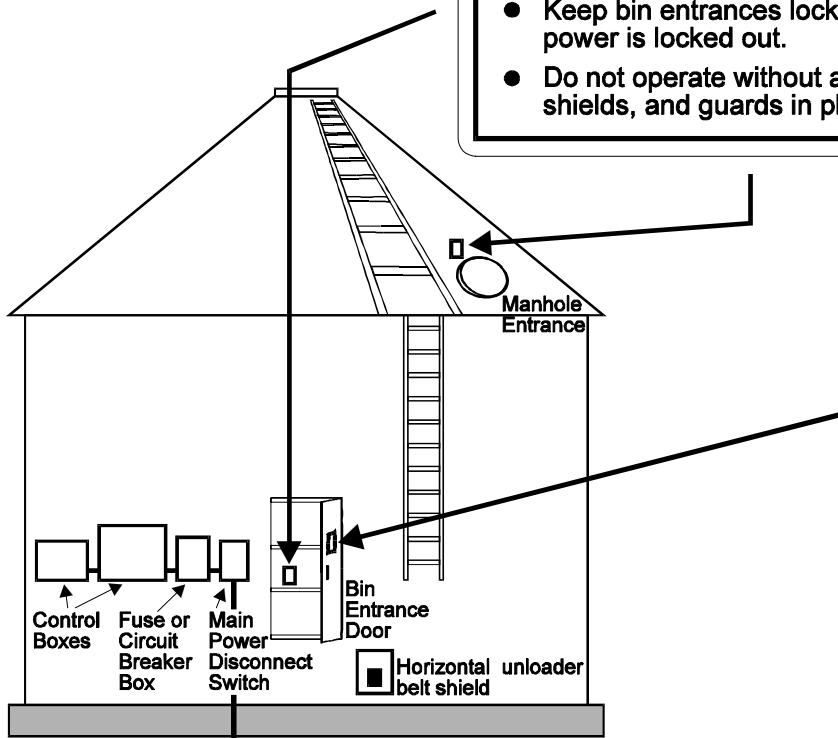
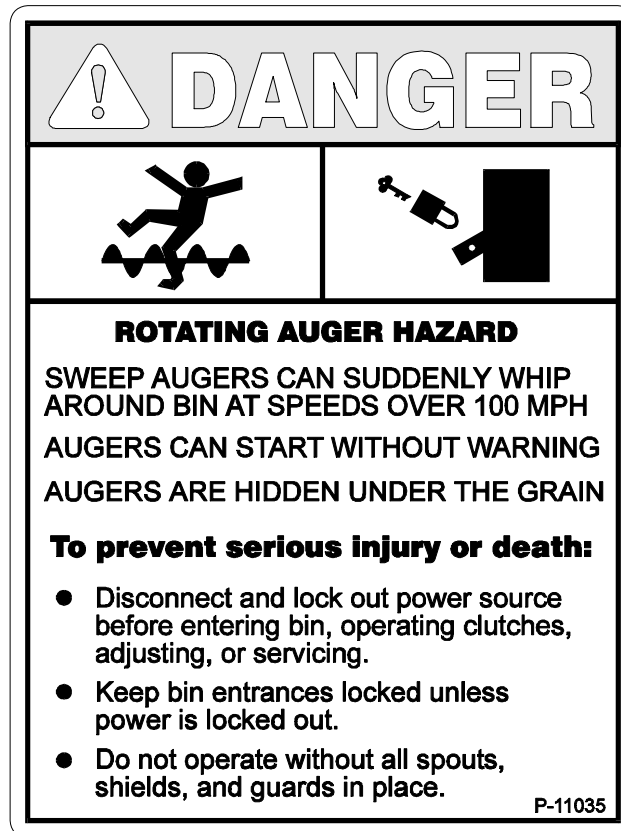

Installing Safety Decals and Locks

P-10125 - Field Installed.

- 1). INSIDE OF OUTER BIN DOOR ENTRANCE ON ALL BINS
- 2). NEAR MANHOLE ENTRANCE ON ALL BINS

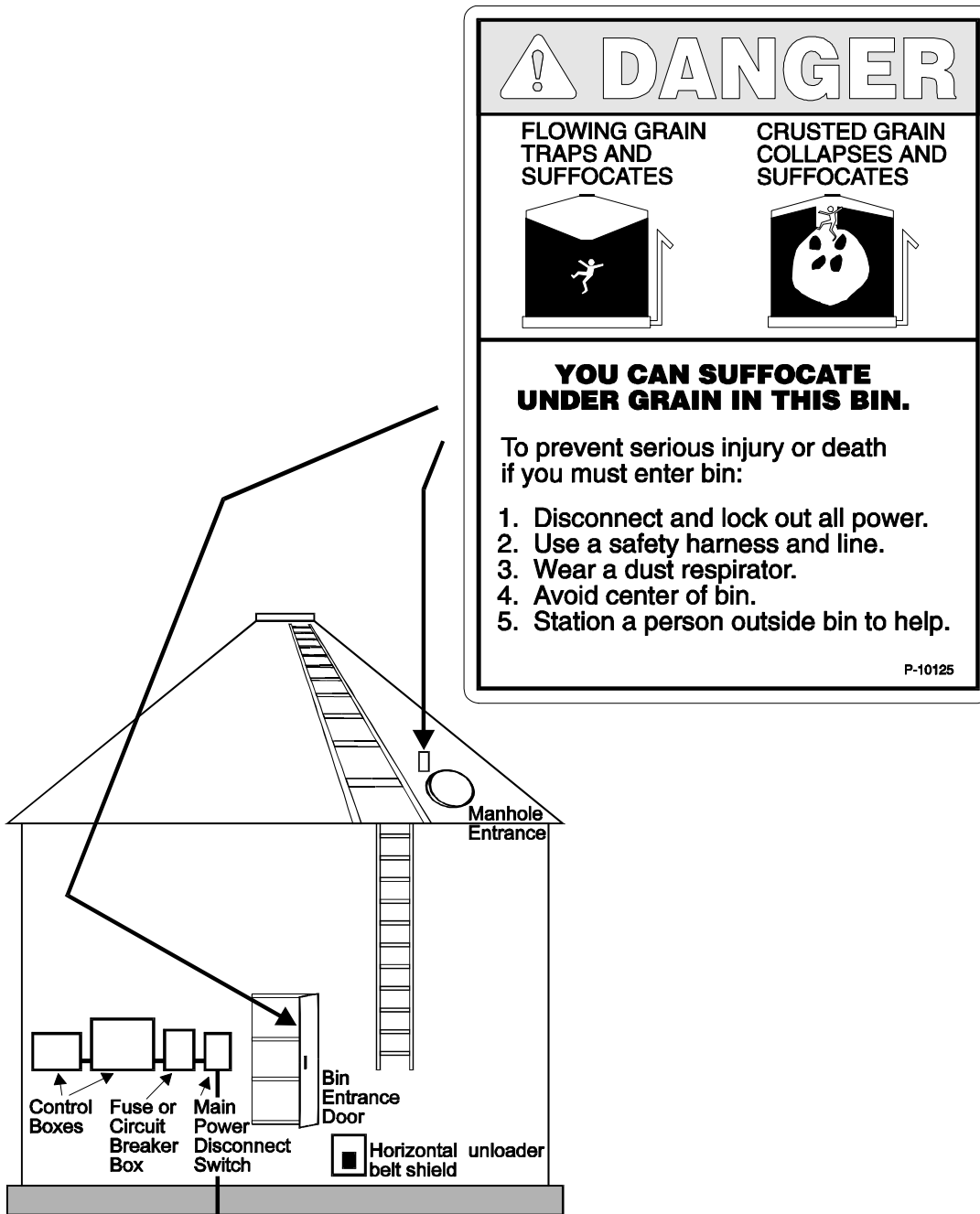

Installing Safety Decals and Locks

Two 632-191A (Safety Lock Kits) are provided with each Shivvers dryer. This kit includes an H-2055 Padlock, P-11158 Self Laminating Lockout Decal, and hardware which will allow locking of any bin entrance point.

Make sure a grain drying main disconnect box is installed and that this padlock works on it. If it doesn't, find one that will or contact Shivvers Manufacturing, Inc. for assistance. Leave the power locked off.

If the dryer bin is not equipped with a lockable entry door in good condition, attach one end of the cable assembly to the bin side wall. Use an existing bolt, or use the hardware provided. Attach the staple plate to the bin entrance door within reach of the opposite end of the cable assembly. Use the hardware provided, or weld the staple plate securely to the door.

Install a safety lock kit on the manhole cover also. If there are more than two entrances on the bin, order additional Safety Lock Kits. Try the locks and make sure entrance to the bin is denied.

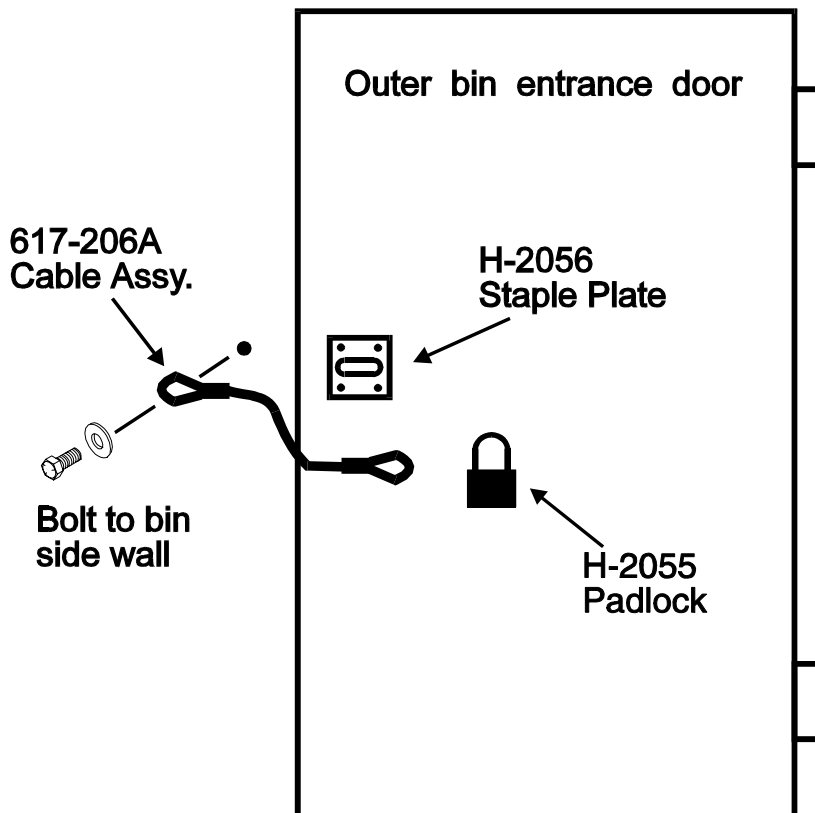

Installing Safety Decals and Locks

P-11158 - Field Installed.

Write the operator's name on the P-11158 decal. Cover the printing with the clear laminate, then apply the decal to the padlock. These locks can then be used to lock out power sources when working on the drying equipment. Keep the bin entrances locked when operating the equipment to prevent unauthorized access to potential dangers. The locks will also remind you to disconnect and lock out power sources before entering the bin.

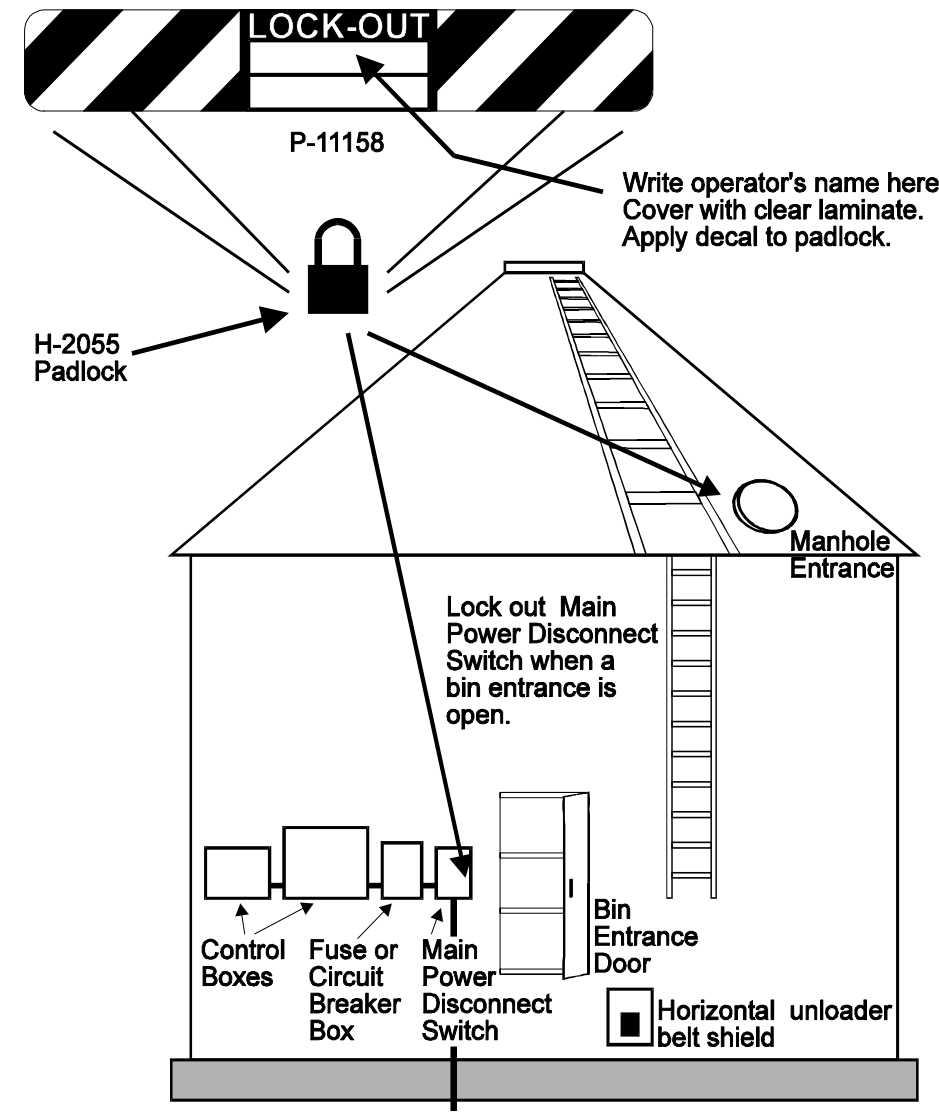

Circu-lator Installation Final Check

- 1□ Check that all joints are level and solid, without cracks, in the tapered sweep wheel track, and that the track is pop riveted, not screwed, down.
- 2□ Make certain the tapered sweep wheel(s) do not hit pop rivets in the track.
- 3□ Make sure the tapered sweep augers have "flex" in the coupling by lifting the outer end in several locations around the bin.
- 4□ Make sure gearbox is square with the floor. Use gearbox laser kit.
- 5□ Check that the chain coupler master link is installed correctly.
- 6□ Make sure there is 1/8 - 1/4" gap between the horizontal flight weldment tube and the sprocket on 1" drive shaft where O-ring is located, inside the basket.
- 7□ Make sure the Center Vertical is plumb.
- 8□ Make sure the spreader wheel has fins installed as needed and extra fins are given to the operator.
- 9□ Make sure center vertical chain turnbuckles are wired to prevent loosening.
- 10□ Check pickup fingers for proper clearance and engagement. Make sure the cone is all the way into the spider wheel.
- 11□ Make sure the 3-jaw clutch and unloading pin will operate correctly.
- 12□ Check belt alignment and tension. Make sure belts don't try to roll over.
- 13□ Check slide gates for proper operation and leave them in the closed position.
- 14□ Make sure all Safety Decals are in place as shown in P-10001 Operator's Safety Manual. Make sure all guards are in place.
- 15□ Make sure the Safety Lock Kits (632-101A) are installed as shown in this manual and P-10001 Operator's Safety Manual, and P-11175 Instructions. Either the bin entrances or the power should be locked off.
- 16□ Make sure the operator has the Operator's Safety Manual, Operating manuals for each piece of equipment installed, and Safety Lock keys. Make sure they understand how to operate each piece of equipment safely.