

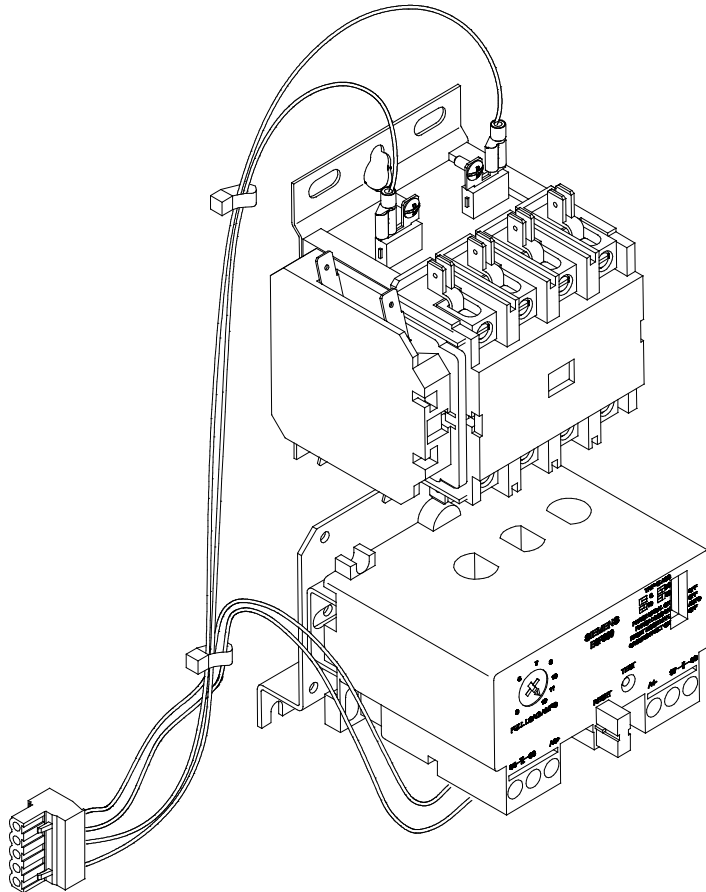

STARTER INSTALLATION INSTRUCTIONS

FOR STARTER MODELS
641 X, Y, Z - 001A

Replaces obsolete models 641 C, D, E, F, Q -001A



SHIVERS MANUFACTURING, INC.
CORYDON, IOWA USA
Ph. (641) 872-1005 ** Fax (641) 872-1593
www.shivers.com

P-11349
Dec 10, 2020
REV. E

INTRODUCTION

In 2011, Siemens/Furnas made their line of definite purpose starters obsolete. Shivvers attempted to find suitable drop-in replacements, but was unable to find exact equivalents. Older panels might require some field adjustments in order to install the new starters. Review the part numbers carefully, as they have changed some. In general, the contactor portion has been changed to a Square D brand. The overload for single phase was changed to a Siemens stand alone bi-metallic overload (E-6515), similar to what was used in the past. In the middle of 2020, Siemens made the bi-metallic overload obsolete.

For three phase and now single phase, the overload has changed to a Siemens electronic overload. The motor leads pass through holes in the overload to sense current draw. It has a dial setting which can be adjusted for motor full load amps, and does not require heater strips. For single phase motors, one motor lead will have to loop through the 3rd hole in the electronic overload. Three sizes are currently offered, 3-12 Amps (E-6516), 10-40 Amps (E-6517), and 25-100 Amps (E-6518).

SAFETY

The installer of this equipment must assume the responsibility for his own safety, and that of those working around him. He must also make sure that the equipment is installed as shown in this manual.

If any items covered in this manual are not completely understood, or there is a concern with the safety of this product, contact Shivers at the address shown on the front page.



**TAKE NOTE ANYTIME THIS SYMBOL APPEARS.
YOUR SAFETY, AND THAT OF PERSONS
AROUND YOU IS AT STAKE.**

ALL ELECTRICAL WIRING SHALL BE INSTALLED IN COMPLIANCE WITH THE LATEST EDITION OF THE ANSI/NFPA STANDARD 70, NATIONAL ELECTRICAL CODE, AS A MINIMUM REQUIREMENT, AND IN COMPLIANCE WITH LOCAL WIRING CODES AS APPLICABLE.

WIRING MUST BE DONE BY A COMPETENT ELECTRICIAN. A LICENSED ELECTRICIAN IS RECOMMENDED, AND MUST BE USED WHEN REQUIRED BY LOCAL OR STATE STATUTES.

SINGLE & THREE PHASE

| Shivvers Part # | Contactor # of Poles | Overload Only Part # | Overload Amp Setting | 3 PH MOTOR HP | | | 1 PH Motor HP 240V |
|---------------------------------|----------------------|----------------------|----------------------|---------------|------|------|--------------------|
| | | | | 208/230V | 460V | 575V | |
| 641Y-001A (40 Amp Contactor) | 4 | E-6516 | 3-12 | 2 | 2 | 3 | 2 |
| | | | | 3 | 3 | 5 | |
| | | | | | 5 | 7.5 | |
| | | | | | | 10 | |
| 641X-001A (40 Amp Contactor) | 4 | E-6517 | 10-40 | 5 | 7.5 | 15 | 3 |
| | | | | 7.5 | 10 | | 5 |
| | | | | 10 | 15 | | |
| 641Z-001A (60 Amp Contactor) | 3 | E-6518 | 25-100 | 15 | | | 7.5 |
| | | | | | | | 10 |
| | | | | | | | 12.5 |
| | | | | | | | 15 |

THREE PHASE - OBSOLETE 2011

| Shivvers Part # | Contactor # of Poles | Amp Rating | Max HP 230 VAC | Starter Part # |
|-----------------|----------------------|------------|----------------|----------------|
| 641E-001A | 3 | 60 | 15 | E-6291 |
| 641F-001A | 4 | 40 | 10 | E-6292 |

SINGLE PHASE- E6515 OBSOLETE 2020

| Shivvers OBS Part # | Contactor # of Poles | Amp Rating | Max HP 240 VAC | SHIVERS New Part # |
|---------------------|----------------------|------------|----------------|--------------------|
| 641C-001A | 2 OR 3 | 60 | 10 | 641Z-001A |
| 641D-001A | 4 | 40 | 5 | 641X-001A |

SINGLE & THREE PHASE

641X-001A

4 POLE, 40 AMP Contactor
10-40 AMP Overload

1. Contactor (E-6511)
2. Overload (E-6517)
3. Aux. Switch (if required) (E-6512)
4. Starter Harness Assy. (E-6293)
5. Electronic O.L. Bracket (641-077P)
6. DIN Rail, 3-3/8" Long (E-6522)

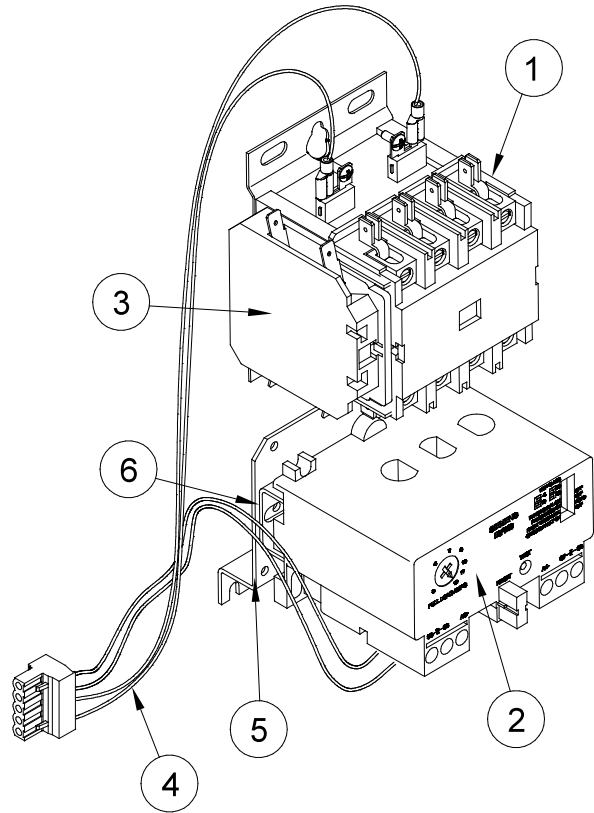

641Y-001A

4 POLE, 40 AMP Contactor
3-12 AMP Overload

1. Contactor (E-6511)
2. Overload (E-6516)
3. Aux. Switch (if required) (E-6512)
4. Starter Harness Assy. (E-6293)
5. Electronic O.L. Bracket (641-077P)
6. DIN Rail, 3-3/8" Long (E-6522)

641Z-001A

3 POLE, 60 AMP Contactor
25-100 AMP Overload

1. Contactor (E-6513)
2. Overload (E-6518)
3. Aux. Switch (if required) (E-6514)
4. Starter Harness Assy. (E-6293)
5. Electronic O.L. Bracket (641-077P)
6. DIN Rail, 3-3/8" Long (E-6522)

(in all kits)
P-12727 Decal

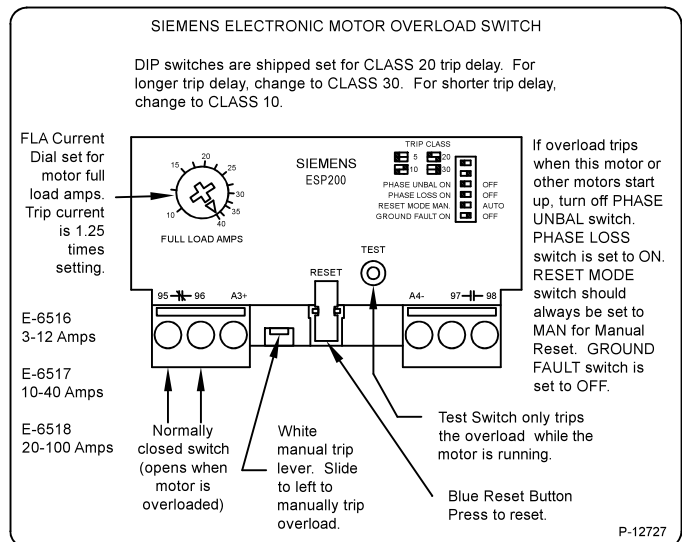

MACHINE MOTOR DISCONNECT SWITCH

(MECHANICAL INSTALLATION)

A Machine (Circu-Lator or Dri-Flo) Motor disconnect switch must be located adjacent to the bin entrance door. It must be of sufficient capacity to safely switch the Machine Motor, usually 10 or 15 Hp. This switch must also have the capability of being locked into the OFF position. Contact Shivvers Incorporated if assistance is needed to size the proper disconnect.

Make sure the safety decal P-12184 is applied on or near the machine motor disconnect. See the "Operator's Safety Manual", for complete instructions.

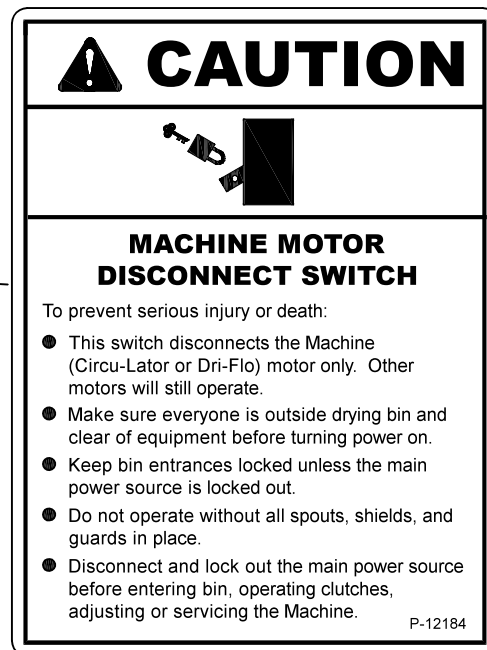
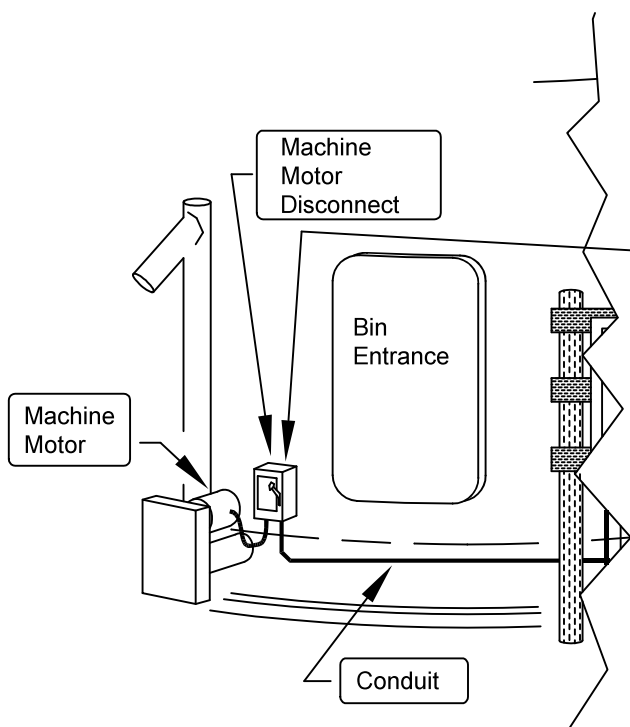

"CAUTION" Decal
Shivvers# P-12184

INSTALLING THE CONTACTOR AND OVERLOAD



DISCONNECT AND LOCK OUT POWER TO THE ENTIRE DRYING SYSTEM BEFORE OPENING THE MAIN COVER ON THE CONTROL BOX.

Before installing the contactor and overload, disconnect and lockout all power before opening the main cover. Test several points with a known good tester to verify power is disconnected. Find the mounting location on the starter panel for the parts you are installing. Make sure the contactor and overload are sized properly for the motor connected to it. Check the motor name plate for the full load amps and check it against the information on page 3 to see if the contactor and overload are sized correctly. Each location on the starter panel is marked with a decal.

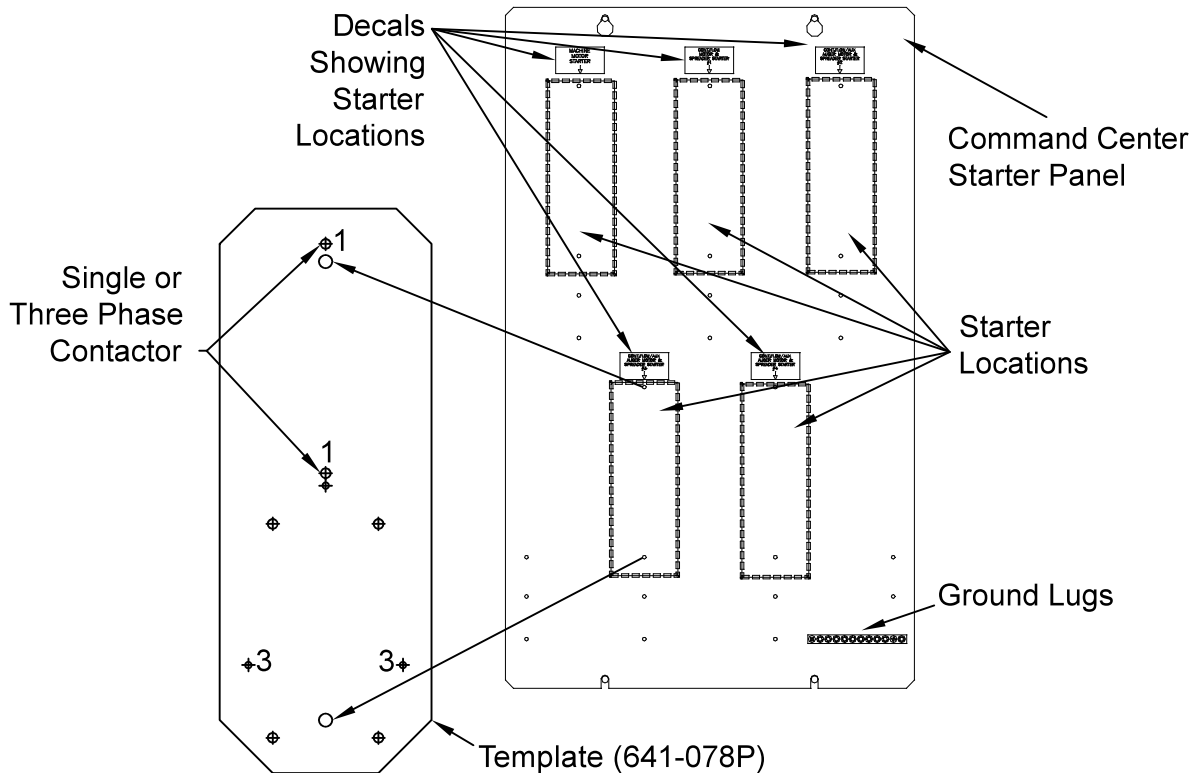

Older panels will require drilling of additional 9/64" diameter mounting holes. A template (641-078P) and drill bit (H-2706) are provided. Use two #8 x 3/8" screws to mount the template to the panel using the largest holes in the template and the original holes punched in the panel. Drill the holes labeled #1 on the template drawing to mount the contactor (single or three phase). The bottom original hole is usually sufficient for mounting the electronic overloads. However, as an option, or in panels which don't have enough depth, the holes labeled #3 on the template drawing can be drilled and used to mount the DIN rail (removed from the bracket) directly to the panel. This is usually only necessary for the 25-100 Amp Overload (E-6518).

INSTALLING THE CONTACTOR

To mount the contactor take 2 mounting screws supplied with the installation kit and start them in the mounting holes. The 60 Amp contactor takes two #8 X 1/2" screws. The 40 Amp contactor takes two #8 X 3/8" screws. Do not tighten the screws down, just get them started. At the top of the contactor bracket, in the center, there is a large hole with a slot at the top. The hole will allow the head of the screw to pass through. The bottom of the bracket has a slot to slide over the screw. Place the contactor over both mounting screws and slide it down. The heads of the screws should hold the contactor in place. Tighten the mounting screws to secure the contactor.

INSTALLING THE OVERLOAD

SINGLE & THREE PHASE

(Command Center)

For 3-12 Amp (E-6516), 10-40 Amp (E-6517), and 25-100 Amp (E-6518) Overloads
Position the overload and bracket so that the 3 motor wire holes on the overload are
in line with the left 3 terminals on the contactor.

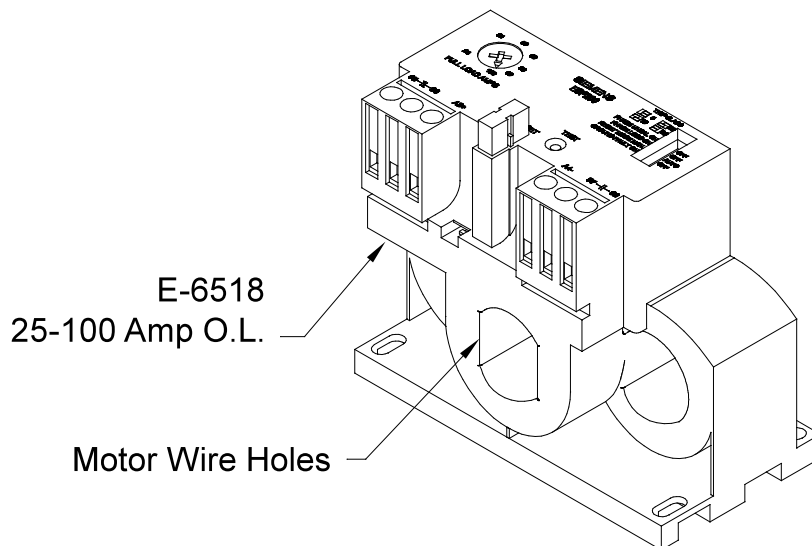
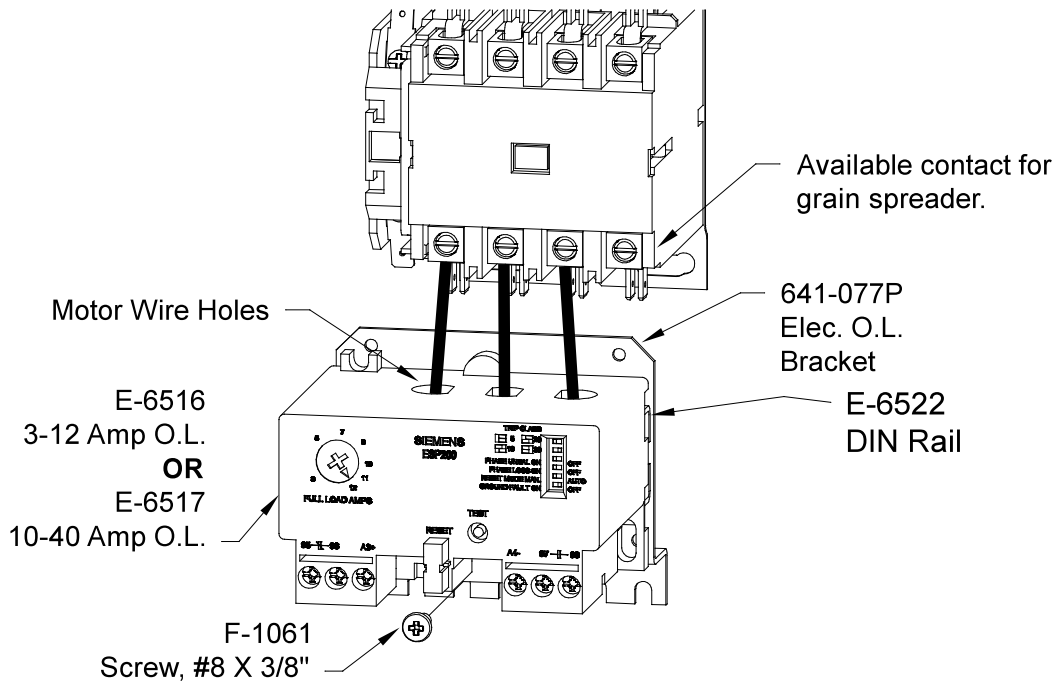

INSTALLING THE OVERLOAD

SINGLE & THREE PHASE

(Low Level, Or Aux. Auger Add-On Boxes)

For 3-12 Amp (E-6516) and 10-40 Amp (E-6517) Overloads

Position the overload and bracket so that the 3 Motor Wire Holes on the overload are in line with the right 3 terminals on the contactor.

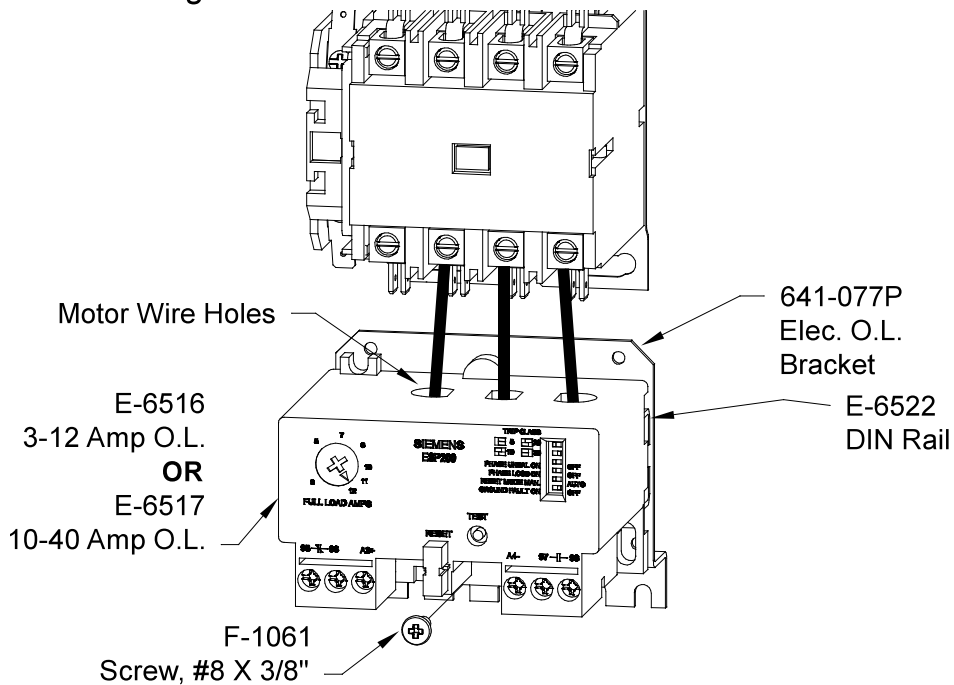

For 25-100 Amp (E-6518) Overload

Because the Low Level and Aux. Auger boxes aren't deep enough, remove the DIN rail from the bracket and mount the DIN rail (E-6522) directly to the panel using two #8 X 3/8" screws (F-1061). Install the Overload on the DIN rail. The overload has channels on the bottom that the DIN rail snaps on to.

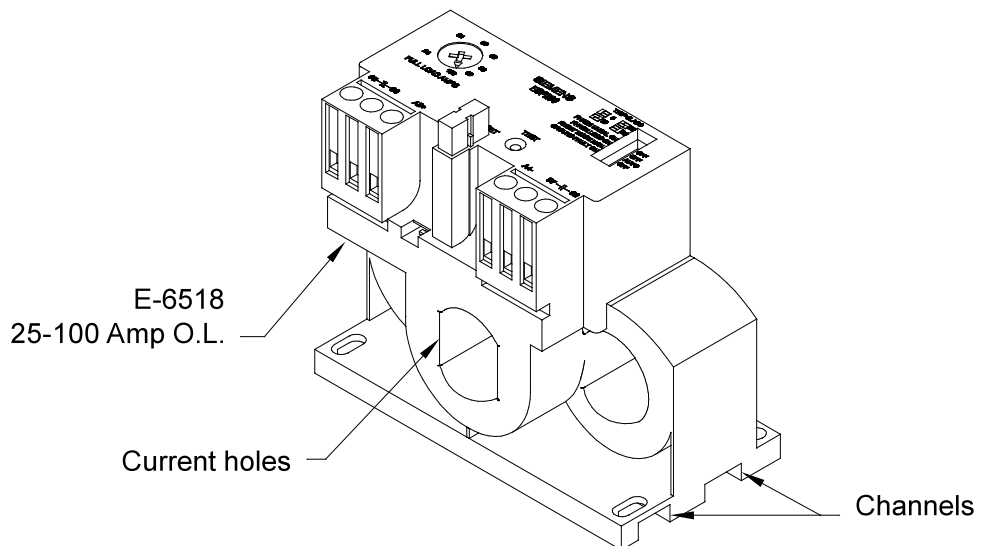

INSTALLING THE OVERLOAD

SINGLE & THREE PHASE

The contactor and overload are shipped in 2 separate pieces. The left connector on the overload is removed after testing but is still connected to the wire harness. During installation the connector will need to be re-installed. See illustration below.

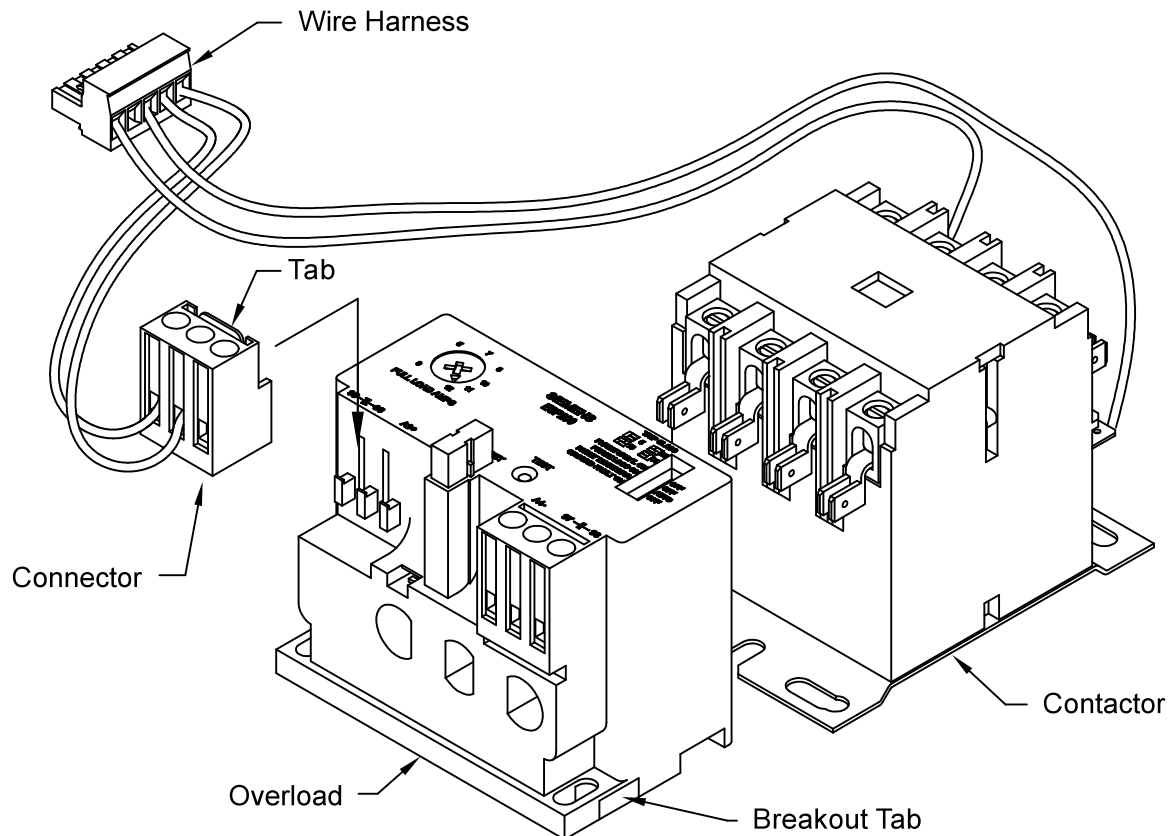

To attach, slide the connector down until it snaps into place. To disconnect, pull the tab forward while pushing the connector straight up. The left and the right connectors are not interchangeable.

If more adjustment is needed to center up the overload to the contactor, a breakout tab on each side can be cut out to allow the overload to slide along the DIN rail from side to side.

WIRING THE STARTER

Connect the starter wiring harness to the switch/relay panel by locating the 5 pole connector on the relay panel that corresponds to the starter being installed. Each 5 pole connector is labeled with the starter it controls. The machine connector is located underneath the switch plate and can be accessed from the side. (See below.) High torque units have two machine starters. A "y" adapter is provided for making the starter connections, in Command Centers only. Premier, Convert, and TS panels have terminal strips for two machine starters.

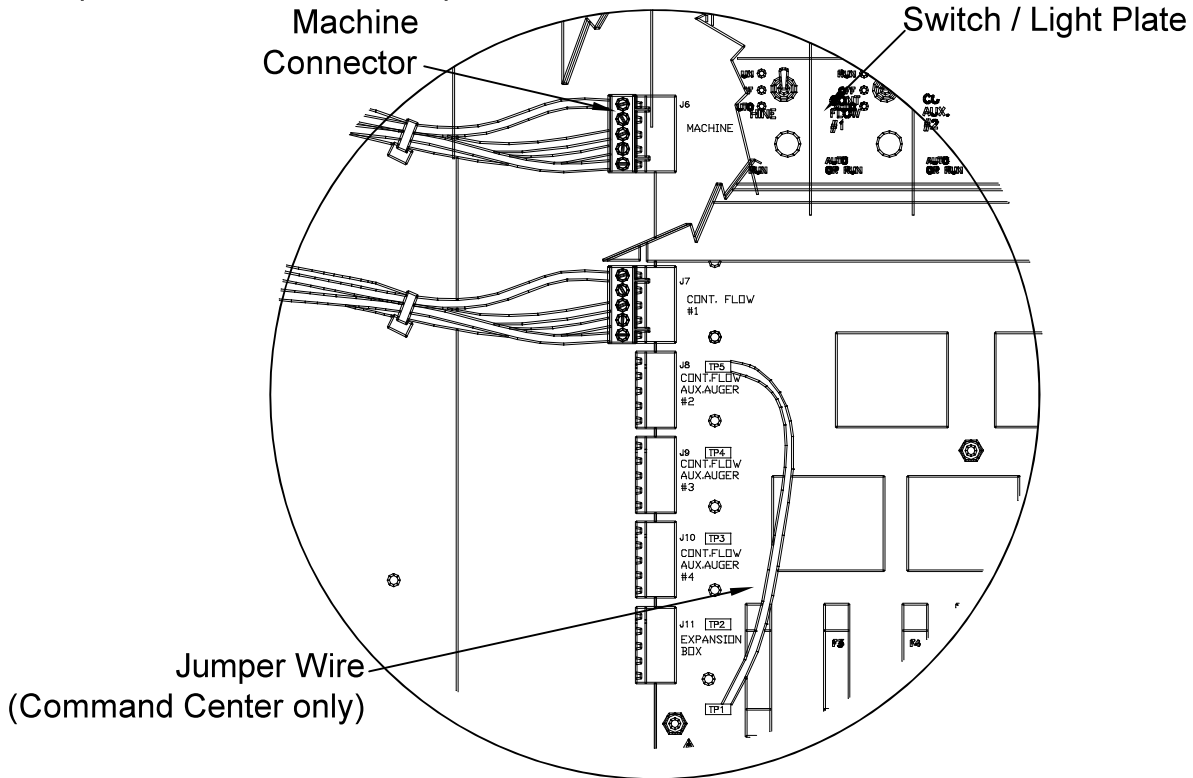

For Command Centers only, when installing continuous flow or Auxiliary auger starters, a jumper must be connected across the unused slots on the relay board. The jumper is connected to spade terminal TP1 then to the terminal below and to the right of the last used slot. See chart below for jumper configurations.

| LAST AUGER IS | JUMPER | TO |
|-------------------|---------------|-----|
| CONT. FLOW #1 | TP1 | TP5 |
| CONT. FLOW/AUX #2 | TP1 | TP4 |
| CONT. FLOW/AUX #3 | TP1 | TP3 |
| CONT. FLOW/AUX #4 | TP1 | TP2 |
| EXPANSION BOX | REMOVE JUMPER | |

WIRING THE STARTER, cont'd

Run power wires and a good ground from the breaker panel through conduit to the Command Center control box. Enter through the left hand side of the Command Center bottom, directly below the starter locations. For single phase applications, 6 gauge wire is recommended for the machine motor and 8 gauge wire for Cont. Flow motors, unless the motor is 7.5 to 10 HP, then use 6 gauge wire, to cover expansion capabilities. For 3 phase applications, check motor amperage at available voltage for wire sizing. Route the wires in the control box so they will terminate at the top of the starter. Next run wires from the bottom side of the starter and/or overload relay(s) to the Motor Safety Disconnect Switch. Then run wires from the Disconnect Switch to the motor. The wires should be in conduit and have a separate ground wire for each motor circuit. The ground wire will terminate at the ground lugs at the bottom right hand corner of the starter panel. The wiring for the spreader motor (if applicable) should be run at the same time. The Cont. Flow starters have an extra contact (both single and three phase) that can be used to run the spreader motor. The spreader motor(s) will need to also have a separate breaker. Page 15 has a diagram showing the completed motor wiring.

WIRING THE STARTER, cont'd

THREE PHASE

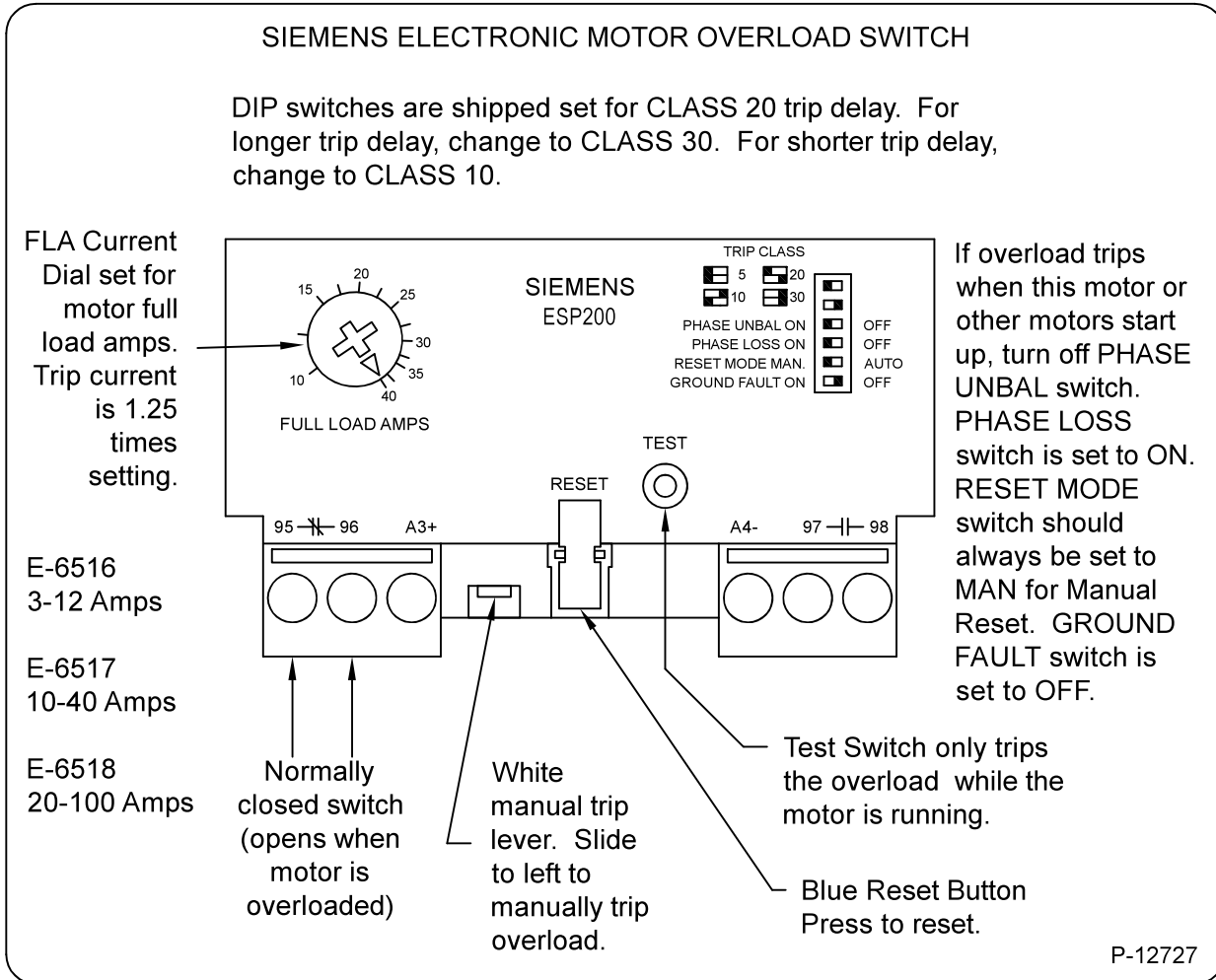

Set the Full Load Amps dial to the motor nameplate full load amps. The trip current is 1.25 times the dial setting.

Place decal P-12727 on panel, or panel cover.

To remove the overload from the DIN rails, push down on the overload and pull the bottom of the overload out of the rail first.

WIRING THE STARTER, cont'd

USING 3 POLE ELECTRONIC OVERLOAD FOR 1 PHASE

120 / 240 Volt, Single Phase

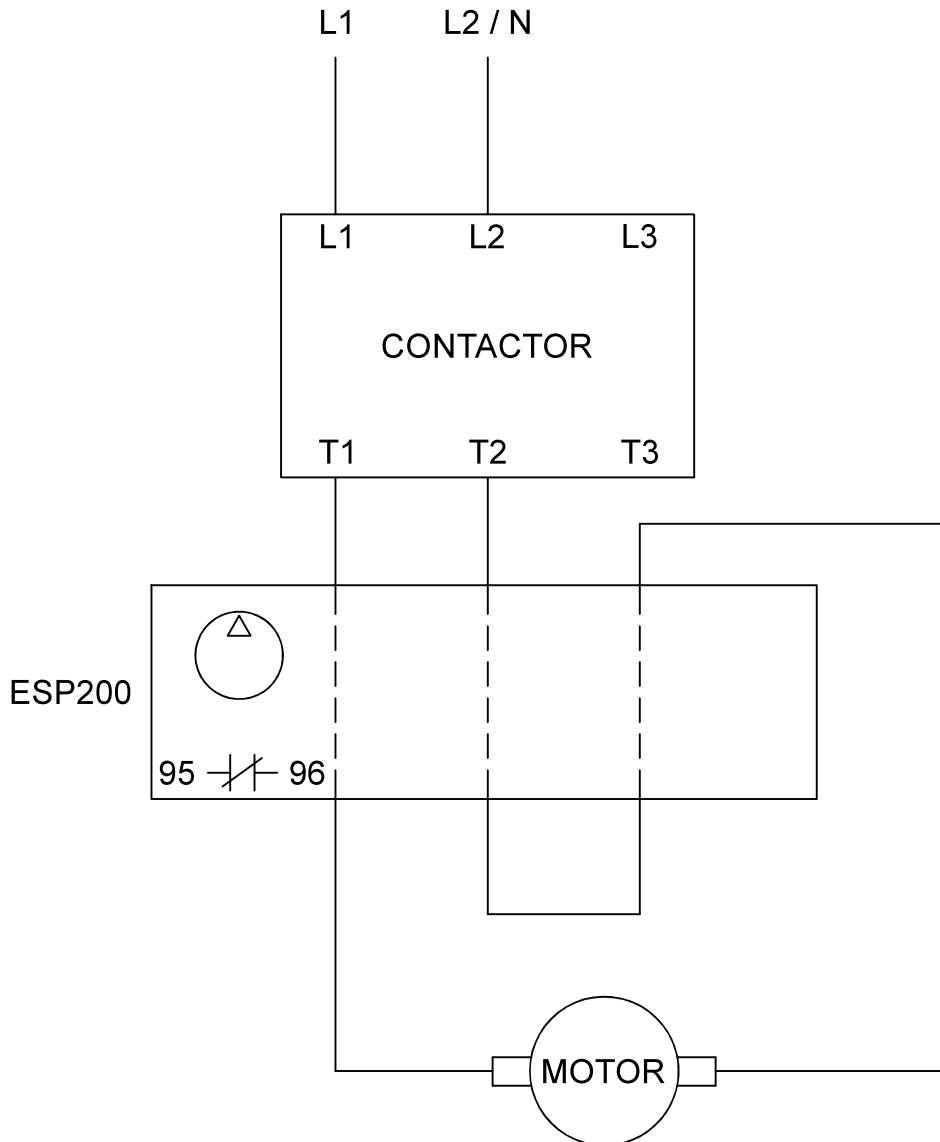

1. Motor wires must be routed as shown above.
2. Because most single phase motors have a 1.0 service factor, set Full Load Amps (FLA) at motor nameplate FLA times 0.80.
For example, if 1 phase motor FLA = 40, set overload dial at $40 \times 0.80 = 32$ Amps. Trip Amps is now $32 \times 1.25 = 40$ amps
3. Turn OFF the PHASE UNBAL and PHASE LOSS switches on the overload.

MOTOR WIRING

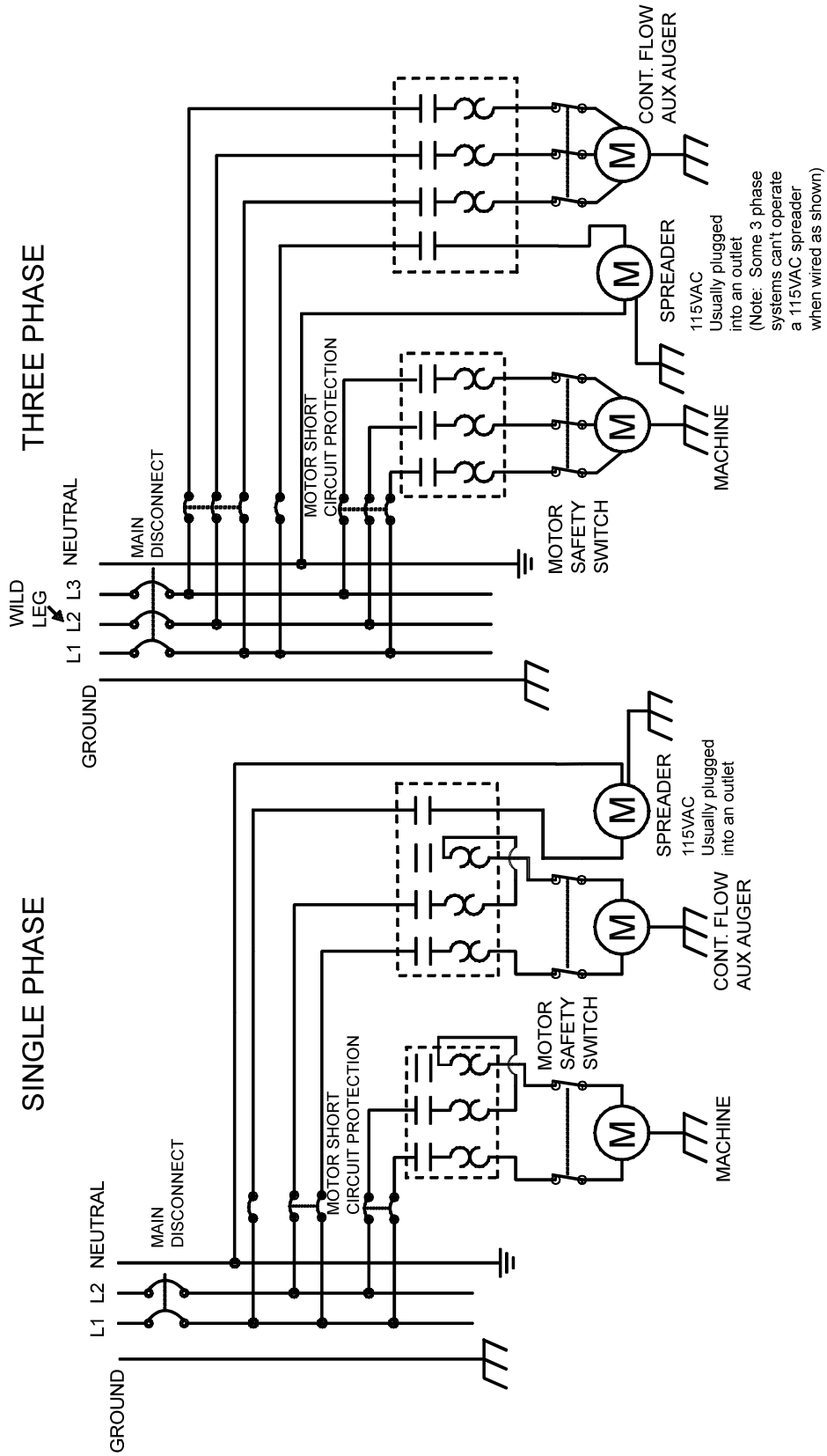

RECORD MOTOR INFORMATION

Use a permanent marker and fill out the decal inside the Command Center front cover, shown below, for each starter installed. The Premier and TS panels have a similar decal.

| | | | | |
|---|--|-----------------------------------|----------|--------------------------------|
| MODEL 641A-001A | | | | |
| MAX MOTOR VOLTAGE 600VAC, MAX HP DETERMINED BY STARTER SIZE | | | | |
| ACTUAL MOTOR VOLTAGE _____ | | | | |
| PHASE 1 OR 3 _____ | | | | |
| | | MACHINE MOTOR HP _____ | FLA_____ | 120VAC SPREADERS |
| | | CONT. FLOW #1 HP _____ | FLA_____ | # 1 SPREADER HP _____ FLA_____ |
| MOISTURE CONTROL BOARD CONFIGURATION <input type="checkbox"/> CENTER <input type="checkbox"/> VERTICAL <input type="checkbox"/> BOTTOM <input type="checkbox"/> UNLOAD | | CONT. FLOW/AUX. AUGER #2 HP _____ | FLA_____ | # 2 SPREADER HP _____ FLA_____ |
| | | CONT. FLOW/AUX. AUGER #3 HP _____ | FLA_____ | # 3 SPREADER HP _____ FLA_____ |
| | | CONT. FLOW/AUX. AUGER #4 HP _____ | FLA_____ | # 4 SPREADER HP _____ FLA_____ |

STARTER SCHEMATIC

